

# WRD14 / WRD16

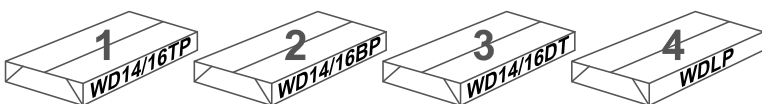

**TOOLS REQUIRED  
FOR ASSEMBLY**

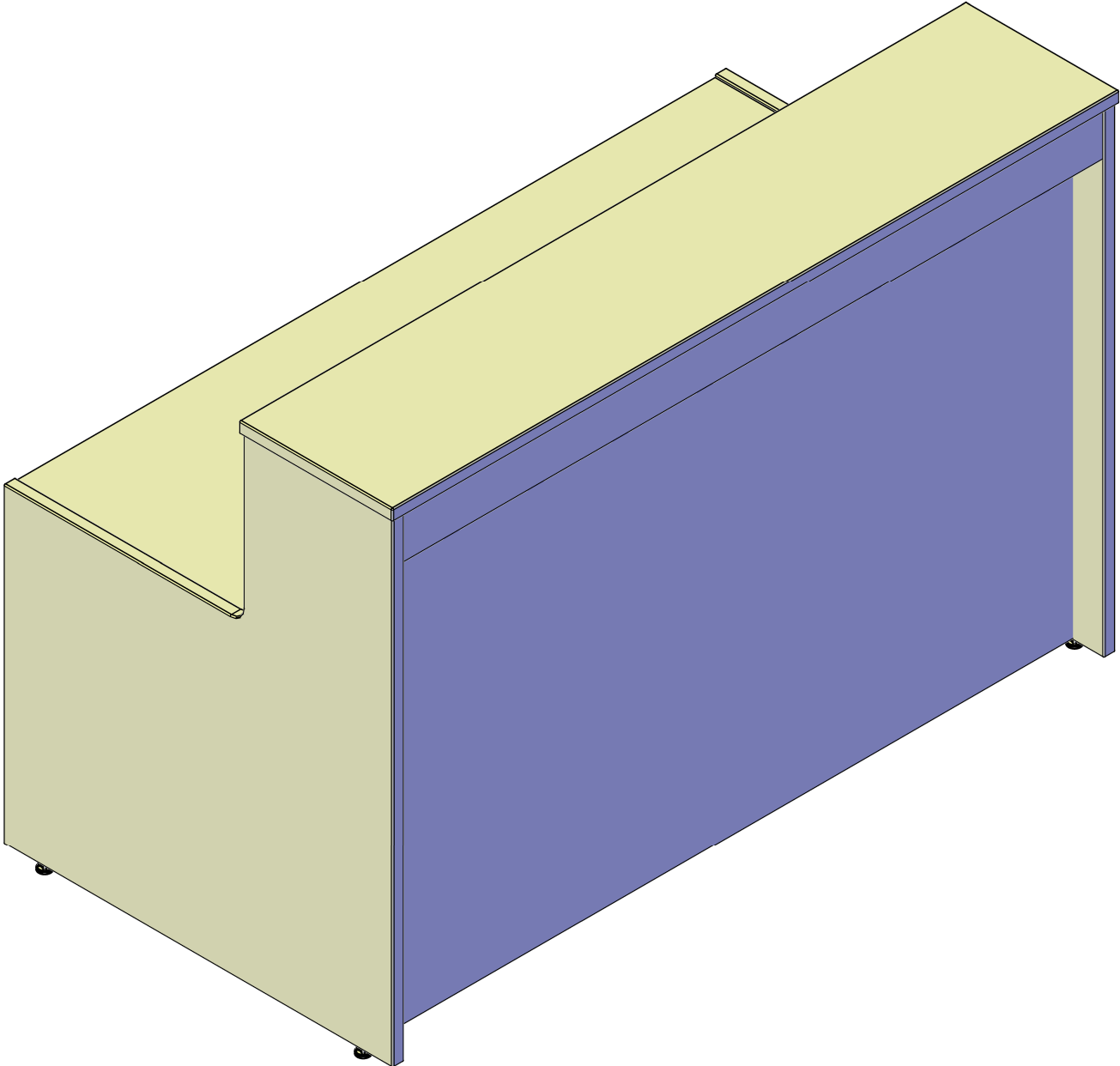
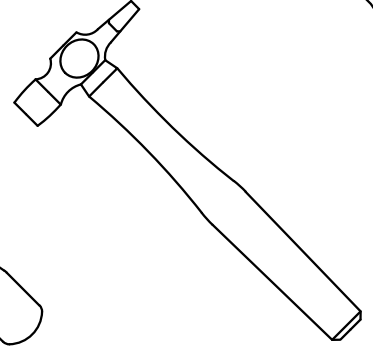
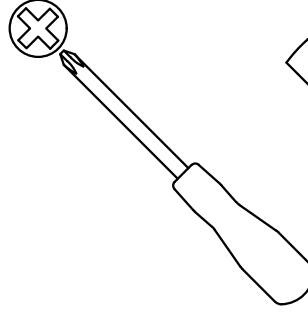
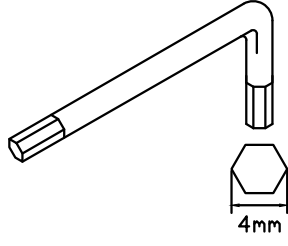

**DONT STRUGGLE  
2 MAN LIFT**

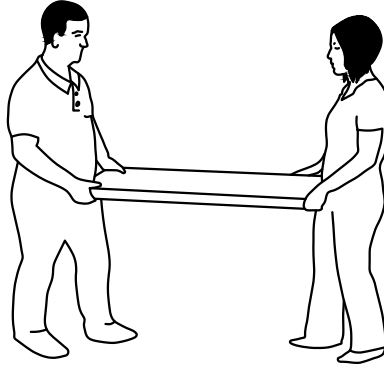
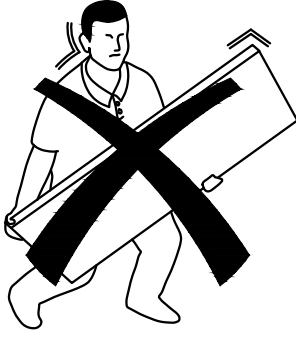

**ALWAYS HANDLE  
ITEMS WITH CARE**

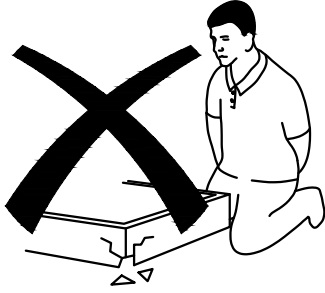

**IF UNSURE CALL  
FOR ASSISTANCE**

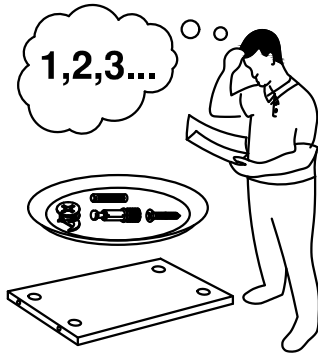

**KEEP FITTINGS AWAY  
FROM CHILDREN**

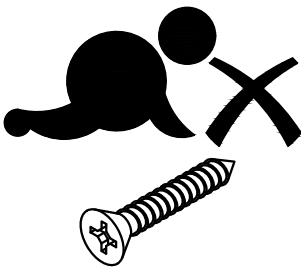





Please check that you have all the fittings!

2 x Fittings Bags Supplied  
1 in Carton 3 - WD14/16DT  
1 in Carton 4 - WDLP

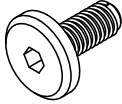
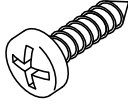
**Fitting Bag**  
**1**  
RM-FIT254

<b>21</b>	M6x16mm Connect Bolt RM-SY0622 	<b>4</b>	3/4 x 14mm Screw RM-SCR04 	<b>10</b>	M8 Gesipa Insert RM-PAR03 
-----------	------------------------------------------------------------------------------------------------------------------------	----------	--------------------------------------------------------------------------------------------------------------------	-----------	---------------------------------------------------------------------------------------------------------------------

**Fitting Bag**  
**2**  
RM-FIT240

<b>21</b>	15mm Cam RM-CAM03 	<b>21</b>	34mm Minifix Bolt RM-BLT07 	<b>4</b>	M8 Gesipa Insert RM-NUT04 
<b>21</b>	M6 Nylon Insert RM-PAR05 	<b>15</b>	17mm Adhesive Cover Cap RM-CAP07 	<b>4</b>	25mm Adjustable Foot RM-FRL19 

If you are assembling this unit with a D-End extension table please refer to the WDET assembly instruction before proceeding with step 1

**DAMS**  
Your Office Furniture Wholesaler

**WDET**  
Welcome Extension D-End

01.12.2015

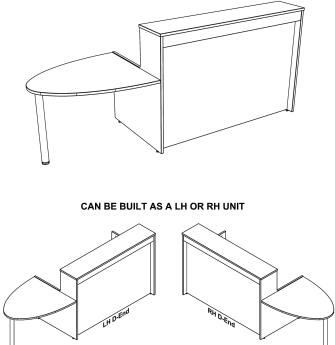

CAN BE BUILT AS A LH OR RH UNIT

1

**TOOLS REQUIRED FOR ASSEMBLY**

**DO NOT ATTEMPT TO ASSEMBLE**

**ALWAYS HANDLE PANELS WITH CARE**

**NEVER USE SAILS FOR ASSISTANCE**

**KEEP FITTINGS AWAY FROM CHILDREN**



Please check that you have all the fittings! (Fittings Bags Supplied in Both Cartons)

<b>Fitting Bag 1</b> RM-FIT241	3 M6 x 16mm Connect Bolt (RM-SY0622)	3 M6 x 16mm Connect Bolt (RM-SY0622)
	6 M6 Nylon Insert (RM-PAR05)	1 M6 x 16mm Connect Bolt (RM-SY0622)
	3 M6 x 16mm Nut (RM-NUT04)	

<b>Fitting Bag 2</b>	1 M8 Minifix Bolt (RM-BLT07)	1 M8 Gesipa Insert (RM-NUT04)
	5 3/4 x 14mm Screw (RM-SCR04)	

This instruction shows the assembly of a LH desk extension.

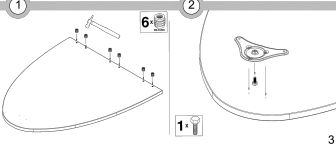
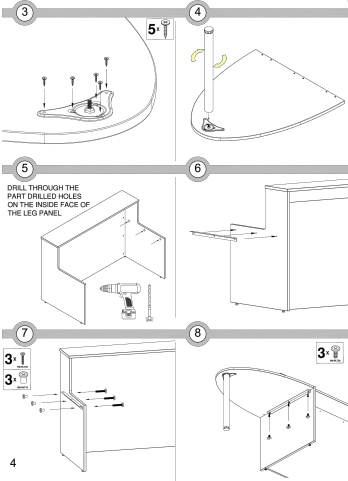



3, 4, 5, 6, 7, 8

DRILL THROUGH THE PART DRILLED HOLES ON THE INSIDE FACE OF THE LEG PANEL

Prepare the panels by inserting the listed fittings into the corresponding holes.

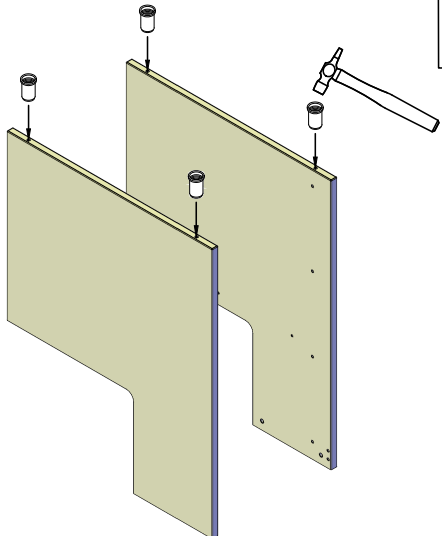
1



4x RM-NUT04

2

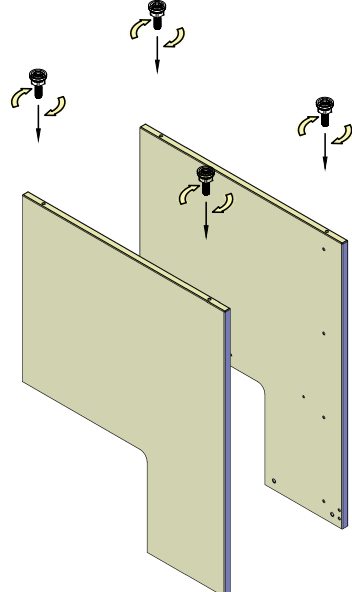

4x RM-FRL19

Prepare the panels by inserting the listed fittings into the corresponding holes.

3

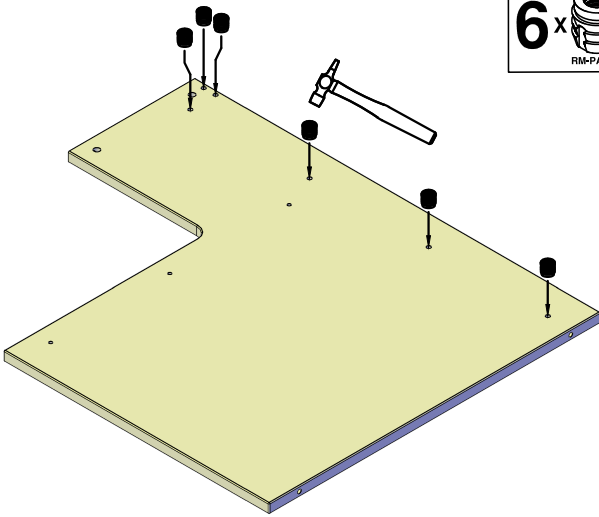

6x  
RM-PAR05

4

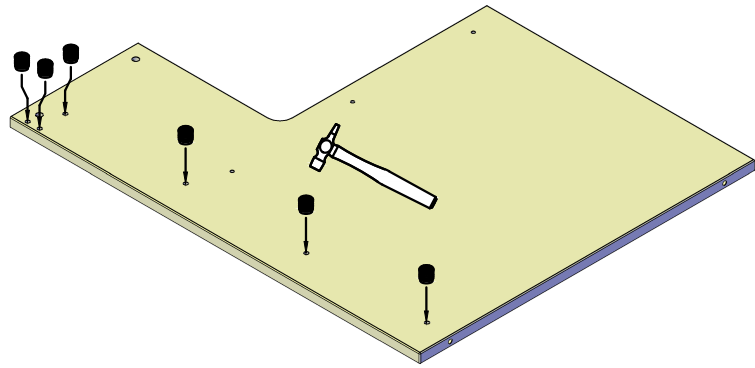

6x  
RM-PAR05

5

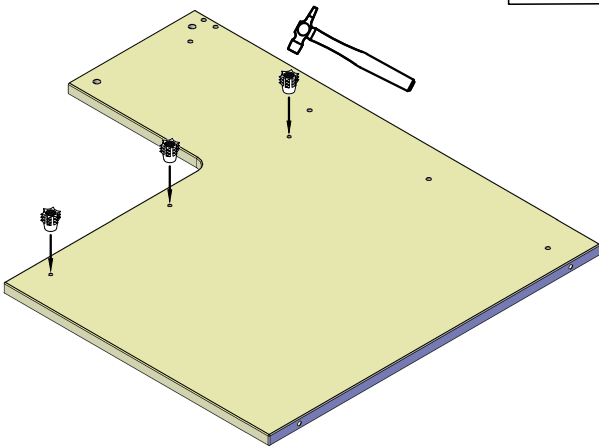

3x  
RM-PAR03

6

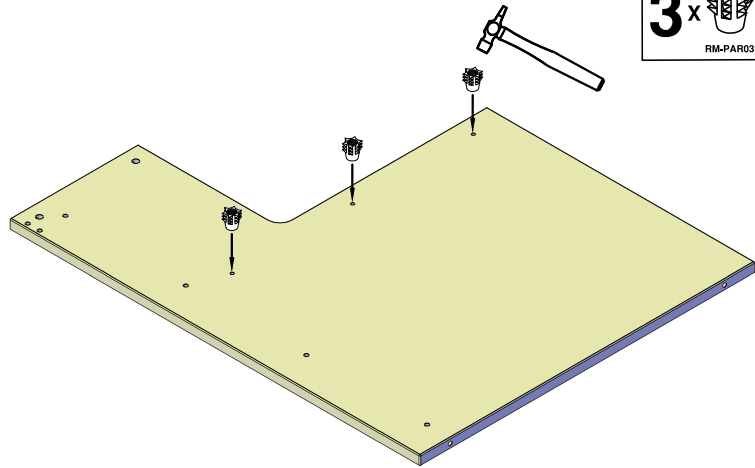

3x  
RM-PAR03

7

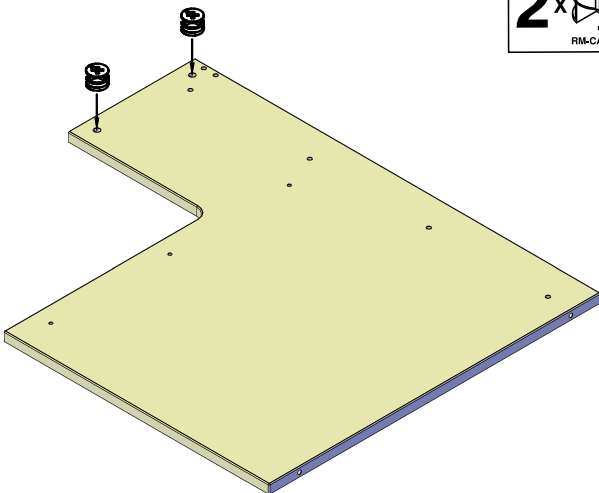

2x  
RM-CAM03

8

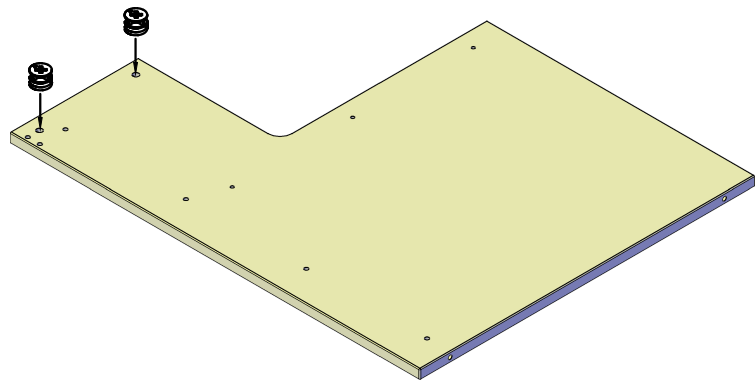

2x  
RM-CAM03

9

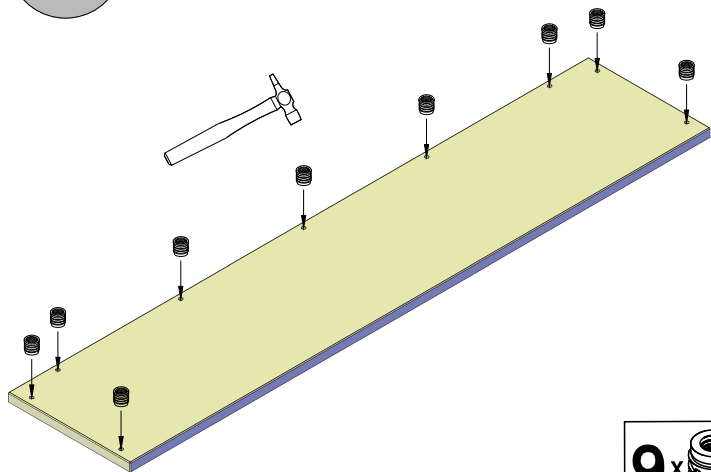

10

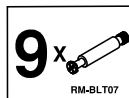
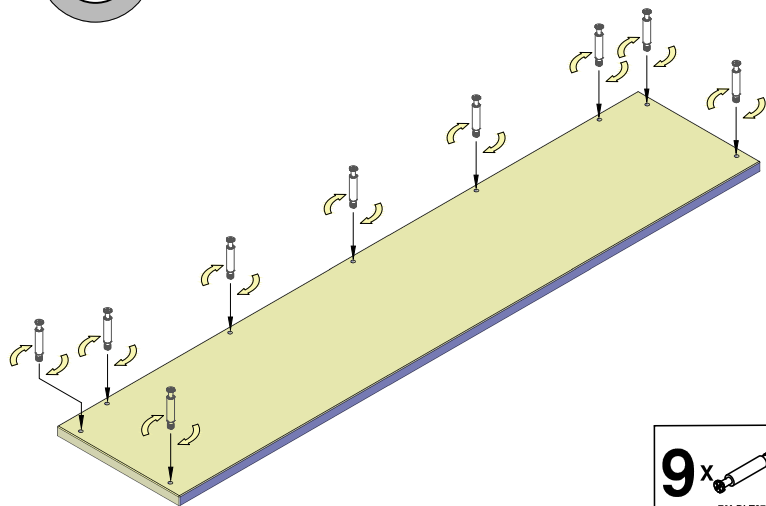

11

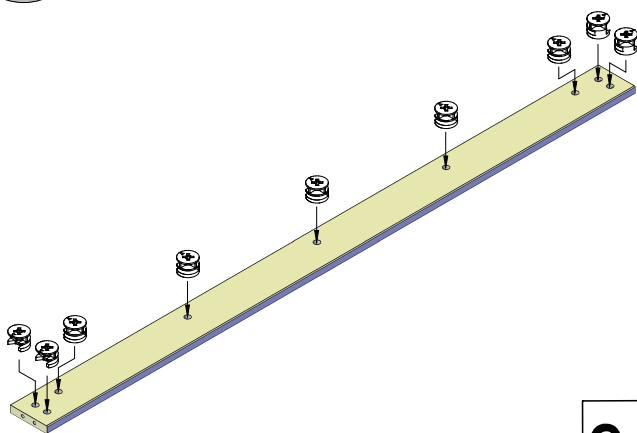

12

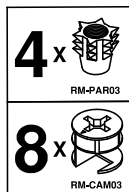
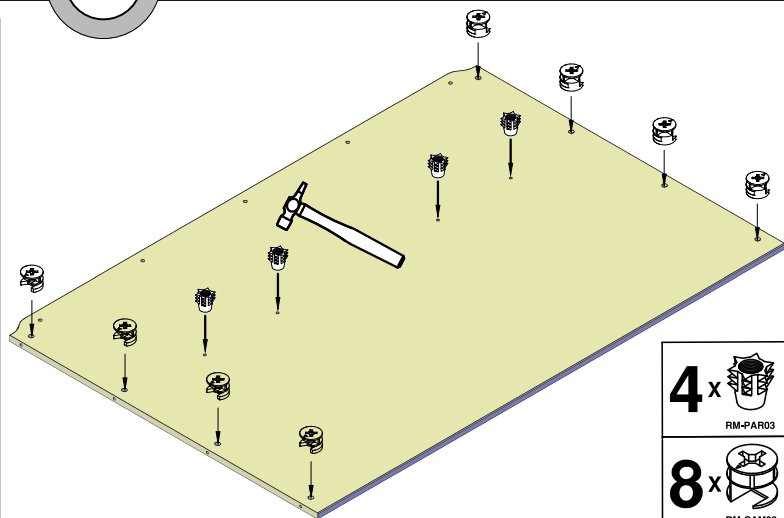

13

Join the panels together and tighten all cam fittings

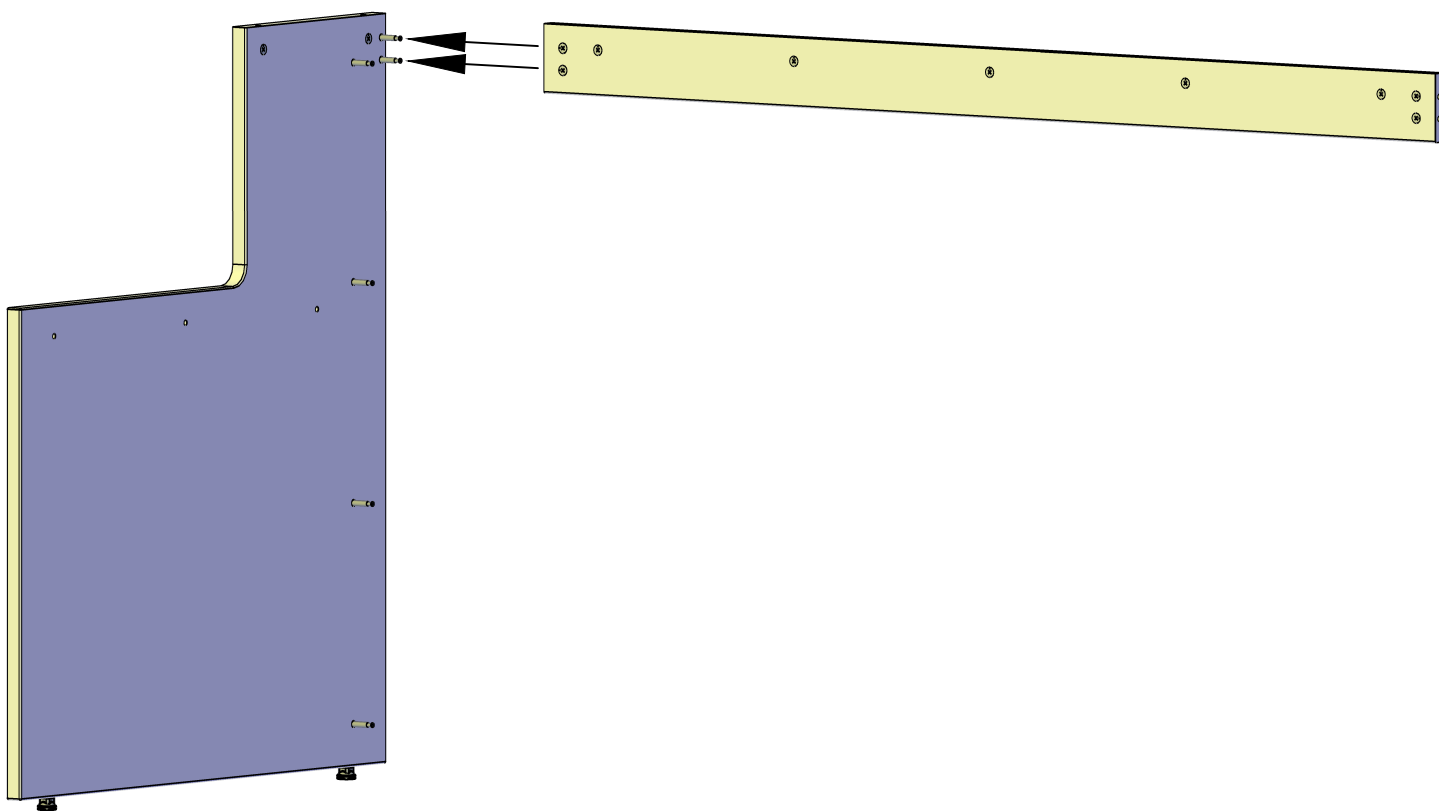

12

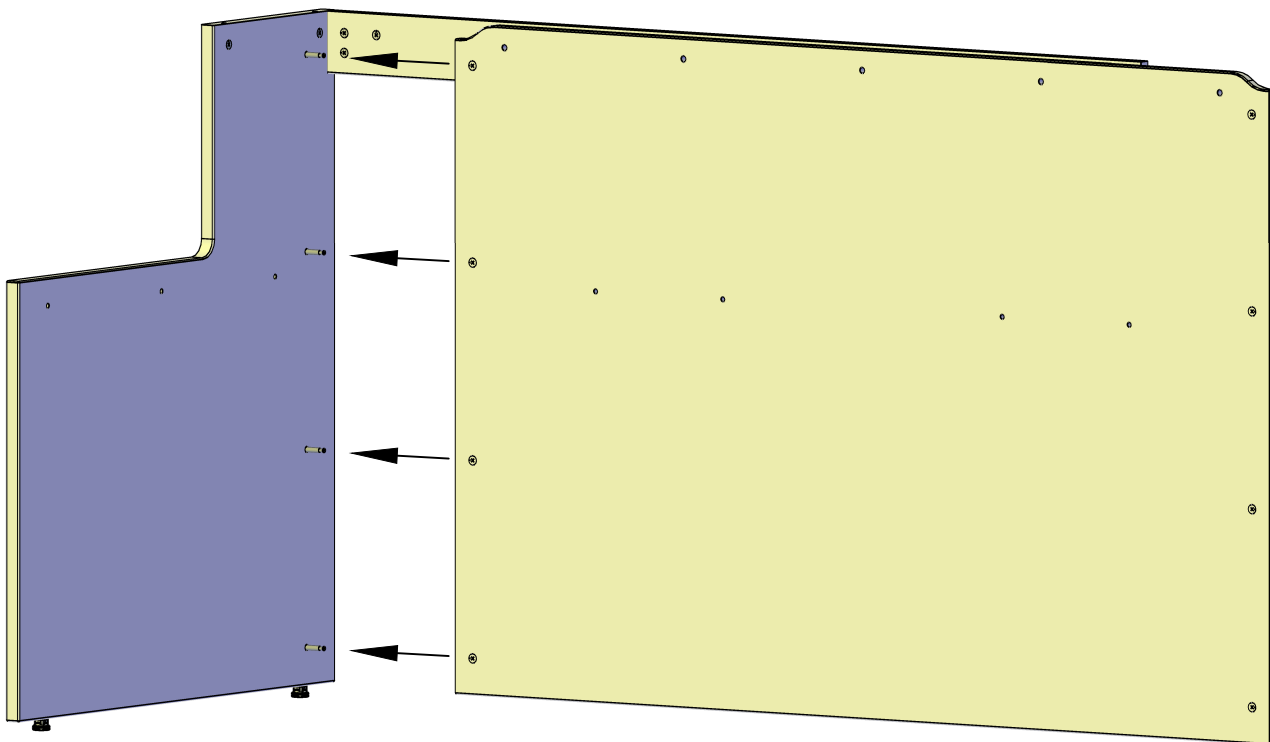

13

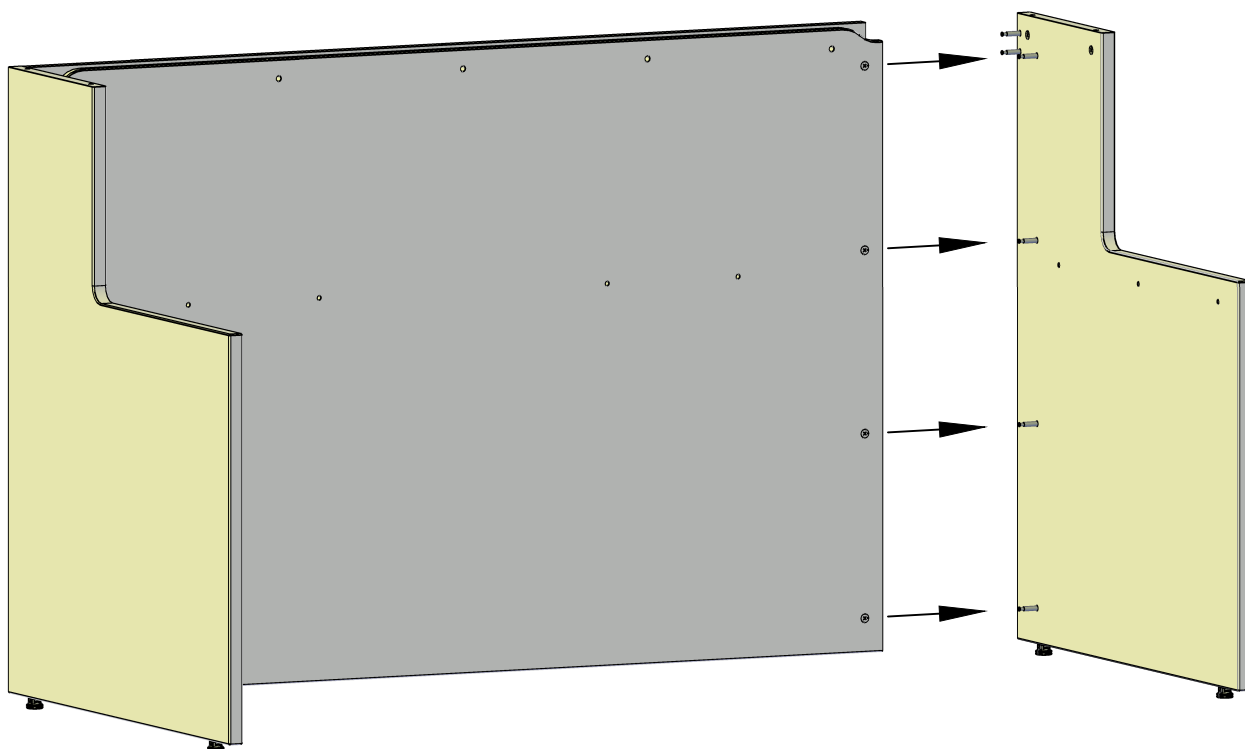

14

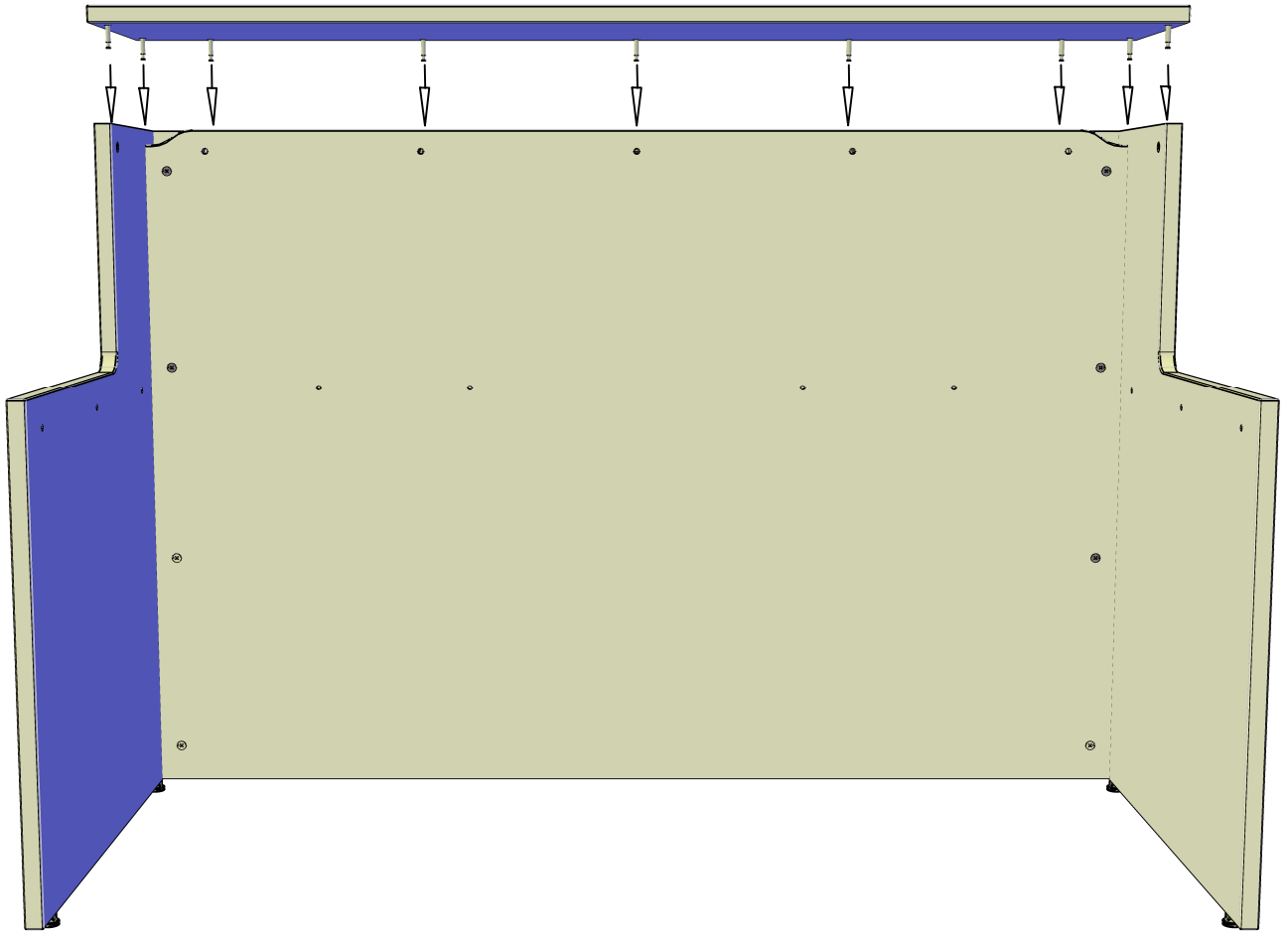

15

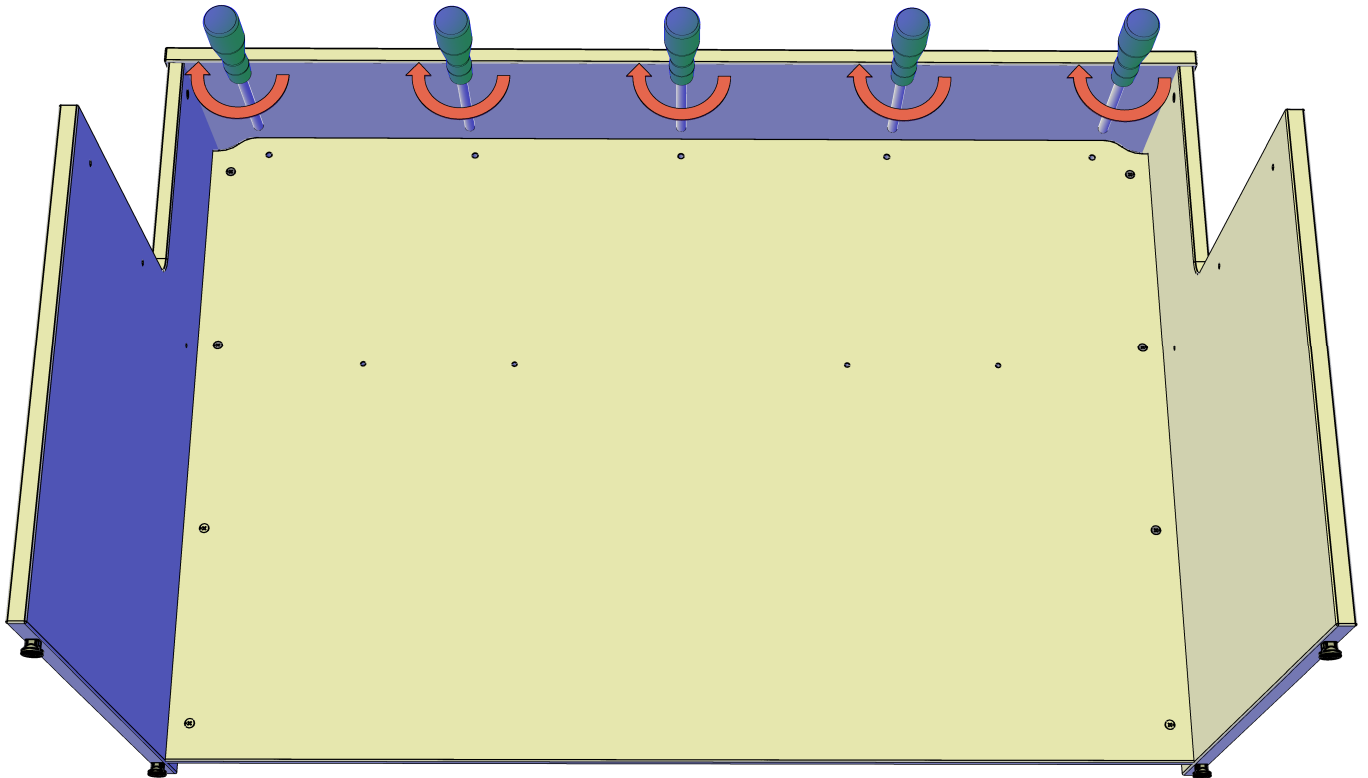

# If you are assembling this unit with a D-End extension table please refer to the WDET assembly instruction before proceeding with step 16

**DAMS**  
Your Office Furniture Wholesaler

**WDET**  
Welcome Extension D-End

CAN BE BUILT AS A LH OR RH UNIT

1

**TOOLS REQUIRED FOR ASSEMBLY**

**DONT STRUGGLE 2 MAN LIFT**

**ALWAYS HANDLE ITEMS WITH CARE**

**BE SURE CALL FOR ASSISTANCE 1,2,3...**

**KEEP FITTINGS AWAY FROM CHILDREN**

Recycling symbol

Please check that you have all the fittings! (Fittings Bags Supplied in Each Carton)

<b>Fitting Bag 1</b> RM-FT241	3 M6 x 12mm Corner Bolt M6-12-30	3 M6 x 12mm Corner Bolt M6-12-30
	6 M6 Nylon Locknut M6-12-30	1 M6 x 12mm Corner Bolt M6-12-30
<b>Fitting Bag 2</b>	1 M6 Flange Bolt	1 M6 x 12mm Corner Bolt M6-12-30
	5 Screw Panel Spacer	

This instruction shows the assembly of a LH desk extension.

DRILL THROUGH THE PART DRILLED HOLES ON THE INSIDE FACE OF THE LEG PANEL

16

6x  
RM-SY0622

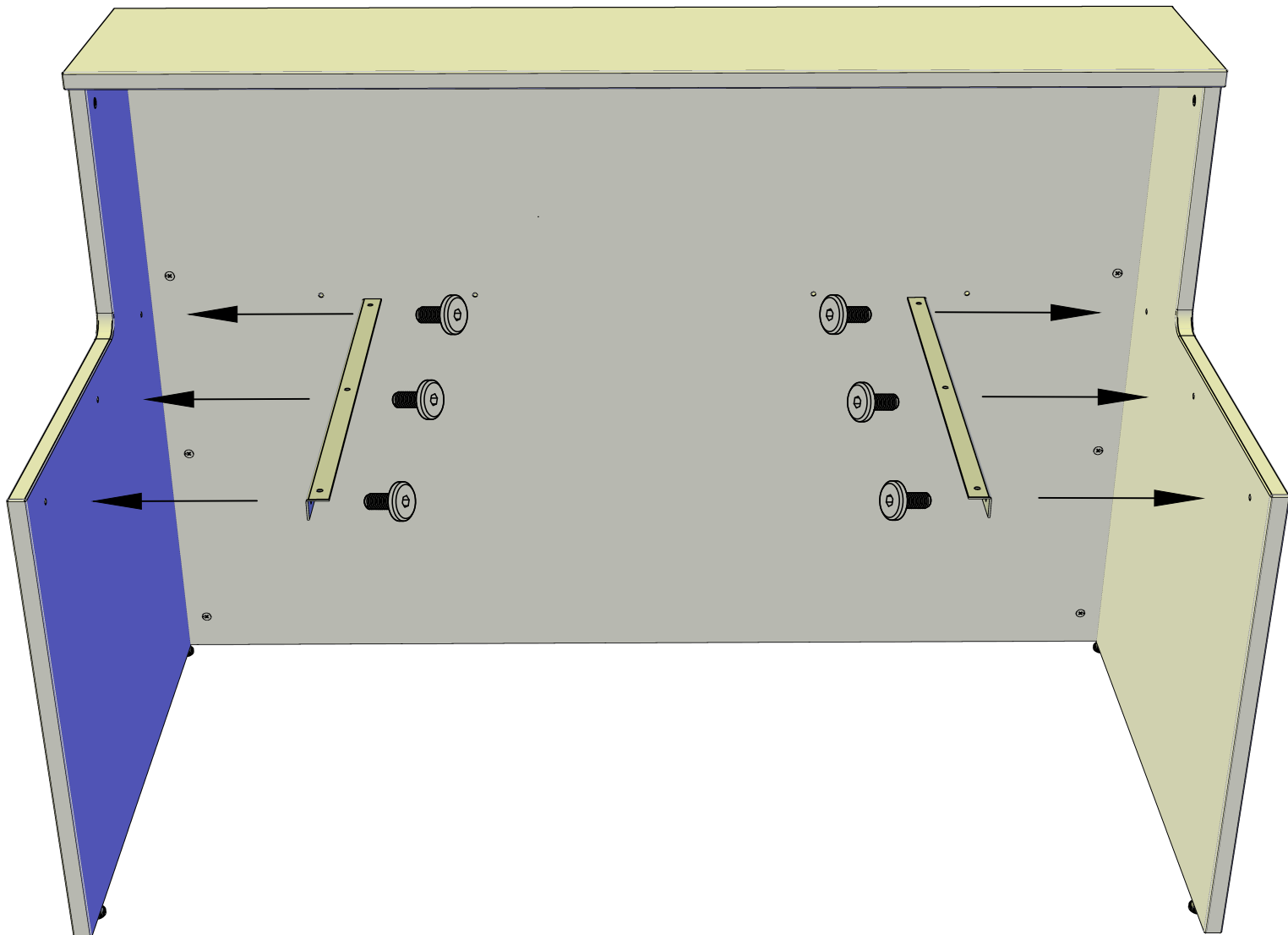



17

4x  
RM-SY0622

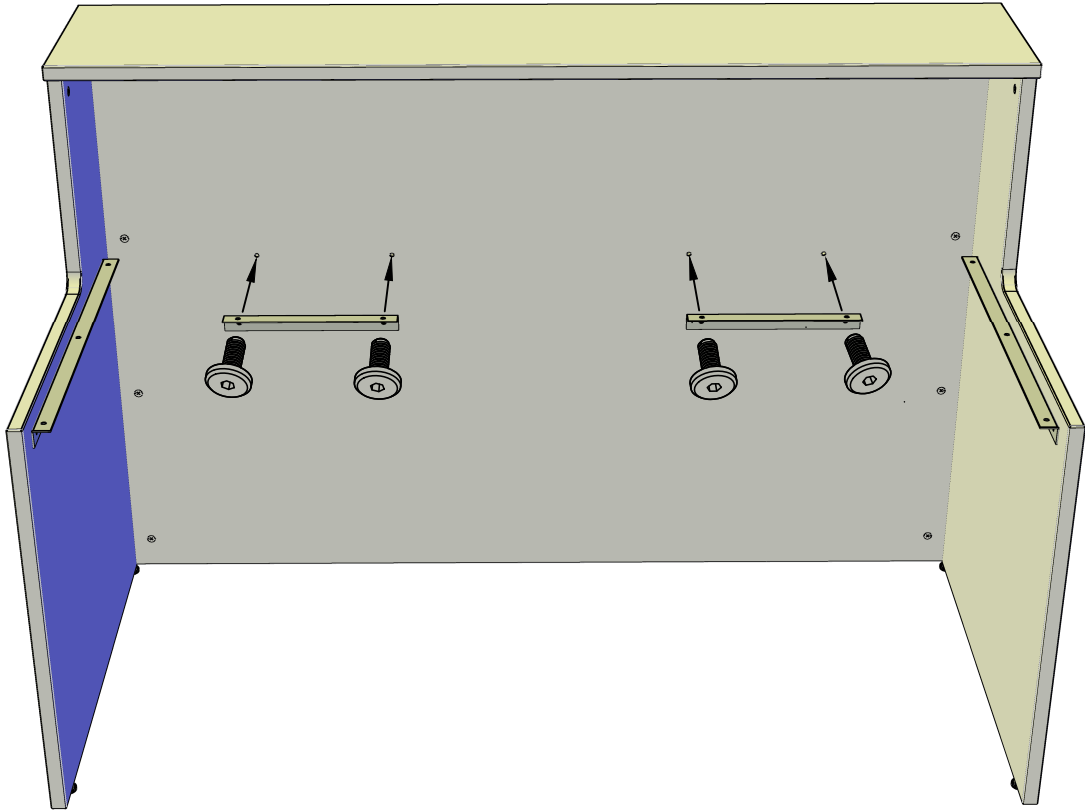

18

