

# FZ1600OL Fuze Outer Leg

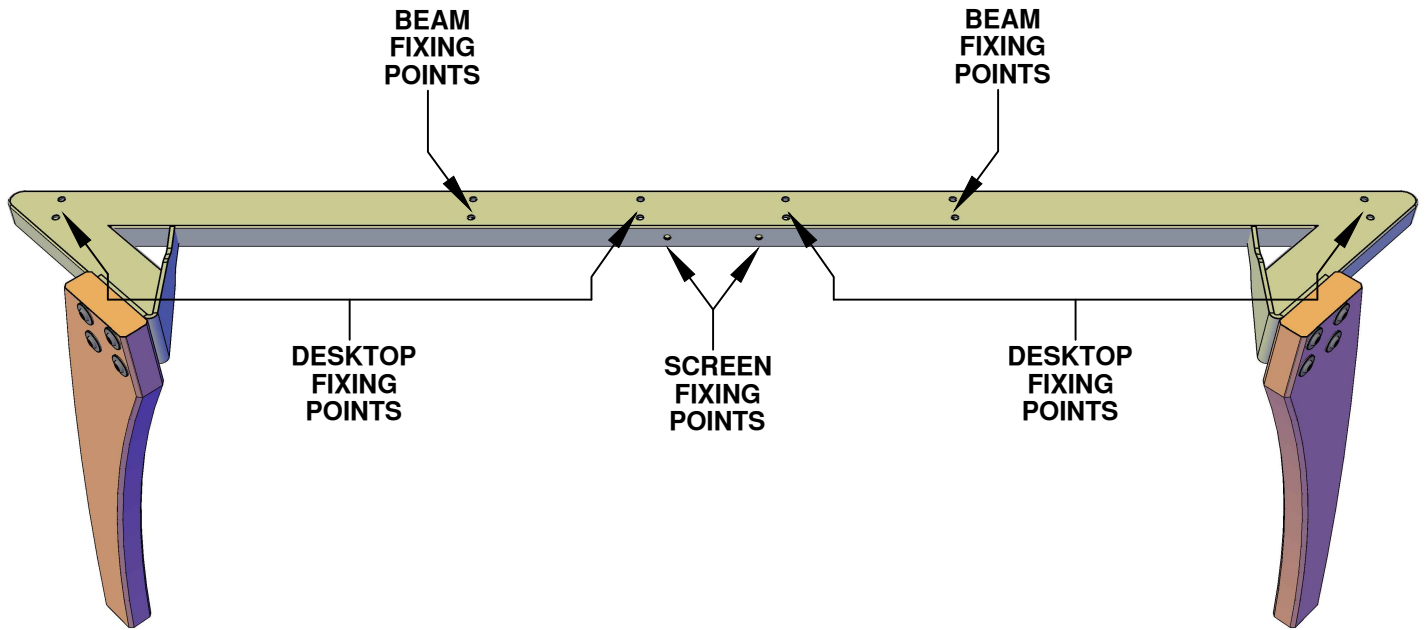

Used to build

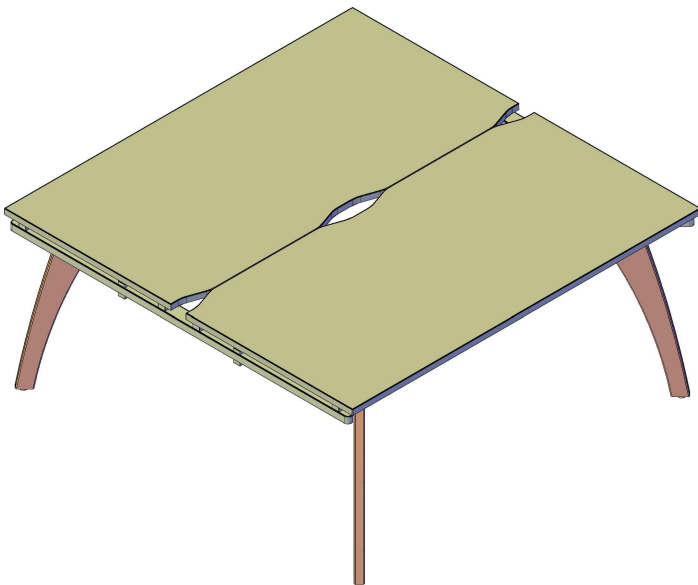

**Fuze Back to Back Desk**

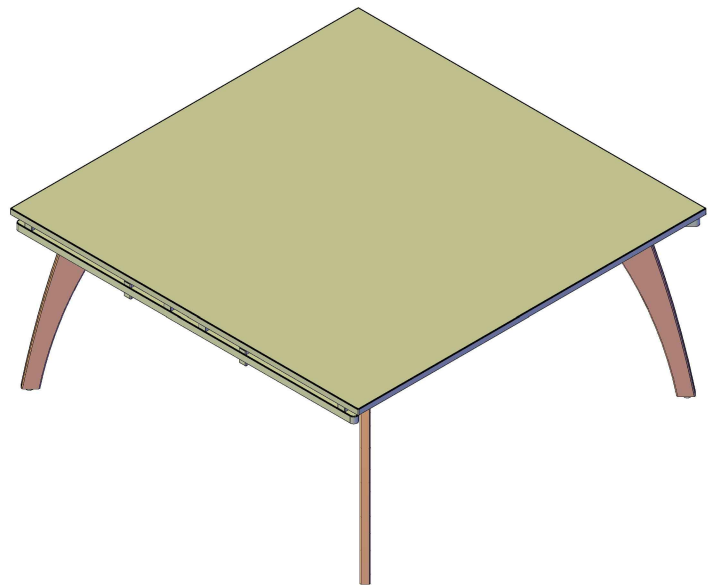

**Fuze Boardroom Table**

**TOOLS REQUIRED  
FOR ASSEMBLY**

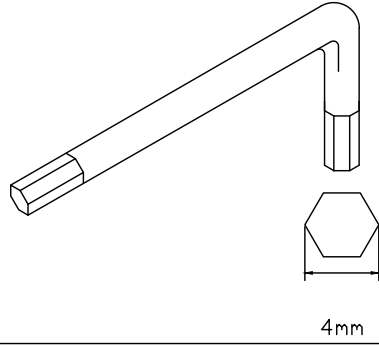
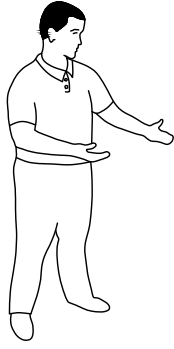

4mm

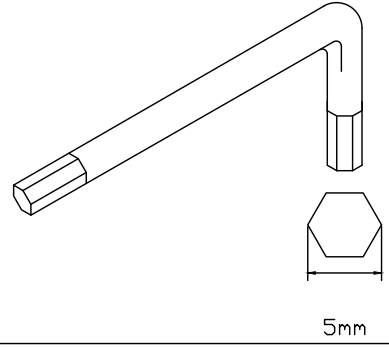

5mm

**DONT STRUGGLE  
2 MAN LIFT**

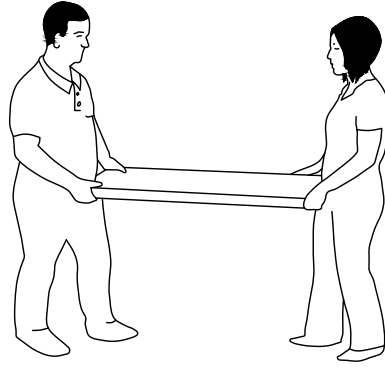
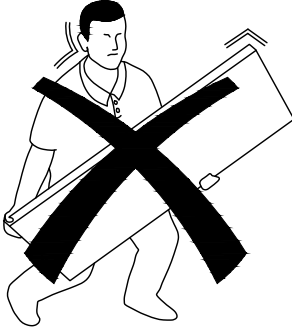

**ALWAYS HANDLE  
ITEMS WITH CARE**

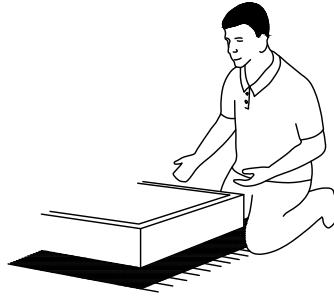
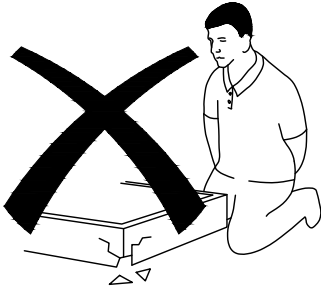

**IF UNSURE CALL  
FOR ASSISTANCE**

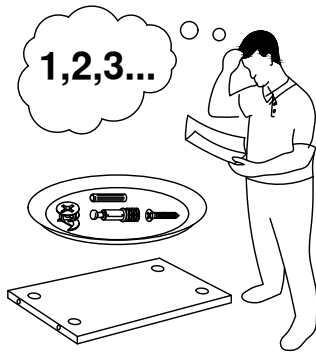

**KEEP FITTINGS AWAY  
FROM CHILDREN**

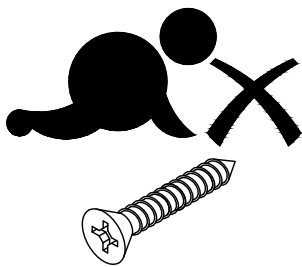



# Please check that you have all the components

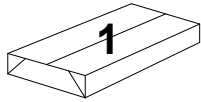

**2 x DESK TOP**

800mm Deep Tops

1200mm = ED128T  
1400mm = ED148T  
1600mm = ED168T

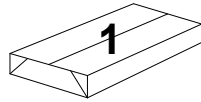
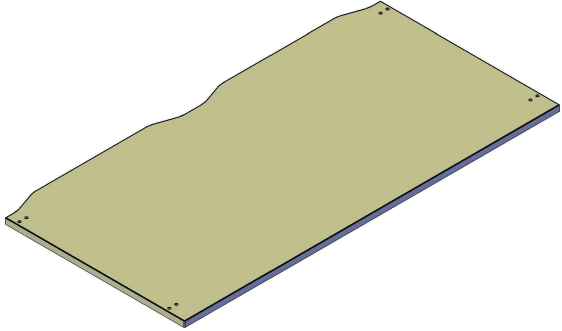

**1 x TABLE TOP**

1600mm Deep Tops

1200mm = EDBT1216T  
1600mm = EDBT1616T

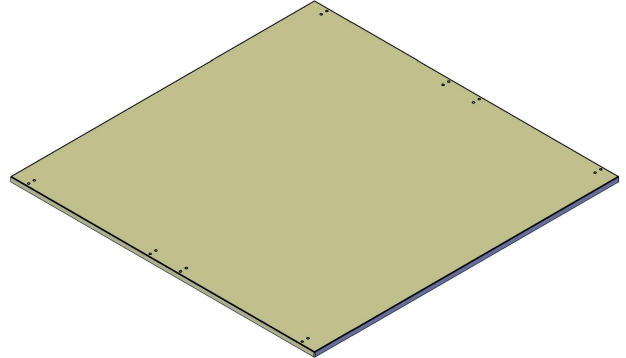

**or**

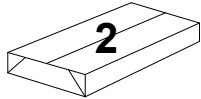



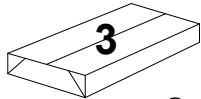

**2 x OUTER LEG FRAMES ( FZ1600OL )**

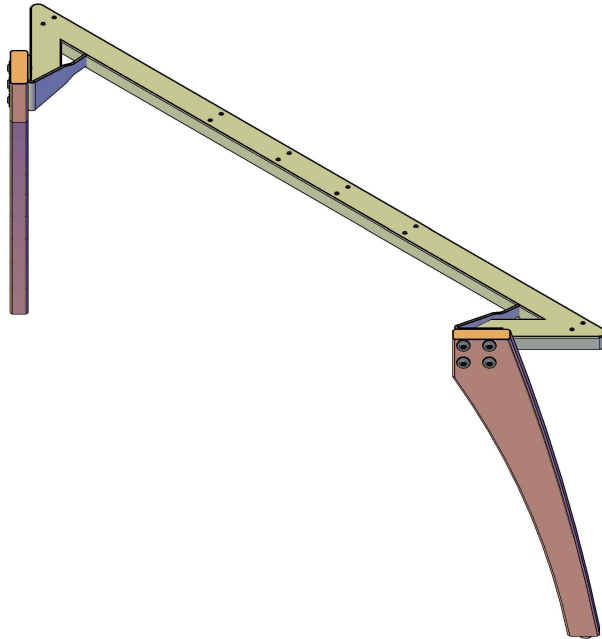

**2 x OUTER LEG PANELS ( FZW-1 )**

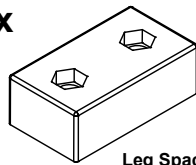
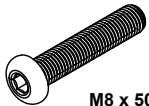
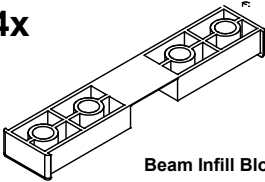

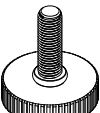
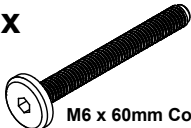
### FITTINGS SUPPLIED WITH EACH LEG

<b>4x</b>  Leg Spacer Block	<b>4x</b>  M8 x 50mm Bolt
<b>4x</b>  Beam Infill Block	<b>4x</b>  8mm Washer
<b>2x</b>  M8 Adjustable Foot	<b>8x</b>  M6 x 60mm Connect Bolt
	<b>8x</b>  M6 x 25mm Connect Bolt

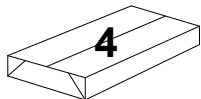

**2 x BEAM PACK**

1200mm = ED12BM  
1400mm = ED14BM  
1600mm = ED16BM

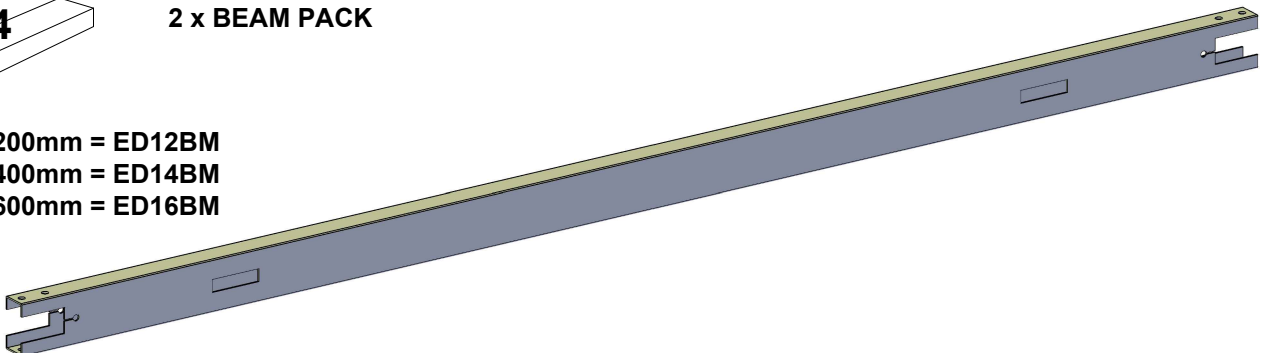

# Back to Back Desk Assembly

1

## Step 1

Insert the beam infill blocks into both ends of the beam.

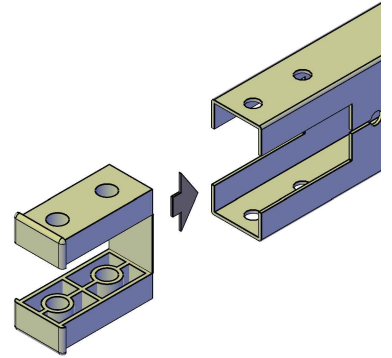
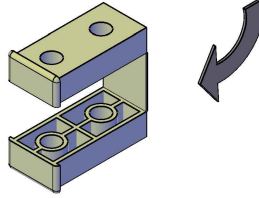
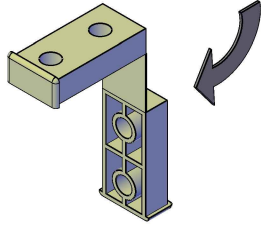
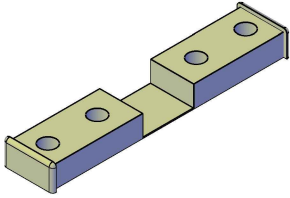

2

## Step 2

Push the beams onto the 1st leg frame lining up the beam holes with the M6 threaded holes on the leg.

Ensure the screen fixing points on the outer leg and cut out slots on the beams are facing inwards.

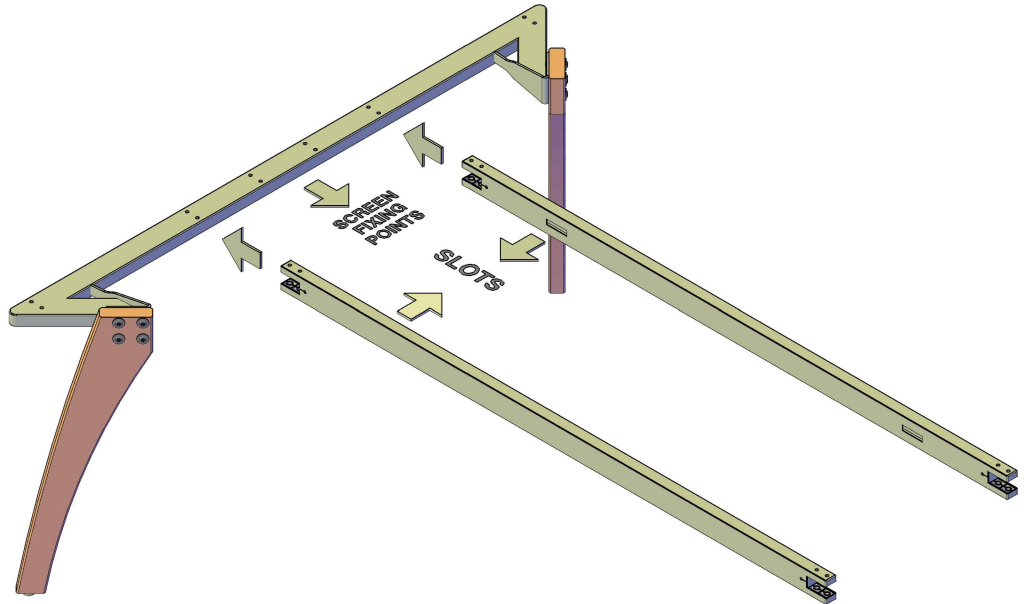

3

## Step 3

Once the holes are aligned fix the beam in place using the M6 x 25mm Connect Bolts.

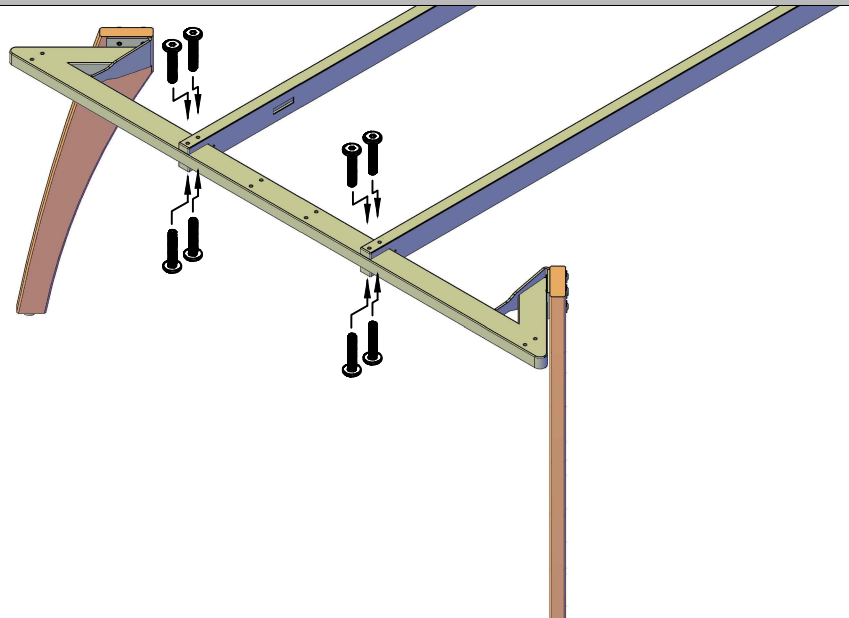

8x

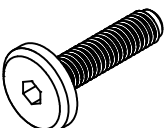

M6 x 25mm Connect Bolt

# 4

## Step 4

Push the beams onto the remaining leg frame lining up the beam holes with the M6 threaded holes on the leg.

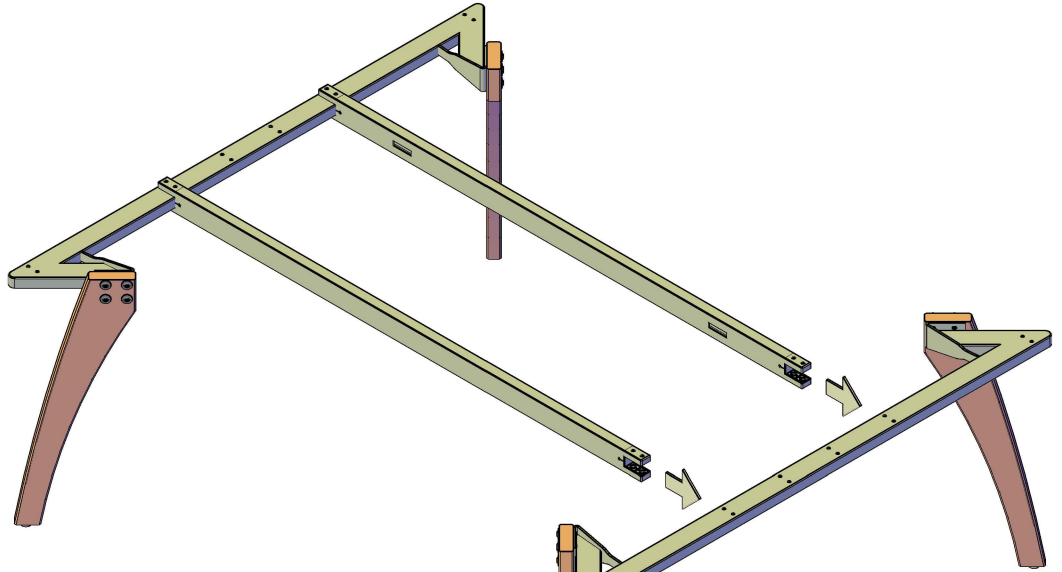

### Please Note

If you have purchased a larger configuration of desk than the one shown please refer to the FZ1600IL instruction before proceeding with step 4

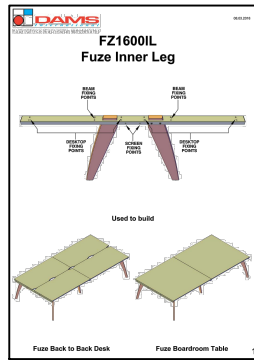

# 5

## Step 5

Once the holes are aligned fix the beam in place using the M6 x 25mm Connect Bolts.

8x

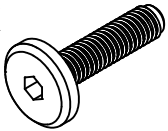

M6 x 25mm Connect Bolt

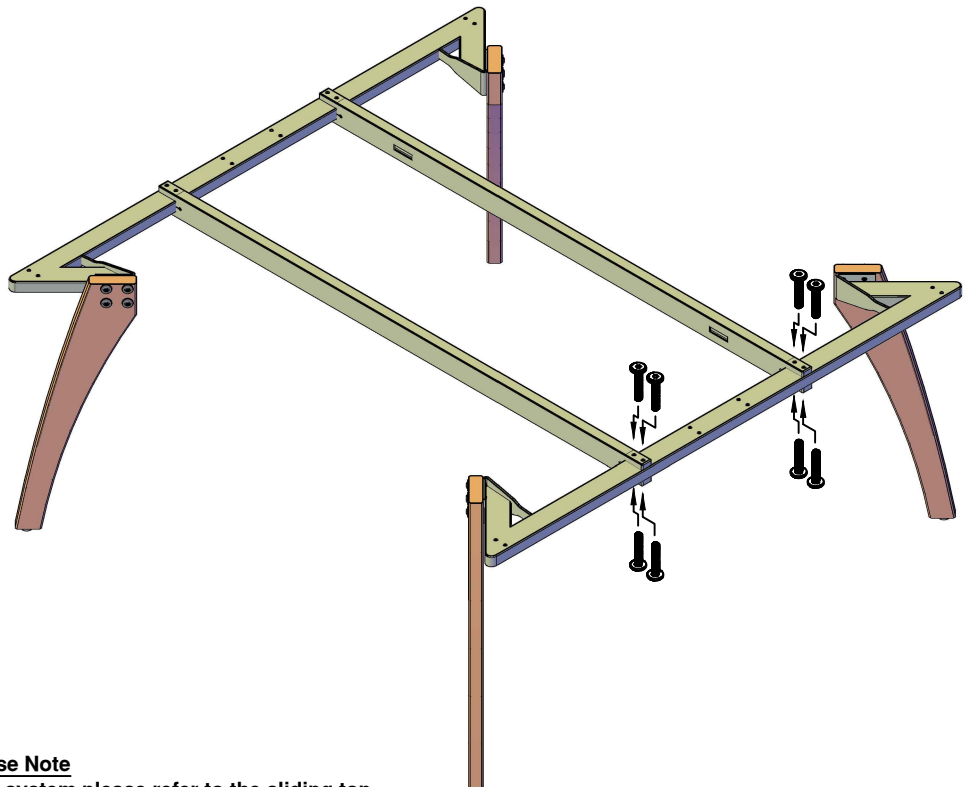

### Please Note

If you have purchased a sliding top system please refer to the sliding top bracket assembly instruction from this point onwards.

**Step 6**

**Position the Spacer Blocks over the holes in the leg frames.**

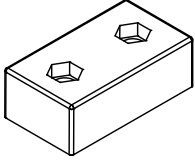
**8x**

Leg Spacer Block

**Ensure that the spacer blocks are placed onto the frame with the recessed nut holes facing upwards.**

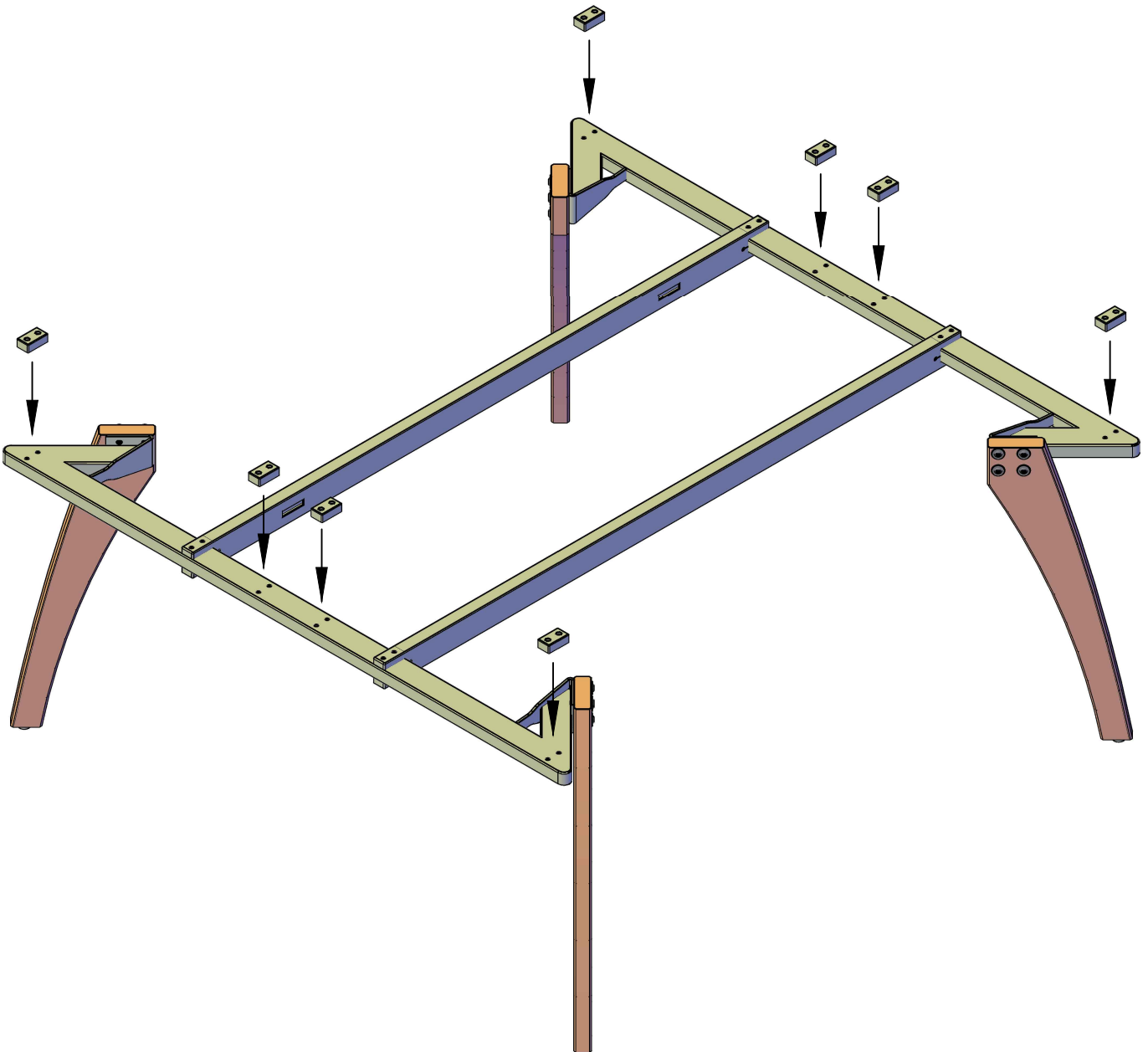
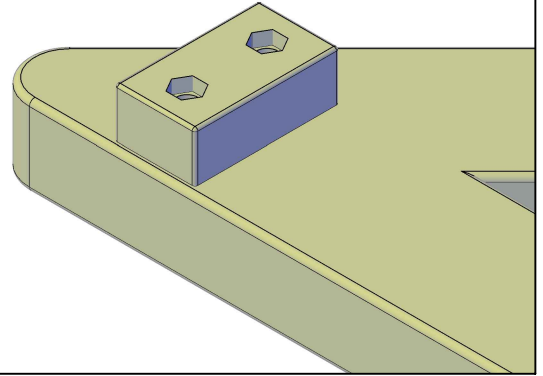
**Please Note**

**For ease of assembly Screen Brackets and Horizontal Cable Trays should be fitted before you proceed to Step 7.**

### Step 7

Place the desktop onto the assembled framework ensuring that the edges of the desktop finish parallel with the end of the leg frames.

The framework may be slightly out of square, if this happens loosen the fixing bolts in the beams and align correctly before re tightening the bolts.

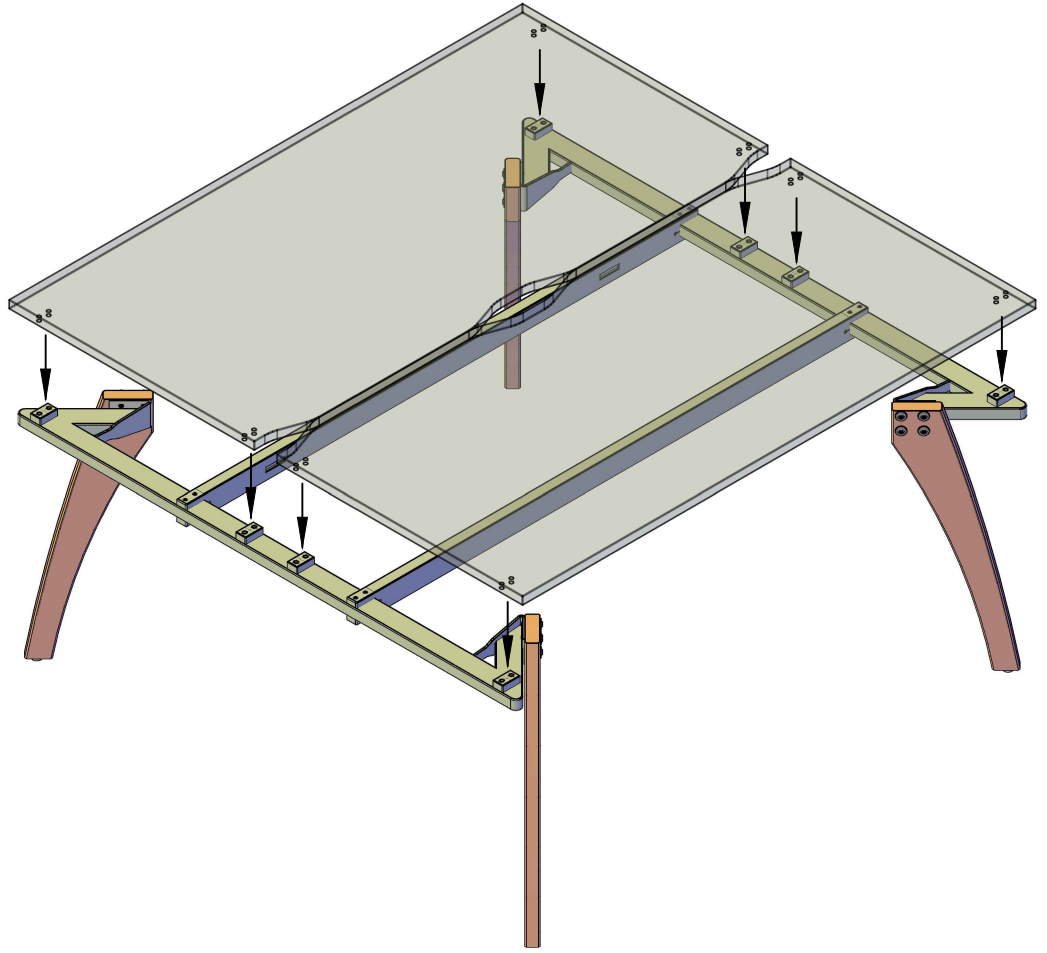

or

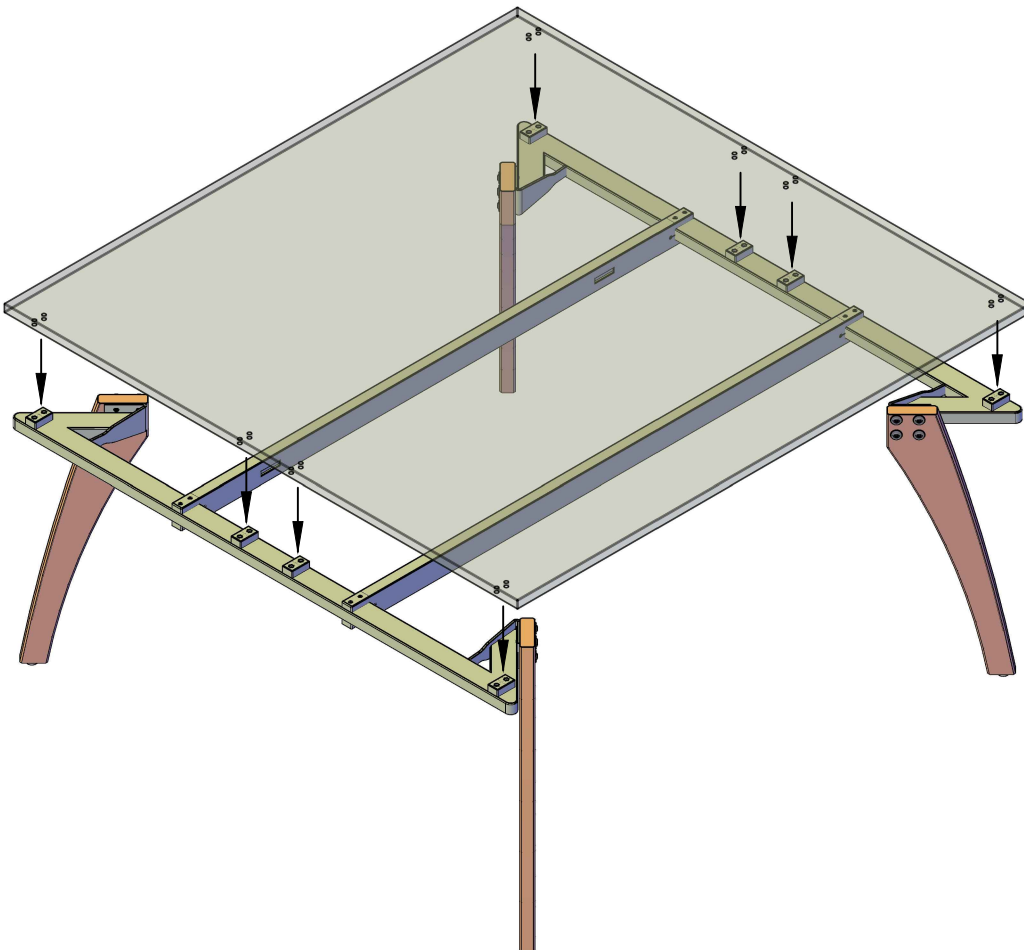

**Step 8**

Attach one side of the desktops to the frame using the M6 x 60mm Connect Bolts.

Ensure that the bolt passes through both the leg frame and Spacer Block.

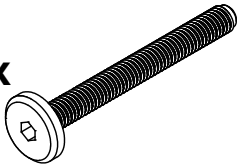
**8x**

M6 x 60mm Connect Bolt

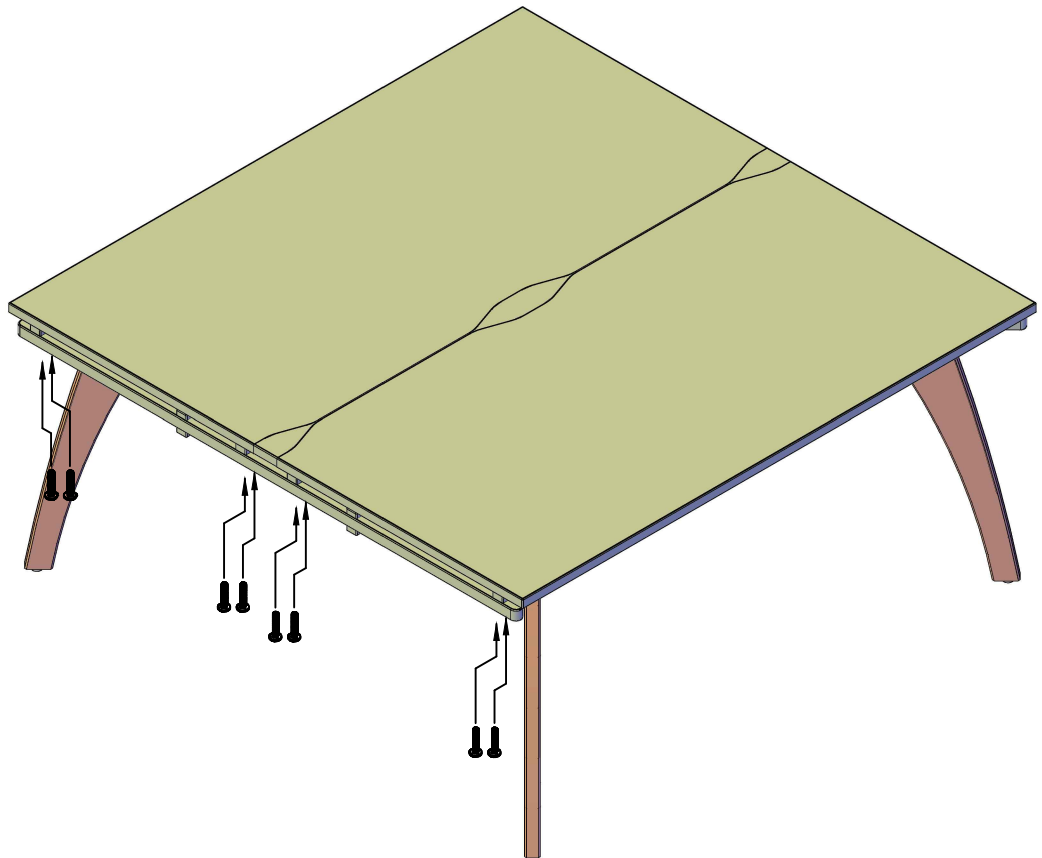
**Step 9**

Attach the remaining side of the desktops to the frame using the M6 x 60mm Connect Bolts.

Ensure that the bolt passes through both the leg frame and Spacer Block.

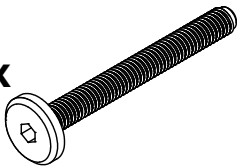
**8x**

M6 x 60mm Connect Bolt

