

Business or pleasure.
Works both ways.

Boulevard Cafe Desk

Model 5420701

NOTE: THIS INSTRUCTION BOOKLET CONTAINS **IMPORTANT** SAFETY INFORMATION.

PLEASE READ AND KEEP FOR FUTURE REFERENCE.

Table of Contents

Assembly Tools Required

Part Identification	3
Hardware Identification	4
Assembly Steps	5-21
Français	22-24
Español	25-27
Safety	28-30
Warranty	31

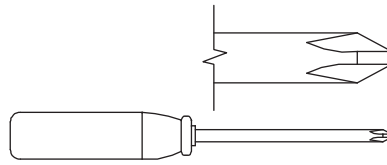

No. 2 Phillips Screwdriver
Tip Shown Actual Size

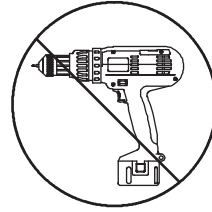

Skip the power trip.
This time.

Part Identification

Now you know
our ABCs.

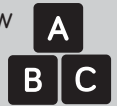

↑ While not all parts are labeled, some of the parts will have a label or an inked letter on the edge to help distinguish similar parts from each other. Use this part identification to help identify similar parts.

A	RIGHT END (1)	H	SHELF (1)	O	DRAWER BOTTOM (1)
B	LEFT END (1)	I	MODESTY PANEL (1)	P	LARGE RIGHT DRAWER SIDE (2)
C	RIGHT UPRIGHT (1)	J	DRAWER FRONT (1)	Q	LARGE LEFT DRAWER SIDE (2)
D	LEFT UPRIGHT (1)	K	LARGE DRAWER FRONT (2)	R	LARGE DRAWER BACK (2)
E	TOP (1)	L	RIGHT DRAWER SIDE (1)	S	LARGE DRAWER BOTTOM (2)
F	BOTTOM (2)	M	LEFT DRAWER SIDE (1)		
G	BACK (2)	N	DRAWER BACK (1)		

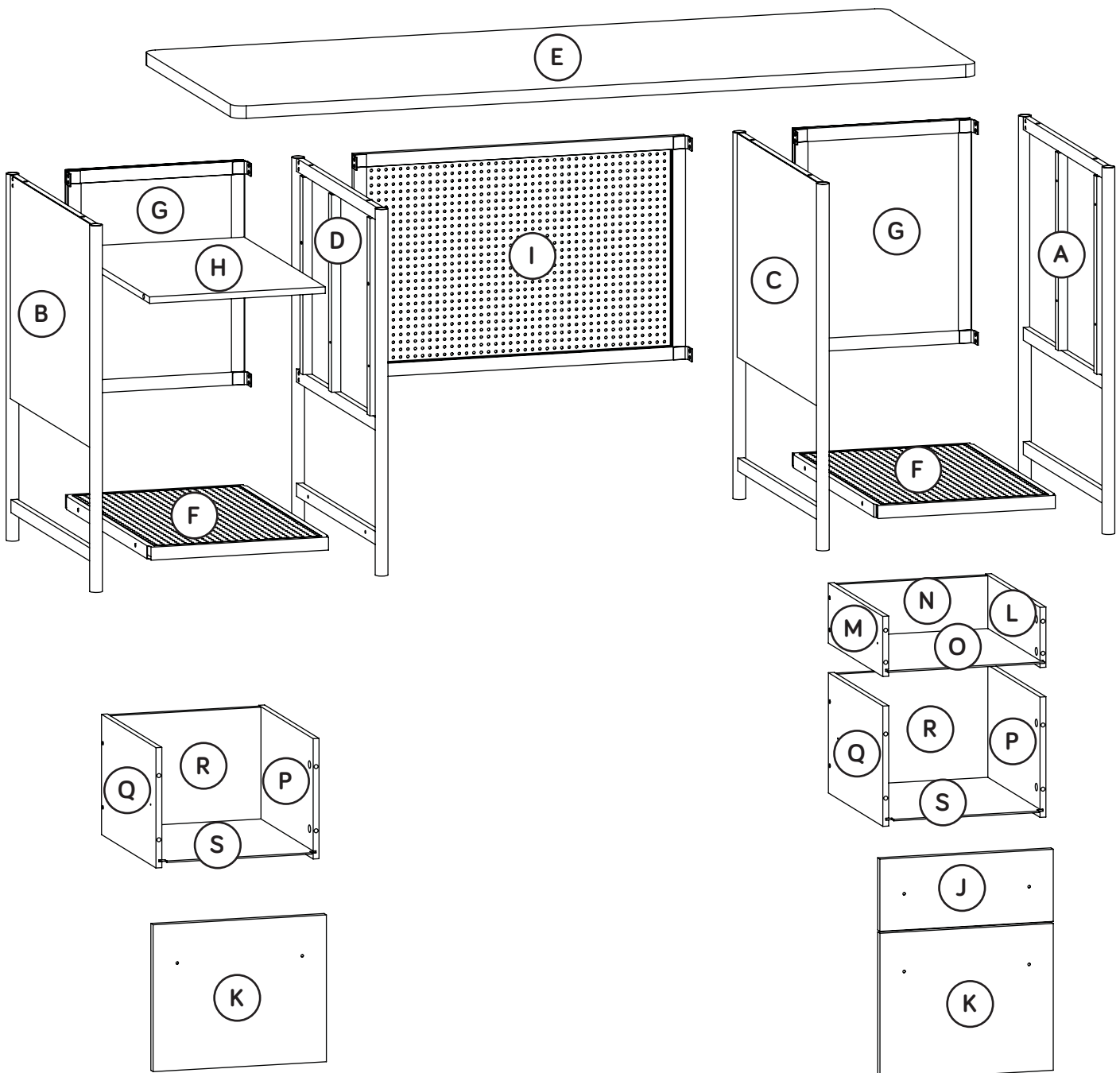

Hardware Identification

† Screws are shown actual size. You may receive extra hardware with your unit.

(EXTENSION SET SHOWN SEPARATED)

1 EXTENSION RAIL - 6

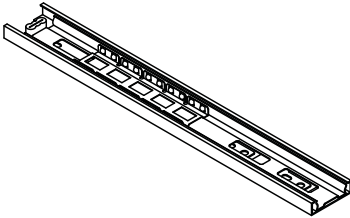

2 EXTENSION SLIDE - 6

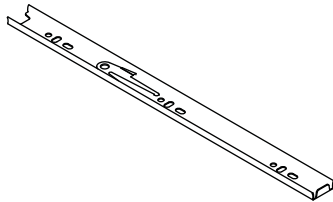

3 HIDDEN CAM - 12



4 CAM SCREW - 12

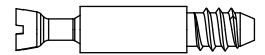

5 FILE GLIDE - 4

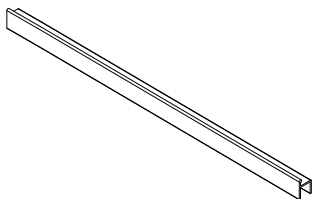

6 FILE HANGER - 4

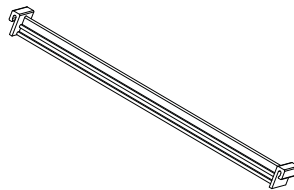

7 PULL - 3

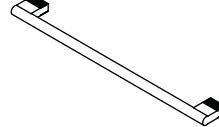

8 ADJUSTABLE GLIDE - 8

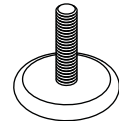

9 APPLIQUE CARD - 1

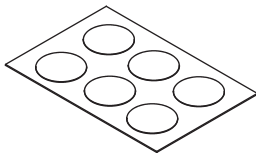

10 BUMPER CARD - 1

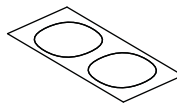

11 L- WRENCH - 1

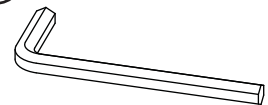

12 BLACK 1-5/8" WAFER HEAD SCREW - 12

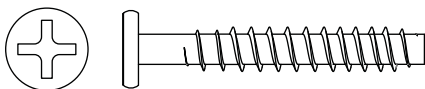

13 BLACK 1-1/2" FLAT HEAD SCREW - 12

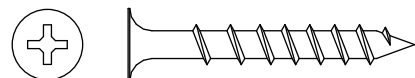

14 BLACK 3/4" HEX HEAD SCREW - 8

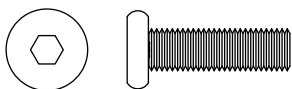

15 BLACK 1/2" WAFER HEAD SCREW - 4

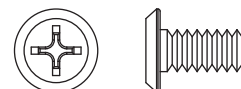

16 BLACK 1/2" MACHINE SCREW - 12

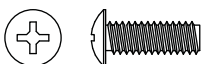

17 BLACK 1/2" PAN HEAD SCREW - 18



18 BLACK 3/8" MACHINE SCREW - 6

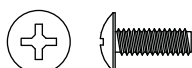

19 BLACK 5/16" WAFER HEAD SCREW - 24



Step 1

- ✚ Assemble your unit on a carpeted floor or on the empty carton to avoid scratching your unit or the floor.
- ✚ Fasten a BACK (G) to the RIGHT END (A) and RIGHT UPRIGHT (C). Use eight BLACK 5/16" WAFER HEAD SCREWS (19).
- ✚ **NOTE:** You should start each SCREW a few turns before completely tightening any of them.



Some assembly
(and snacks) required.

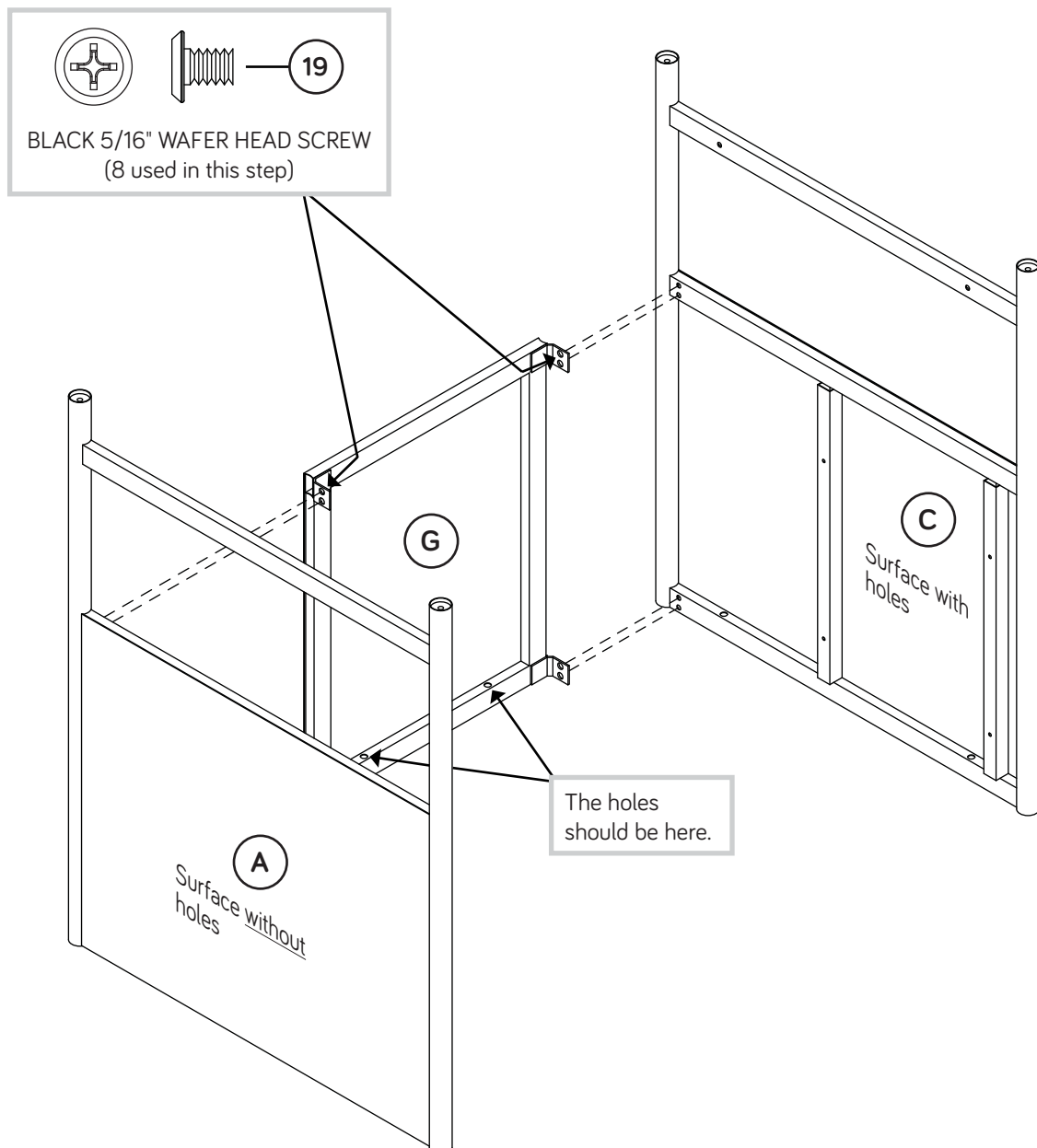

Step 2

✚ Fasten the other BACK (G) to the LEFT END (B) and LEFT UPRIGHT (D). Use eight BLACK 5/16" WAFER HEAD SCREWS (19).

✚ NOTE: You should start each SCREW a few turns before completely tightening any of them.

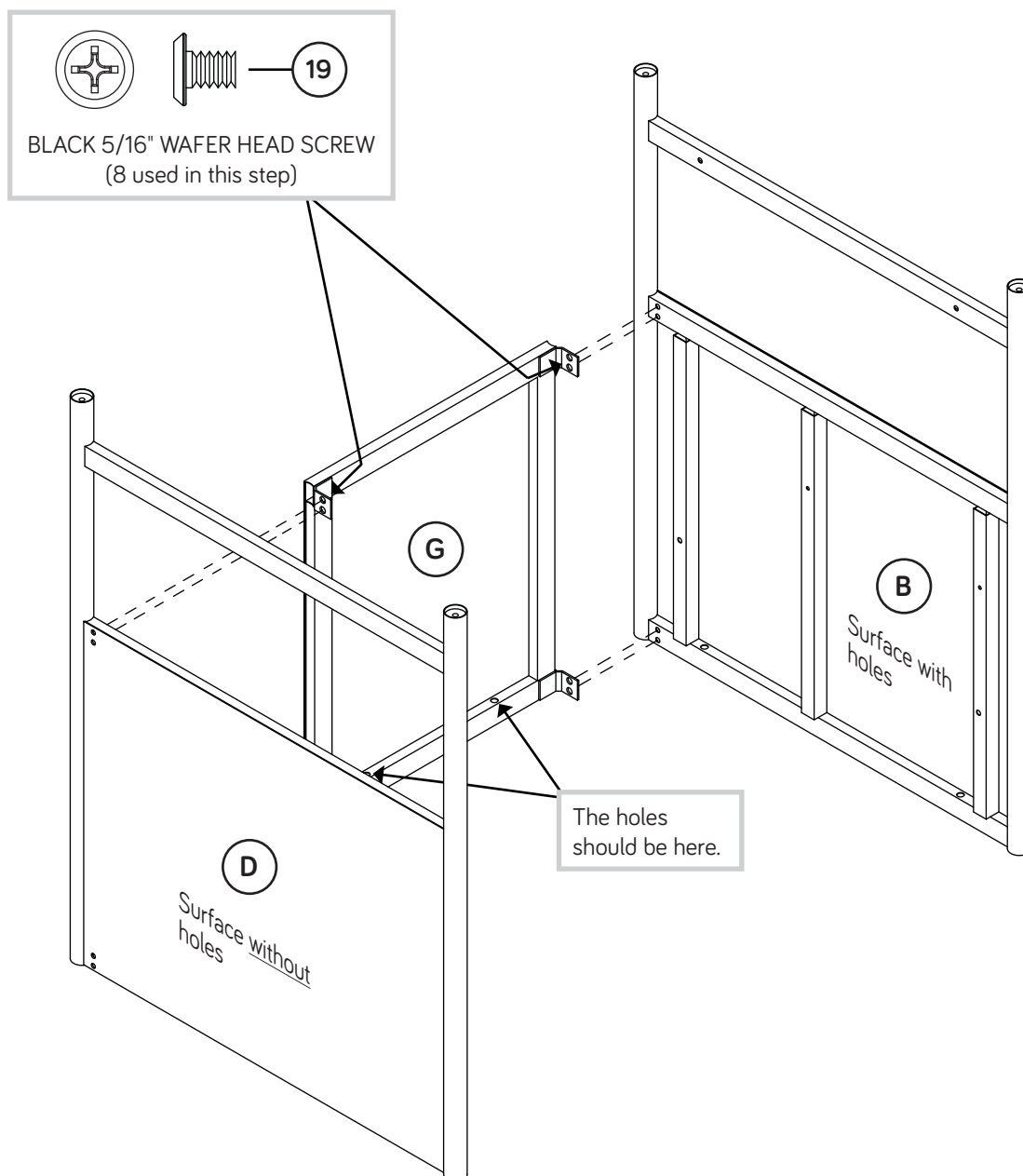

Step 3

Fasten the MODESTY PANEL (I) to the UPRIGHTS (C and D). Use eight BLACK 5/16" WAFER HEAD SCREWS (19).

NOTE: You should start each SCREW a few turns before completely tightening any of them.

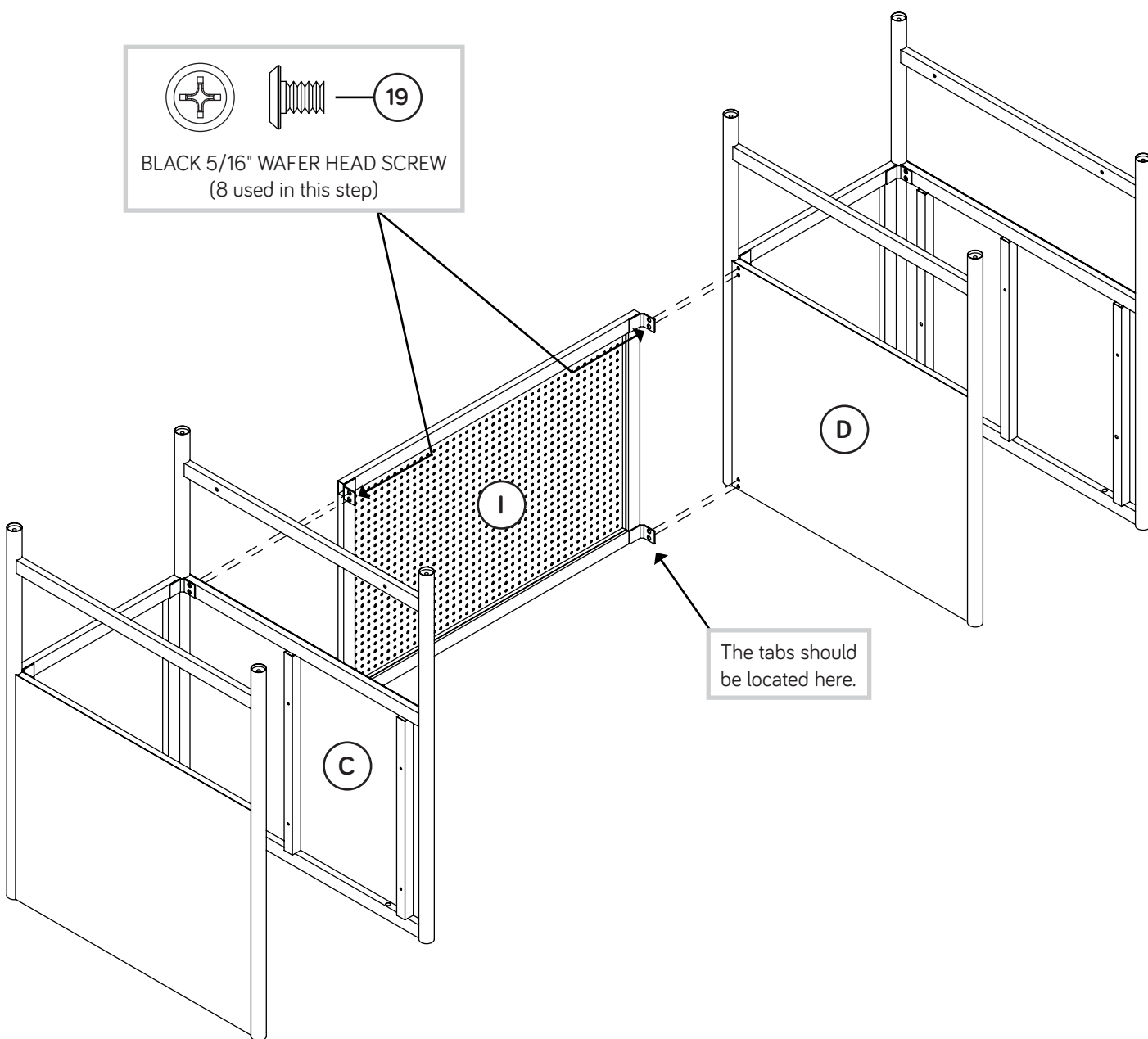

Step 4

- ⚡ **NOTE:** You may need someone's help in this step.
- ⚡ Fasten the ENDS (A and B), UPRIGHTS (C and D), and BACKS (G) to the TOP (E). Use twelve BLACK 1-5/8" WAFER HEAD SCREWS (12).
- ⚡ **NOTE:** You should start each SCREW a few turns before completely tightening any of them.

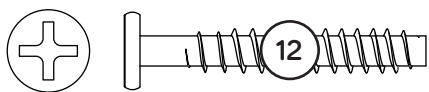

BLACK 1-5/8" WAFER HEAD SCREW
(12 used in this step)

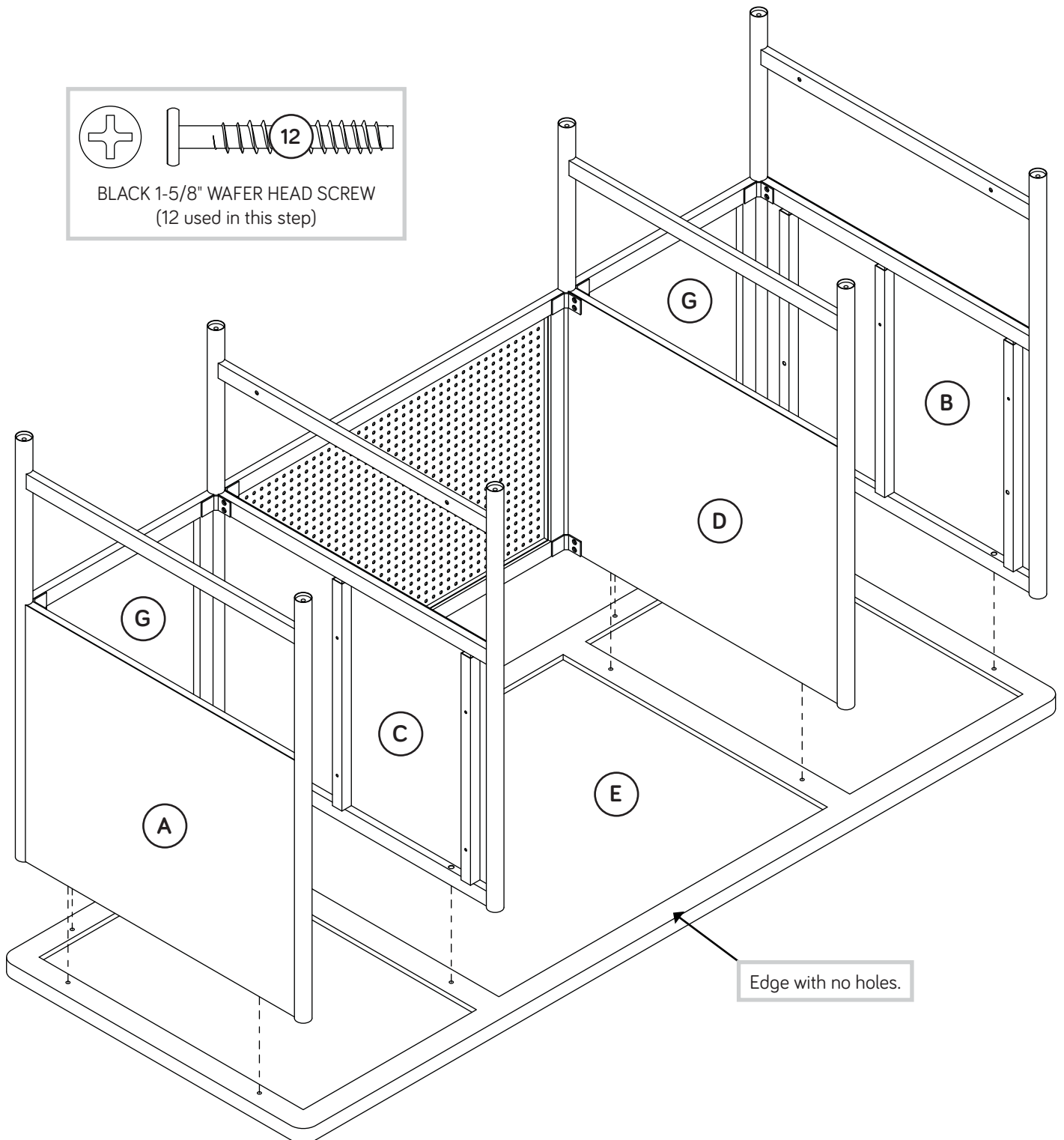

Step 5

Fasten the SHELF (H) to the LEFT END (B) and LEFT UPRIGHT (D). Use four BLACK 1/2" WAFER HEAD SCREWS (15).

NOTE: You should start each SCREW a few turns before completely tightening any of them.

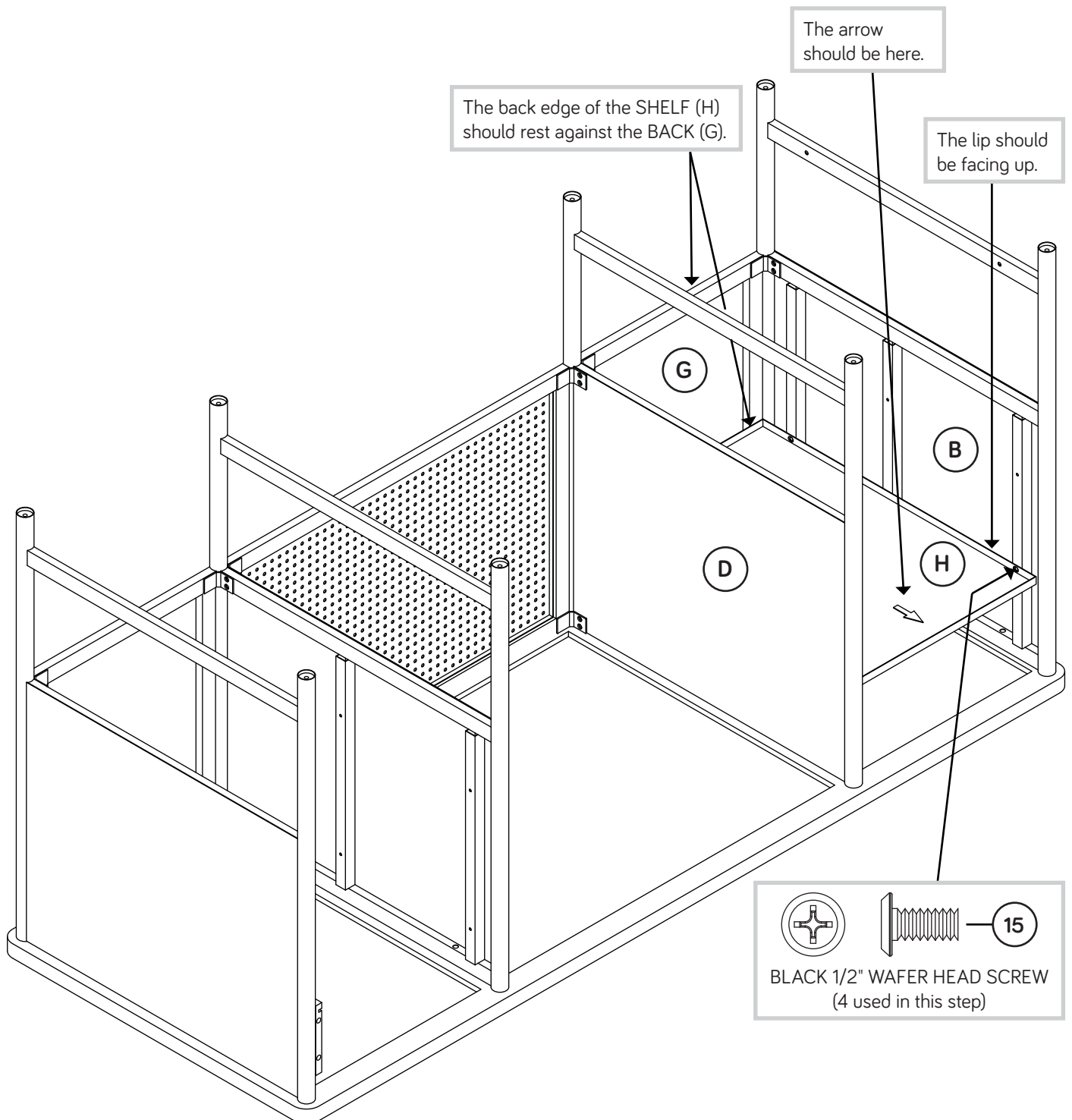

Step 6

Fasten the BOTTOMS (F) to the ENDS (A and B) and UPRIGHTS (C and D). Use eight BLACK 3/4" HEX HEAD SCREWS (14) and tighten with the L-WRENCH (11).

NOTE: You should start each SCREW a few turns before completely tightening any of them.

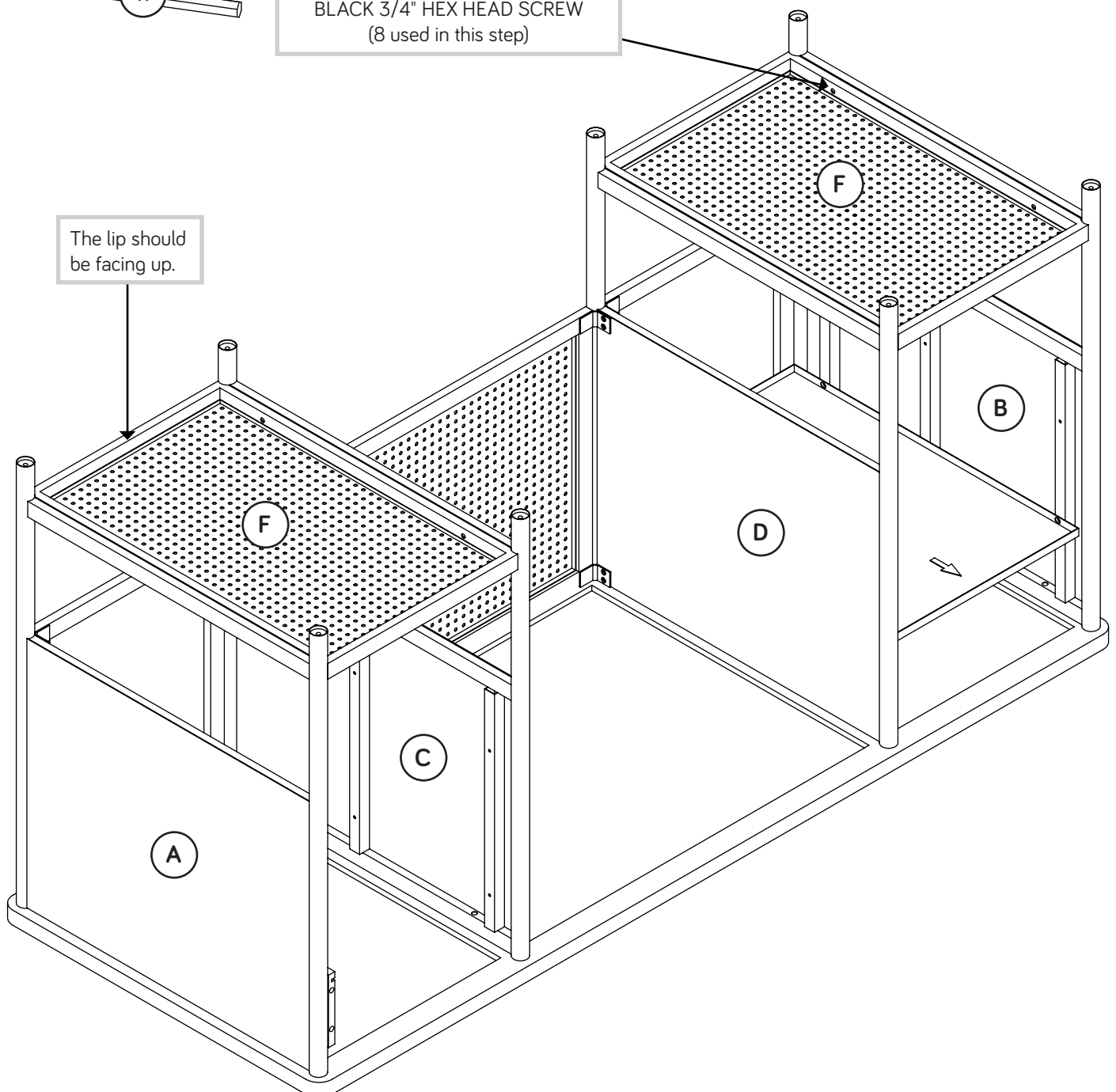
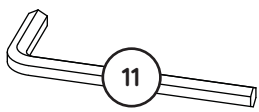

Step 7

- ✦ Separate the EXTENSION SLIDES (2) from the EXTENSION RAILS (1) as shown in the upper diagram below. Be prepared, the parts are greasy.
- ✦ Fasten six EXTENSION RAILS (1) to the ENDS (A and B) and UPRIGHTS (C and D). Use twelve BLACK 1/2" MACHINE SCREWS (16).
- ✦ **NOTE:** For each EXTENSION RAIL, turn a SCREW into the hole shown in the enlarged diagram. Then, slide the inner cartridge of the EXTENSION RAIL in to find the other hole that lines up with the hole in the ENDS and UPRIGHTS. Turn a SCREW into this hole.
- ✦ **NOTE:** The EXTENSION SLIDES will be used later for the DRAWERS.

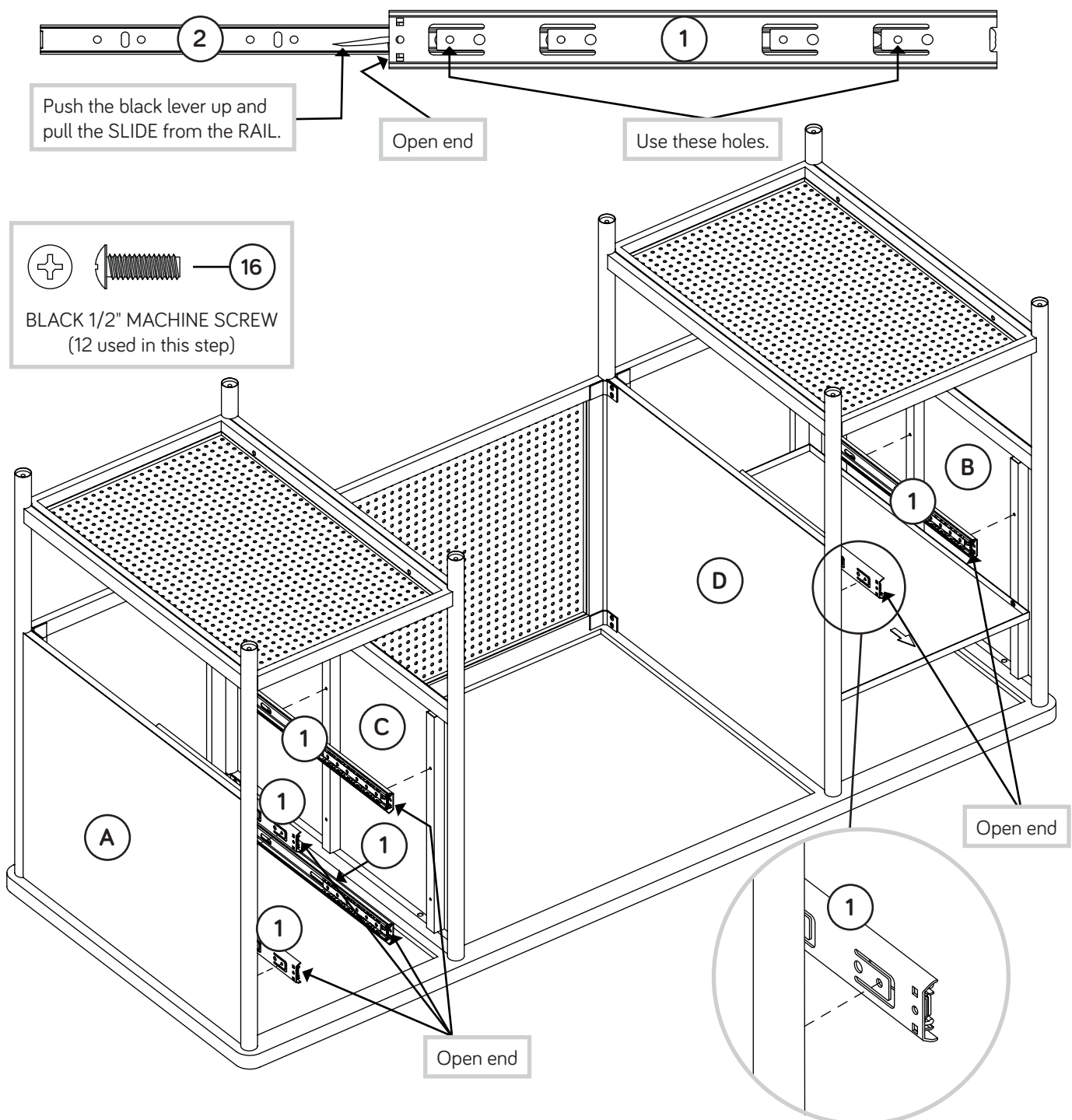

Step 8

Turn eight ADJUSTABLE GLIDES (8) into the bottom of the ENDS (A and B) and UPRIGHTS (C and D).

NOTE: Turn the ADJUSTABLE GLIDES completely in. Final adjustments will be made after the unit is standing upright.



Now might be a good time to refresh your drink.

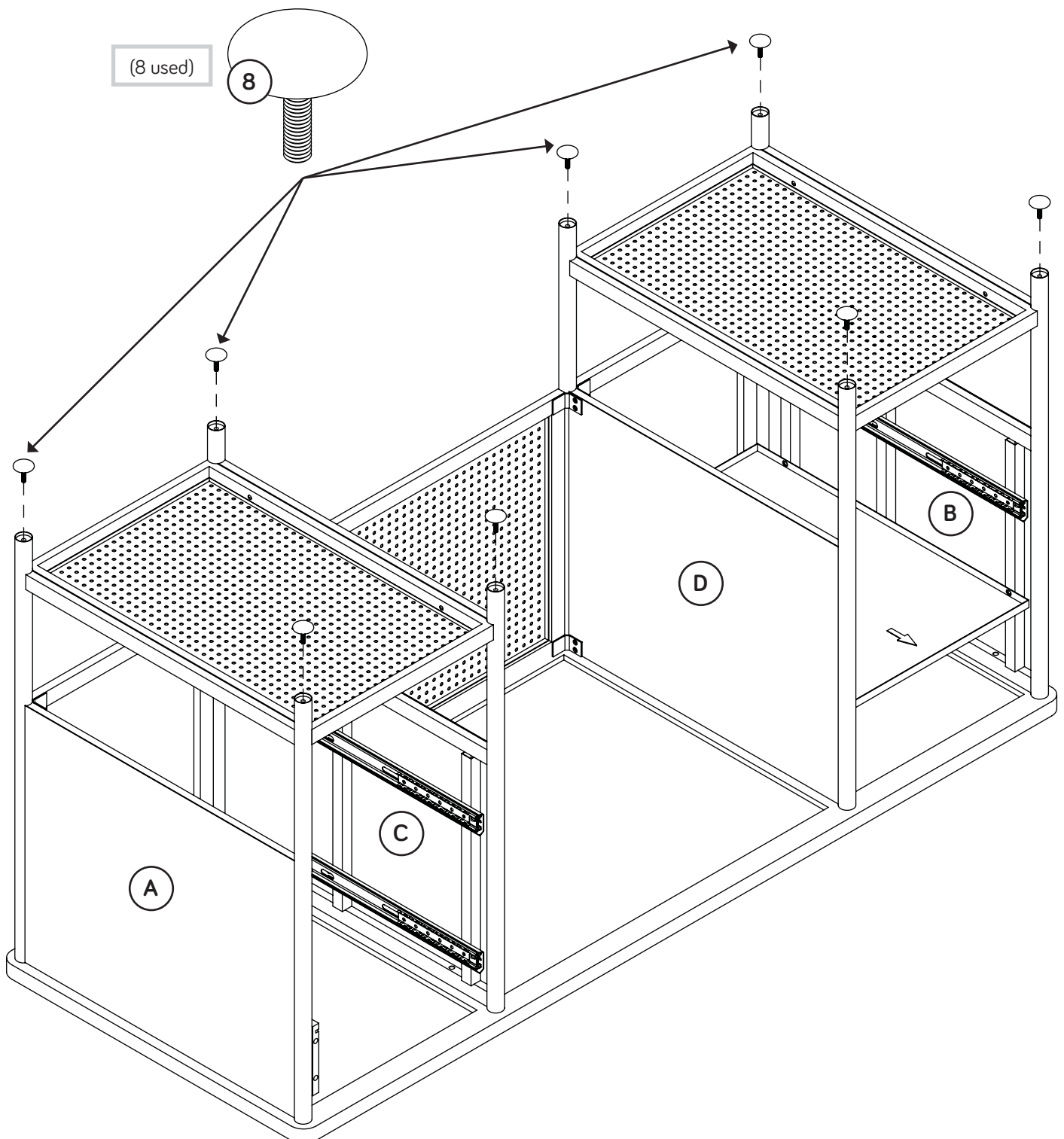

Step 9

- Push twelve HIDDEN CAMS (3) into the DRAWER SIDES (L and M) and LARGE DRAWER SIDES (P and Q).

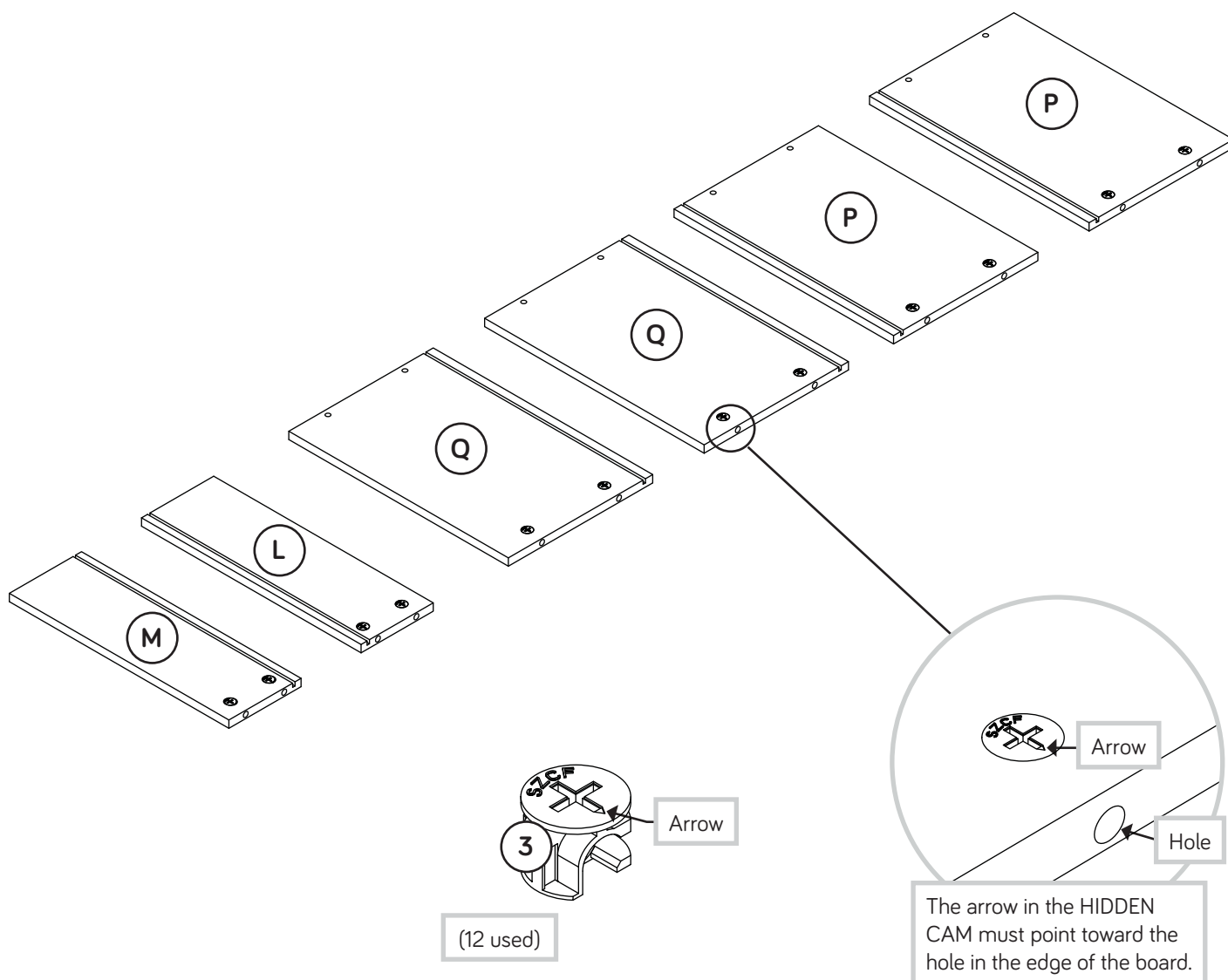

Step 10

Turn twelve CAM SCREWS (4) into the exact holes shown in the DRAWER FRONTS (J and K).

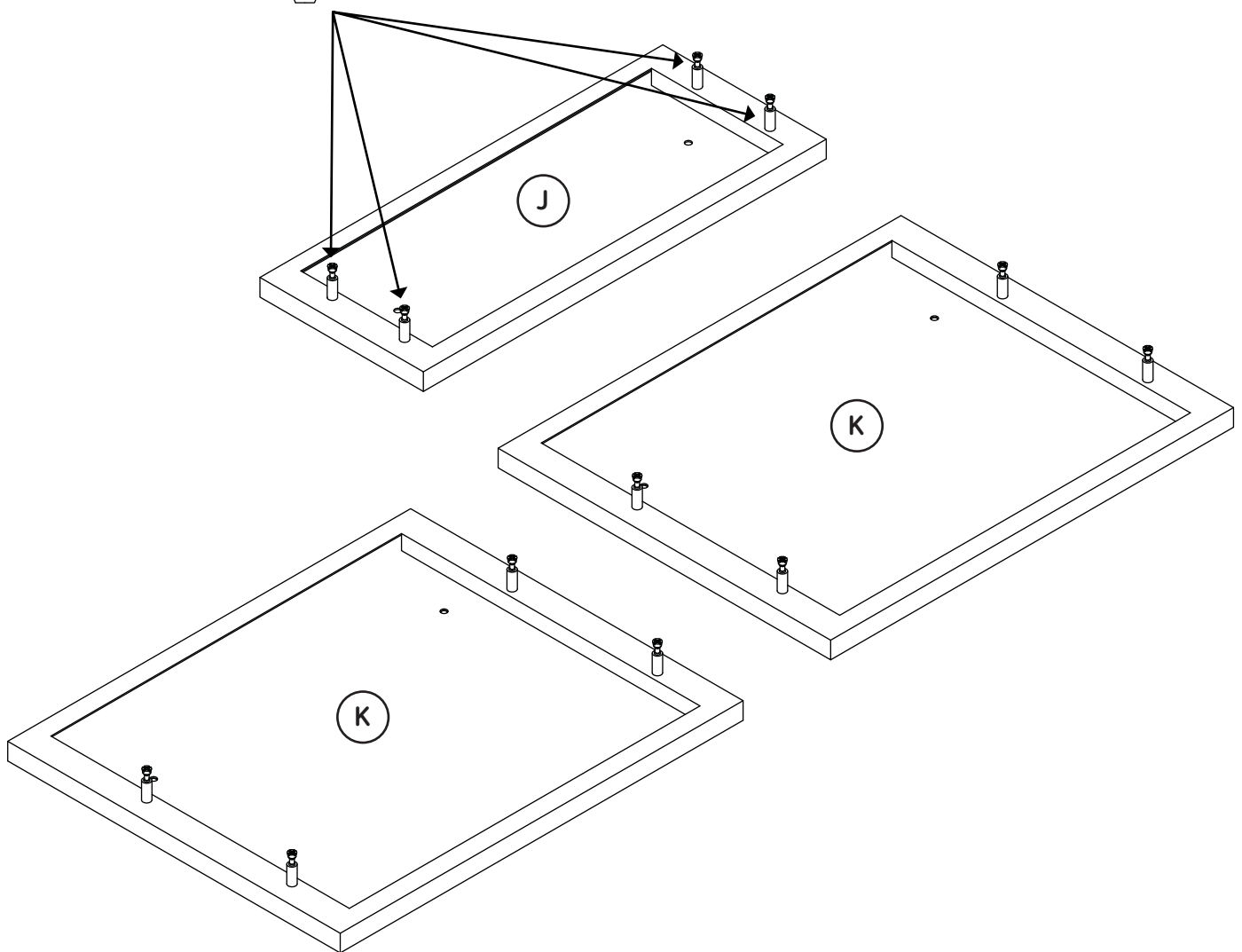
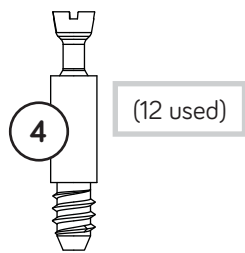
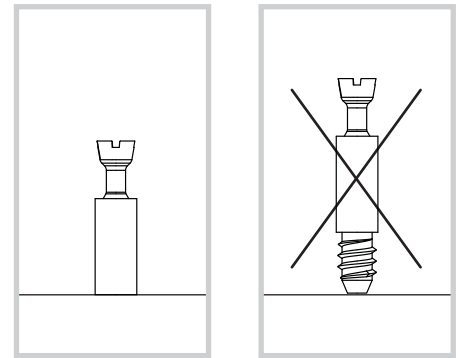

Step 11

1

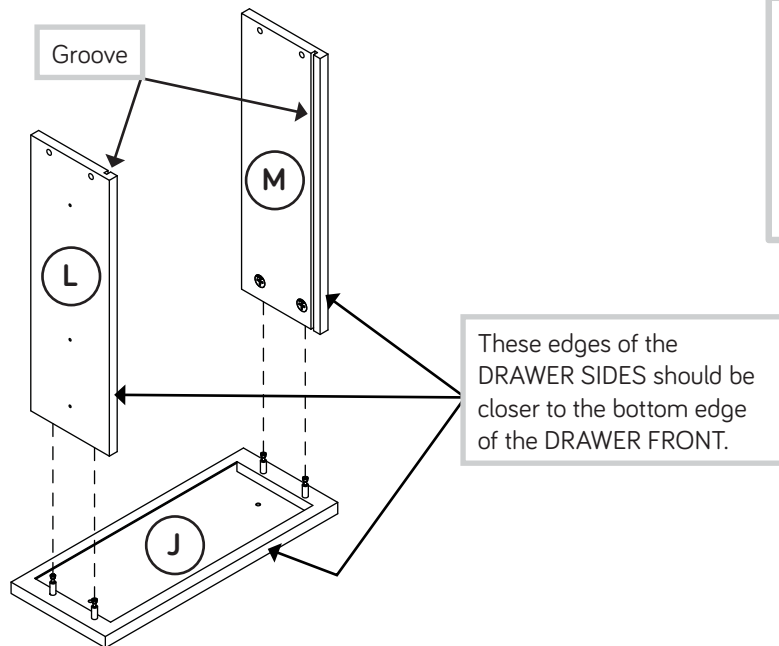

Fasten the DRAWER SIDES (L and M) to the DRAWER FRONT (J). Tighten four HIDDEN CAMS.

2

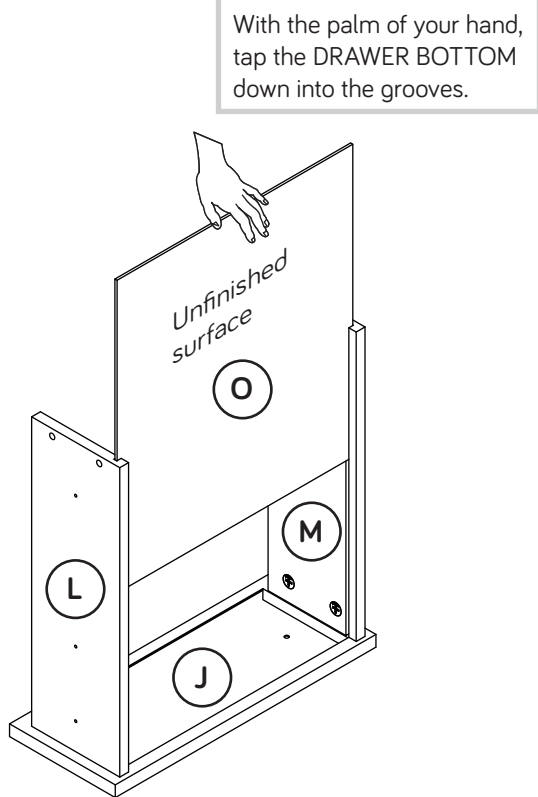

Slide the DRAWER BOTTOM (O) into the grooves in the DRAWER SIDES (L and M).

3

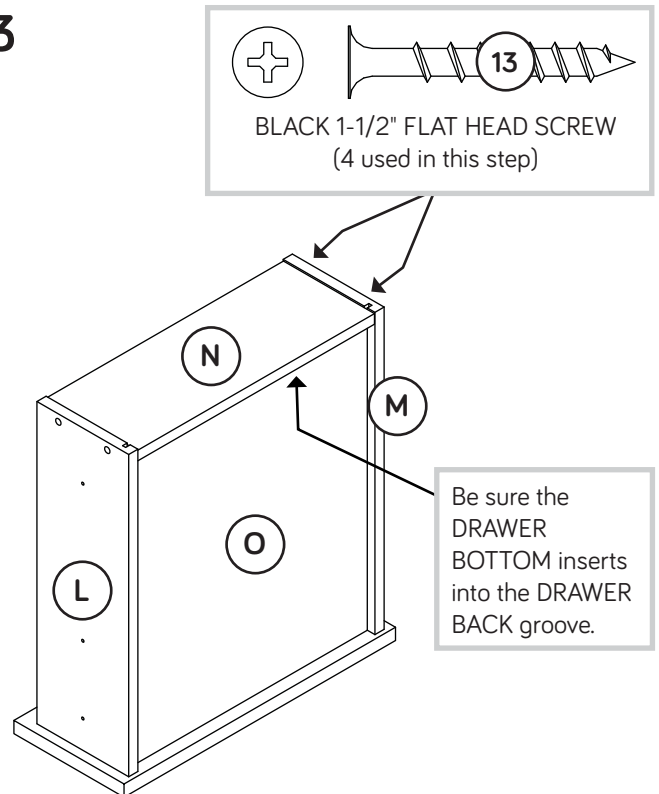

Fasten the DRAWER BACK (N) to the DRAWER SIDES (L and M). Use four BLACK 1-1/2" FLAT HEAD SCREWS (13).

NOTE: Be sure the DRAWER BOTTOM (O) inserts into the groove of the DRAWER BACK (N).

Step 12

- Fasten two EXTENSION SLIDES (2) to the DRAWER SIDES (L and M). Use six BLACK 1/2" PAN HEAD SCREWS (17).
- Peel four STICKERS from the APPLIQUE CARD (9) and stick one onto each HIDDEN CAM in the drawer.
- Fasten the PULL (7) to the DRAWER FRONT (J). Use two BLACK 3/8" MACHINE SCREWS (18).

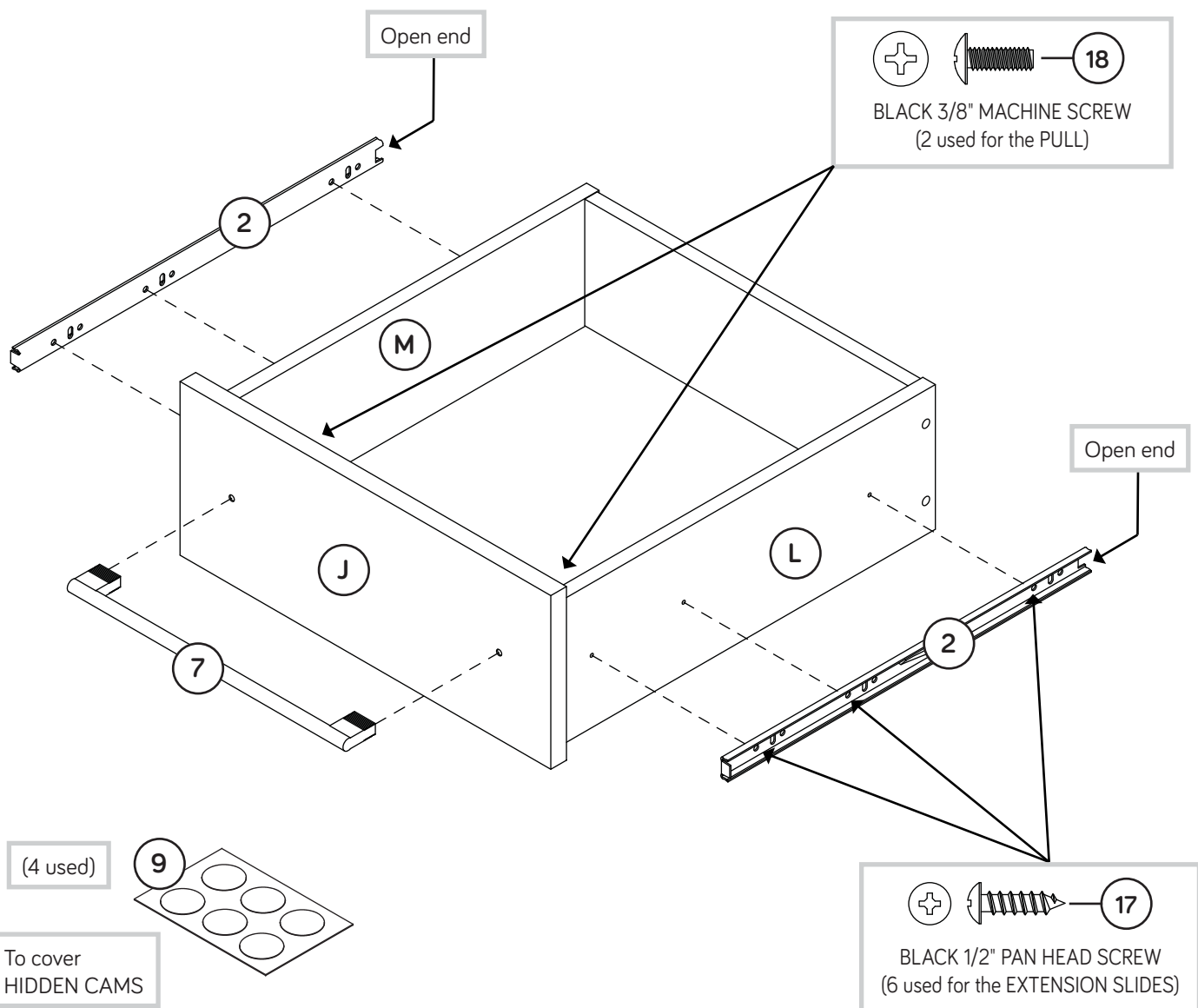
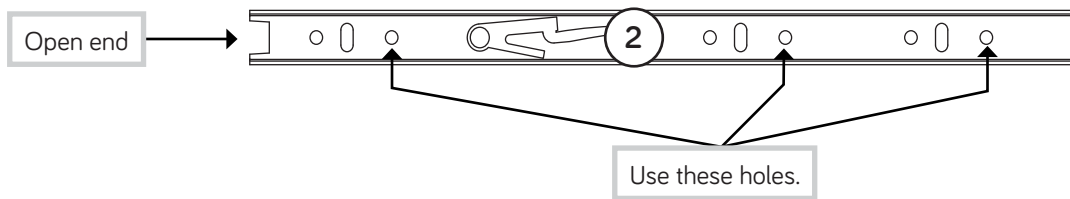

Step 13

1

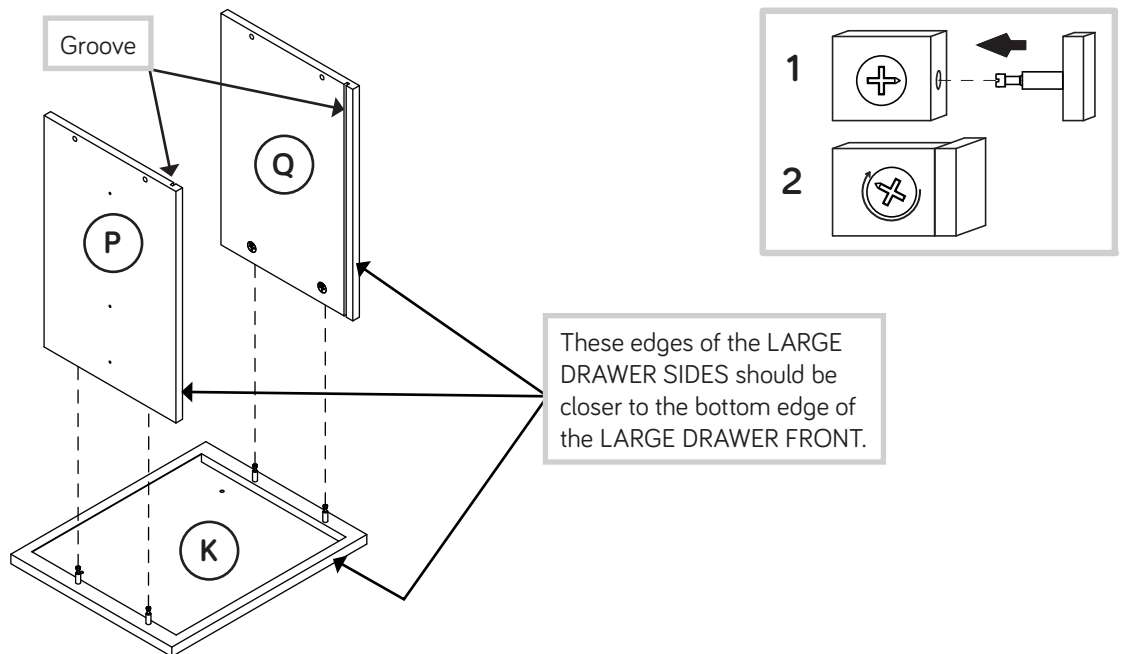

🔩 Fasten the LARGE DRAWER SIDES (P and Q) to the LARGE DRAWER FRONT (K). Tighten four HIDDEN CAMS.

2

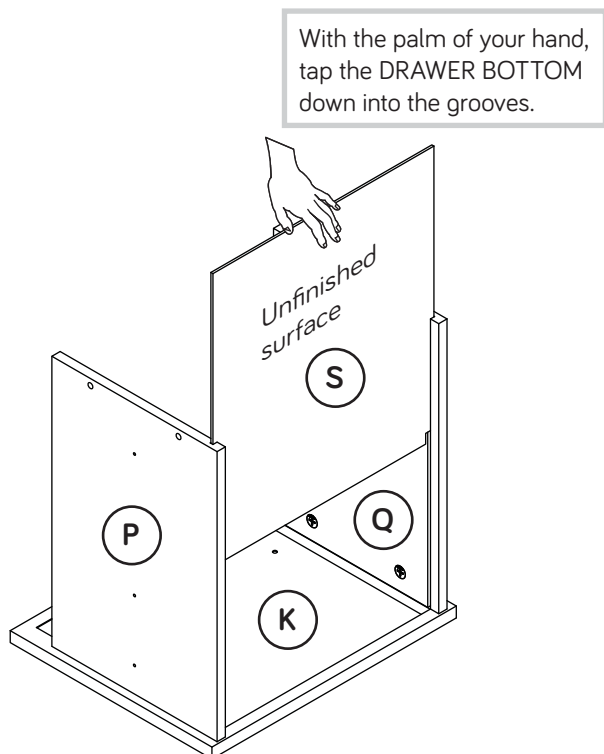

🔩 Slide the LARGE DRAWER BOTTOM (S) into the grooves in the LARGE DRAWER SIDES (P and Q).

3

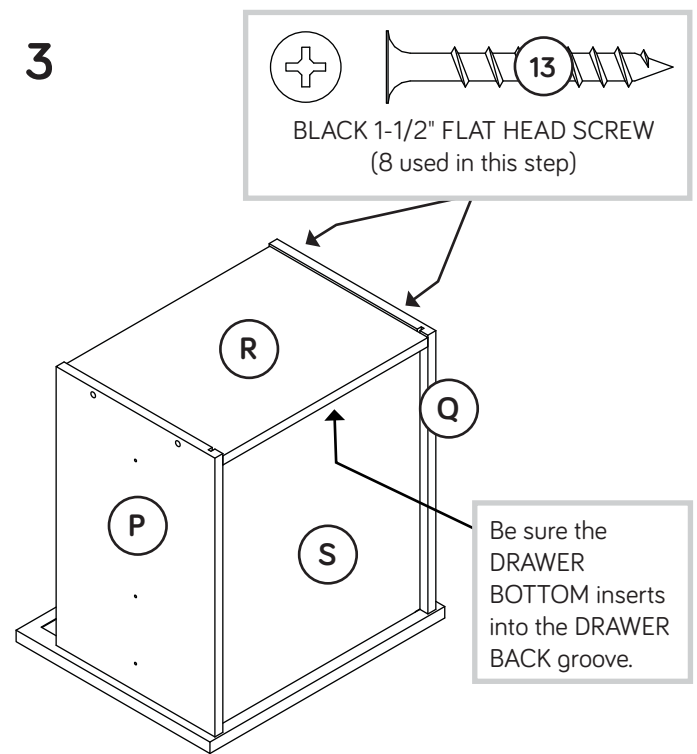

🔩 Fasten the LARGE DRAWER BACK (R) to the LARGE DRAWER SIDES (P and Q). Use four BLACK 1-1/2" FLAT HEAD SCREWS (13).

🔩 **NOTE:** Be sure the LARGE DRAWER BOTTOM (S) inserts into the groove of the LARGE DRAWER BACK (R).

🔩 Repeat this step for the other large drawer.

Step 14

- Fasten two EXTENSION SLIDES (2) to the LARGE DRAWER SIDES (P and Q). Use six BLACK 1/2" PAN HEAD SCREWS (17).
- Peel four STICKERS from the APPLIQUE CARD (9) and stick one onto each HIDDEN CAM in the large drawer.
- Fasten the PULL (7) to the LARGE DRAWER FRONT (K). Use two BLACK 3/8" MACHINE SCREWS (18).
- Repeat this step for the other large drawer.

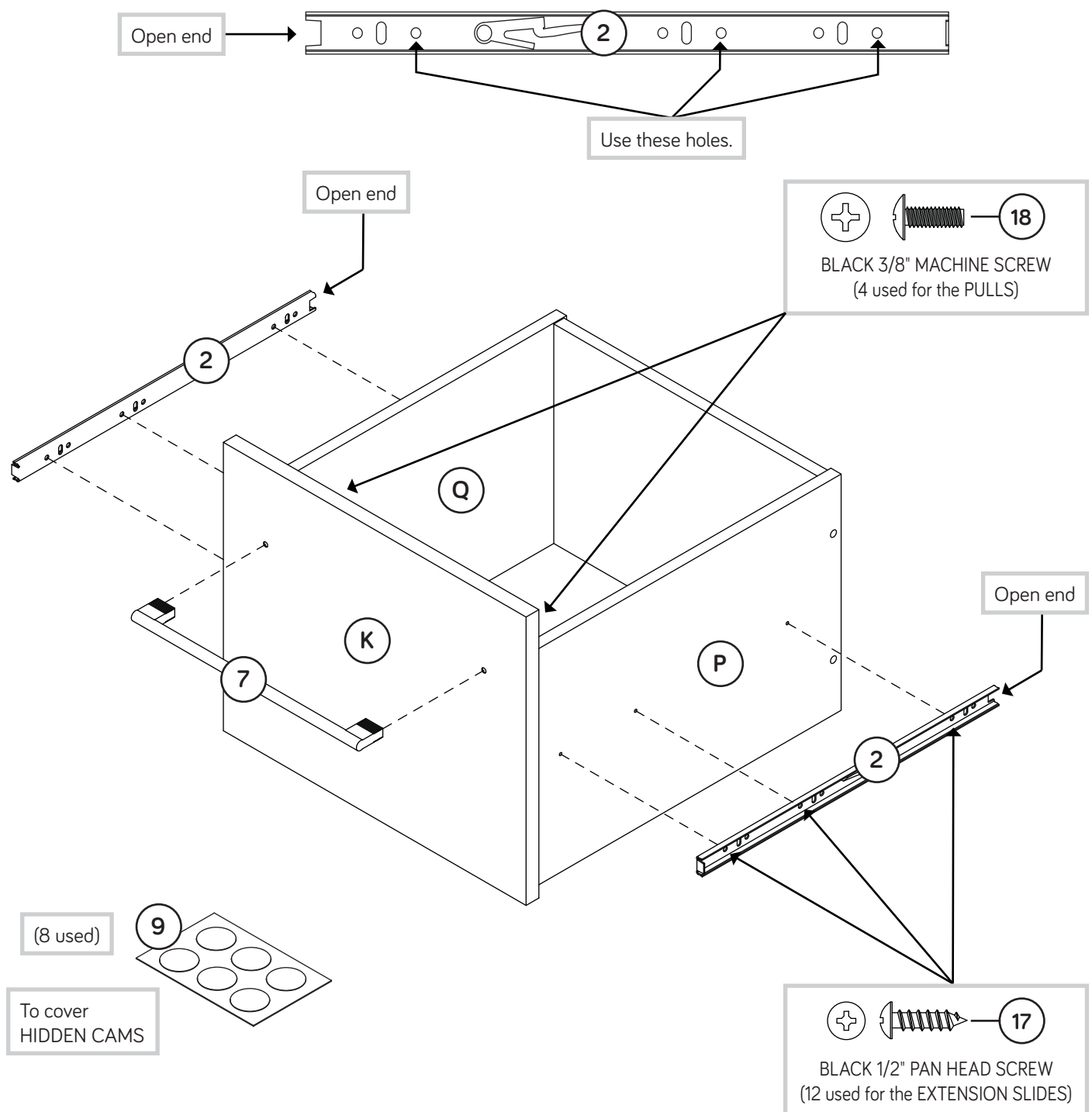

Step 15

- ✚ Push two FILE GLIDES (5) onto the LARGE DRAWER SIDES (P and Q).
- ✚ Place two FILE HANGERS (6) onto the FILE GLIDES (5) on the LARGE DRAWER SIDES (P and Q).
- ✚ Repeat this step for the other large drawer.

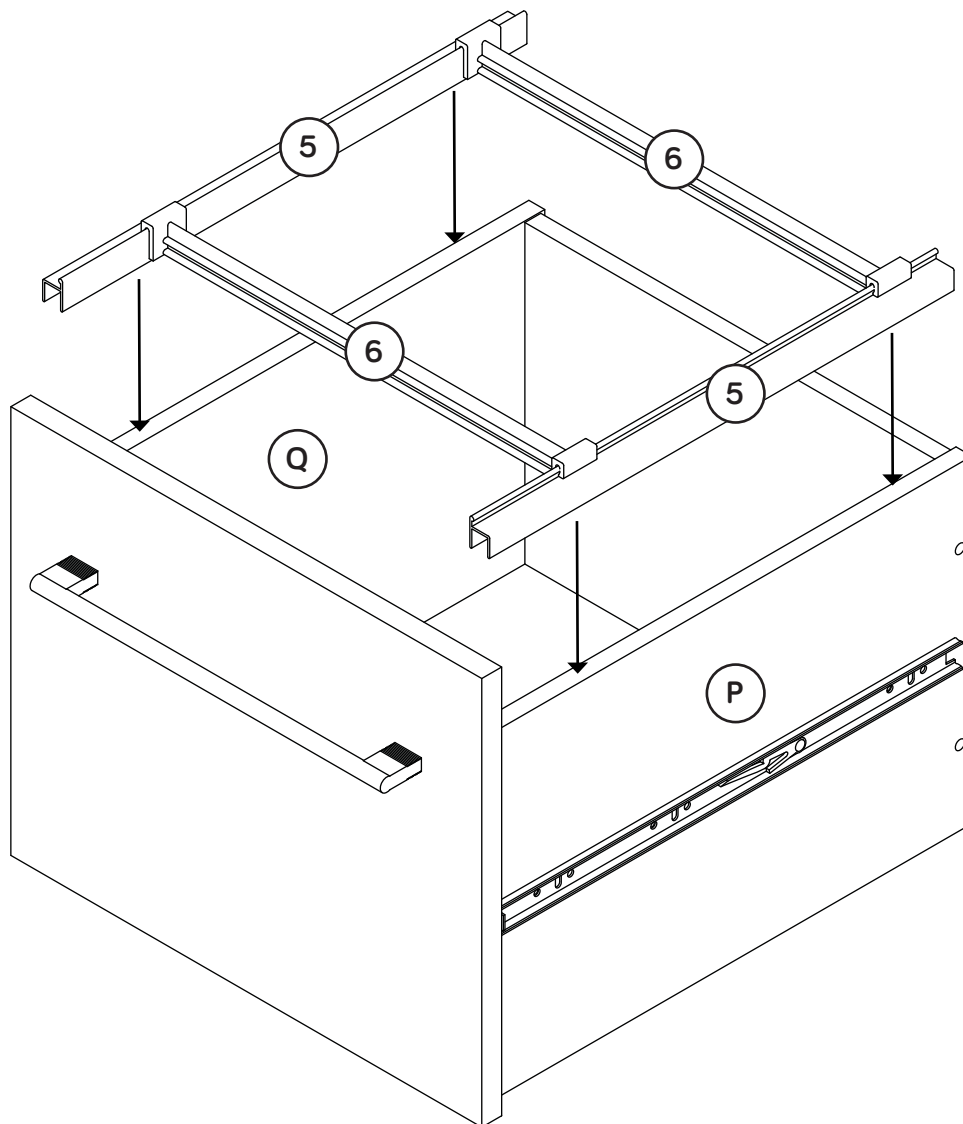

Step 16

- 🔪 Carefully stand your unit upright.
- 🔪 Peel the BUMPERS from the BUMPER CARD (10) and stick them onto the front edge of the SHELF (H).



Pro Tip: Lift with your legs. And, you know, your arms.

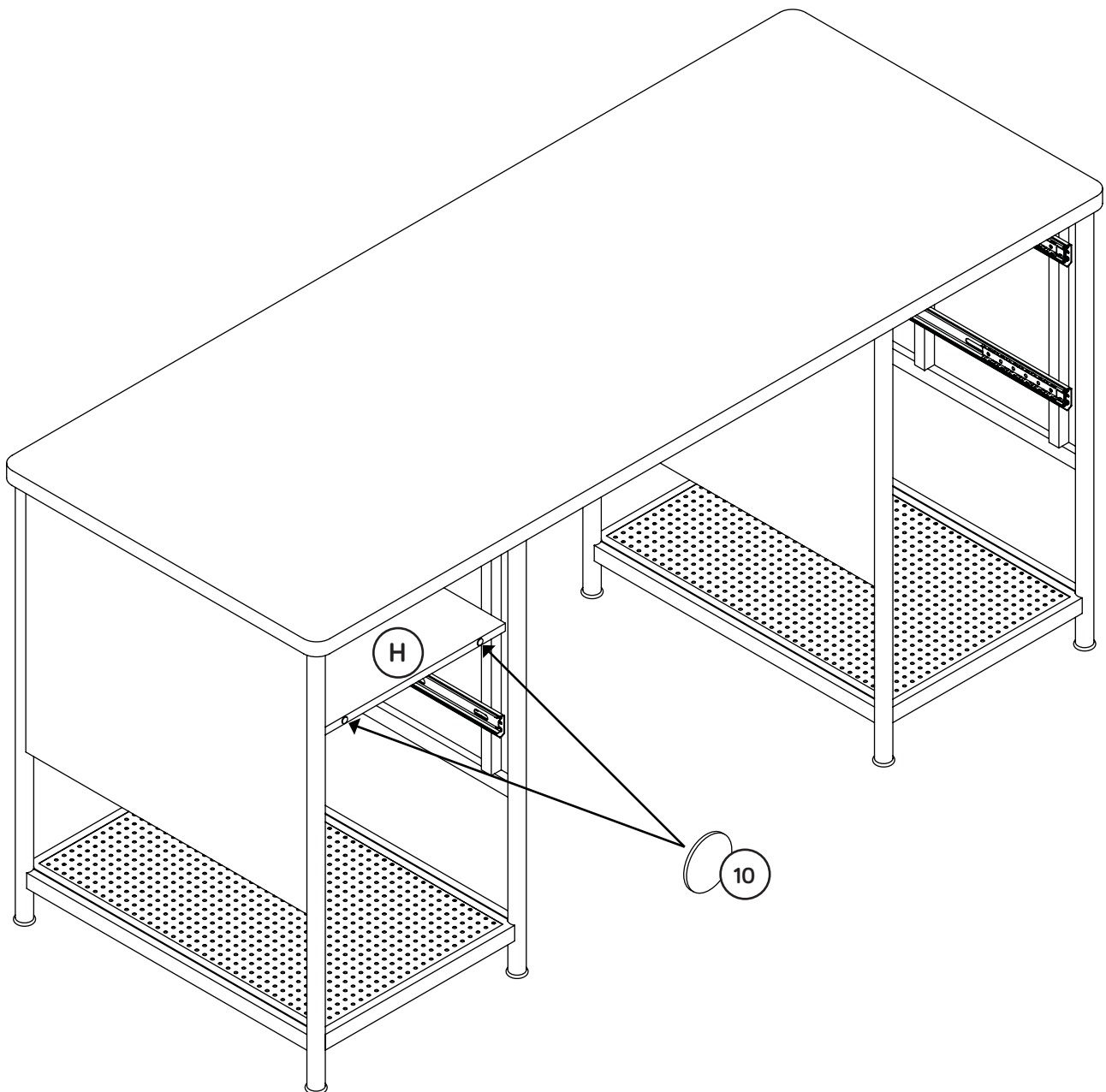

Step 17

- ✚ Position your unit in its final location.
- ✚ **NOTE:** To raise a corner of the unit, turn the ADJUSTABLE GLIDE counter-clockwise. To lower a corner, turn the ADJUSTABLE GLIDE clockwise.
- ✚ To insert the drawers into your unit, line up the EXTENSION SLIDES on the drawers with the EXTENSION RAILS on the unit and push the drawers into the unit until the drawers are fully inserted. The drawers will push in hard until they are all the way in, then they will slide in and out easier.
- ✚ **NOTE:** Please read the back pages of the instruction booklet for important safety information.
- ✚ This completes assembly. Clean with your favorite furniture polish or a damp cloth. Wipe dry.

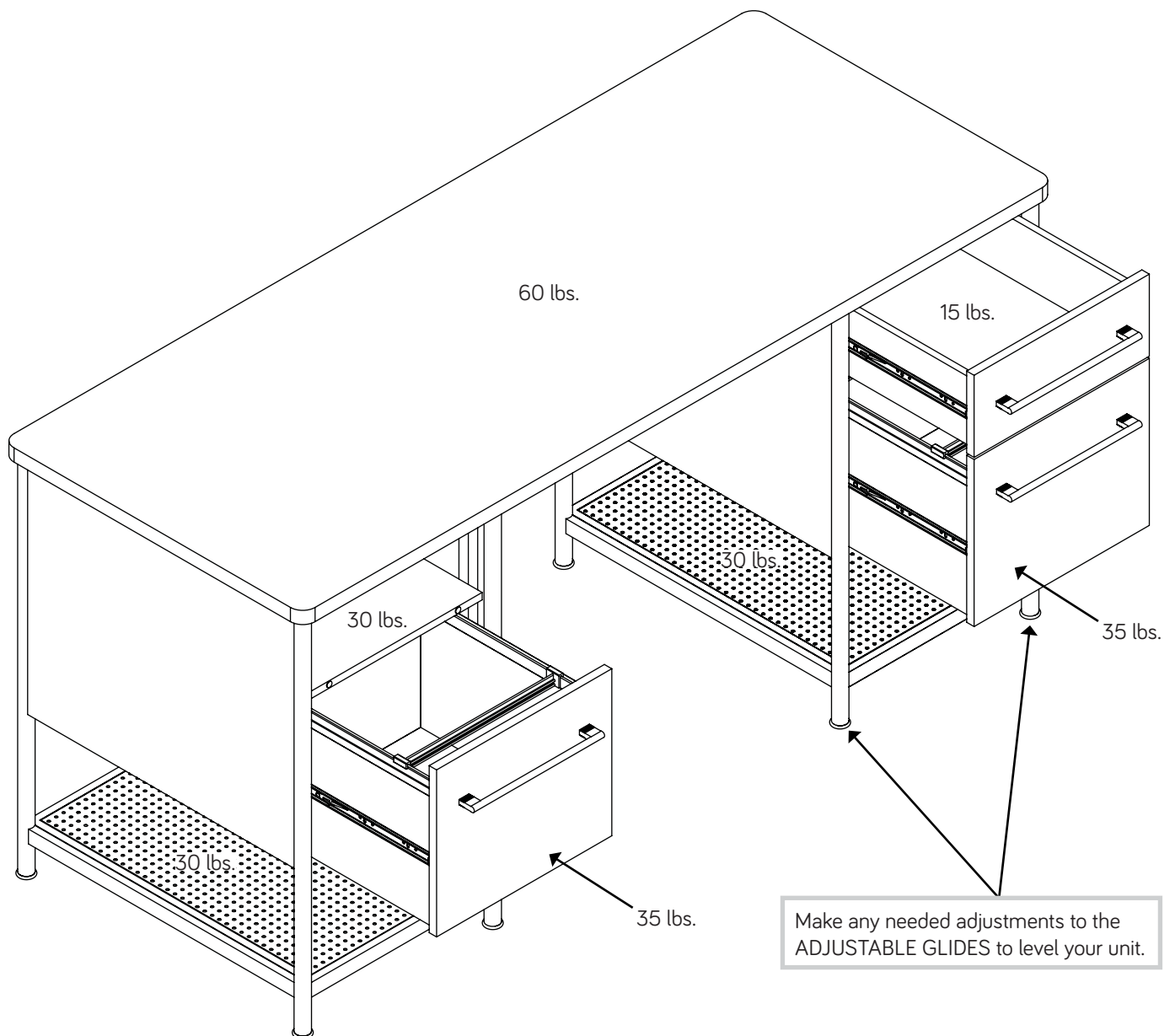

⚠ WARNING

Please use your furniture correctly and safely. Improper use can cause safety hazards, or damage to your furniture or household items. ***Carefully read the following chart.***

Look out for:	What can happen:	How to avoid the problem:
<ul style="list-style-type: none"> • Overloaded shelves or drawers. • Improper loading can cause the product to be top-heavy. 	<ul style="list-style-type: none"> • Risk of injury. • Top-heavy furniture can tip over. • Overloaded shelves and drawers can break. 	<ul style="list-style-type: none"> • Never exceed the weight limits shown in the instructions. • Work from bottom to top when loading shelves and drawers. Place the heavier items on the lower shelves or in lower drawers.
<ul style="list-style-type: none"> • Improperly moving furniture that is not designed and equipped with casters. 	<ul style="list-style-type: none"> • Furniture can tip over or break if improperly moved. • Physical injury. Furniture can be very heavy. • Breakage of tops - particularly with double pedestal furniture (drawers at both ends). 	<ul style="list-style-type: none"> • Unload shelves and drawers from top to bottom before moving the unit. • Do not push furniture, especially on a carpeted floor. Have a friend help you lift the item and set it in place. • Provide support to the center section of the top when lifting the furniture.
<ul style="list-style-type: none"> • Placing TVs on furniture items that are not designed to support a television is hazardous. 	<ul style="list-style-type: none"> • Risk of injury or death. TVs can be very heavy. Plus the weight and location of the picture tube tends to make TVs unbalanced and prone to tipping forward. 	<ul style="list-style-type: none"> • This product is not designed to support a television.