

For all your
newfangled **gadgetry**.

Boulevard Cafe L-Shaped Desk

Model 5420650

NOTE: THIS INSTRUCTION
BOOKLET CONTAINS **IMPORTANT**
SAFETY INFORMATION.

PLEASE READ AND KEEP FOR
FUTURE REFERENCE.

Table of Contents

Assembly Tools Required

Part Identification	3
Hardware Identification	4
Assembly Steps	5-38
Français	39-43
Español	44-48
Safety	49-50
Warranty	51

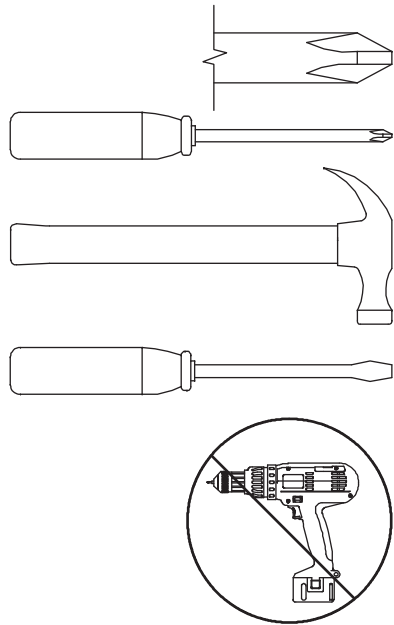

No. 2 Phillips Screwdriver
Tip Shown Actual Size

Hammer
Not actual size 😊

Straight Edge Screwdriver

Skip the power trip.
This time.

Part Identification

Now you know
our ABCs.



While not all parts are labeled, some of the parts will have a label or an inked letter on the edge to help distinguish similar parts from each other. Use this part identification to help identify similar parts.



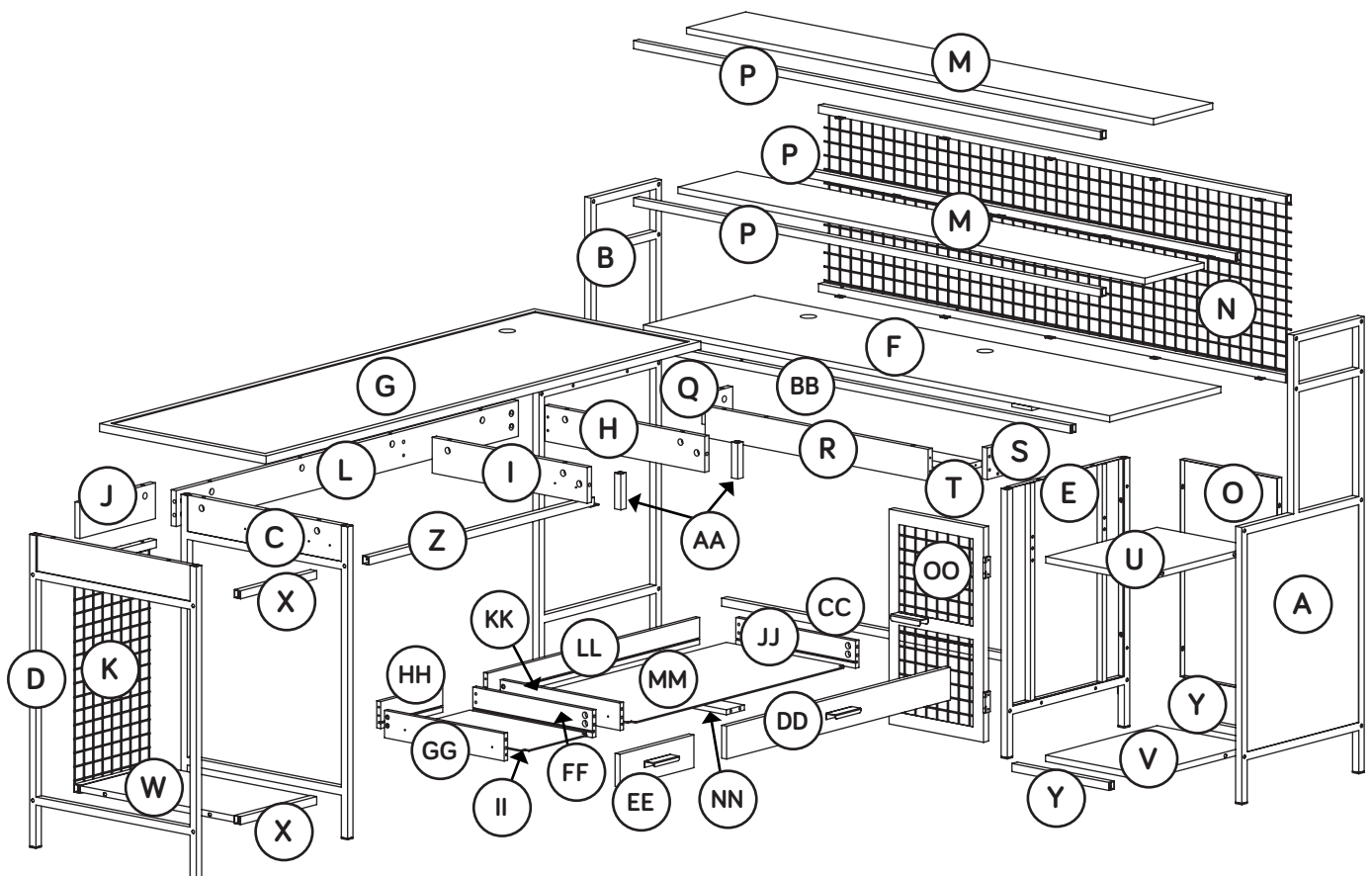





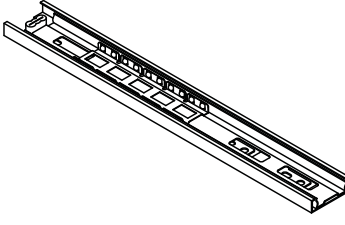
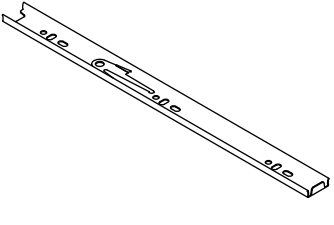

A	LARGE RIGHT END (1)	O	BACK (1)	CC	REAR RIGHT TUBE (1)
B	LARGE LEFT END (1)	P	SHELF TUBE (3)	DD	LARGE DRAWER FRONT (1)
C	SMALL RIGHT END (1)	Q	BOX LEFT END (1)	EE	SMALL DRAWER FRONT (1)
D	SMALL LEFT END (1)	R	BOX FRONT (1)	FF	SMALL RIGHT DRAWER SIDE (1)
E	LARGE UPRIGHT (1)	S	BOX RIGHT END (1)	GG	SMALL LEFT DRAWER SIDE (1)
F	SMALL TOP (1)	T	BOX BOTTOM (1)	HH	SMALL DRAWER BACK (1)
G	LARGE TOP (1)	U	SHELF (1)	II	SMALL DRAWER BOTTOM (1)
H	SMALL RIGHT UPRIGHT (1)	V	RIGHT BOTTOM (1)	JJ	LARGE RIGHT DRAWER SIDE (1)
I	SMALL LEFT UPRIGHT (1)	W	LEFT BOTTOM (1)	KK	LARGE LEFT DRAWER SIDE (1)
J	SHORT BACK (1)	X	SHORT LEFT TUBE (2)	LL	LARGE DRAWER BACK (1)
K	SMALL WIRE BACK (1)	Y	SHORT RIGHT TUBE (2)	MM	LARGE DRAWER BOTTOM (1)
L	LONG BACK (1)	Z	LONG LEFT TUBE (1)	NN	LARGE DRAWER BRACE (1)
M	LONG SHELF (2)	AA	SHORT TUBE (2)	OO	DOOR (1)
N	LARGE WIRE BACK (1)	BB	FRONT RIGHT TUBE (1)		

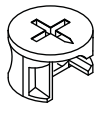

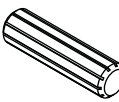
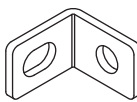
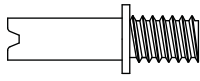
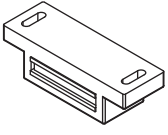
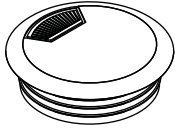
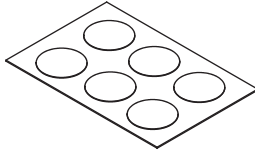
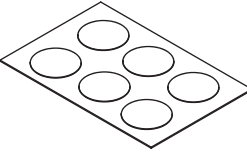
Hardware Identification

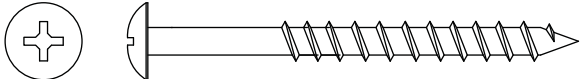
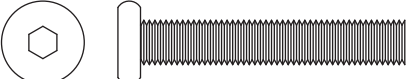
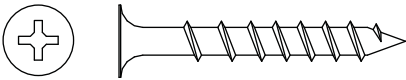
† Screws are shown actual size. You may receive extra hardware with your unit.

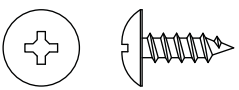
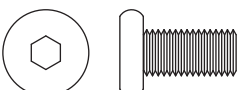
(EXTENSION SET SHOWN SEPARATED)

- | | | | | |
|--|---|---|---|--|
| <p>1 EXTENSION RAIL - 4</p>  | <p>2 EXTENSION SLIDE - 4</p>  | <p>3 LARGE HIDDEN CAM - 28</p>  | <p>4 LARGE CAM SCREW - 14</p>  | |
| <p>5 SMALL HIDDEN CAM - 10</p>  | <p>6 SMALL CAM SCREW - 24</p>  | <p>7 WOOD DOWEL - 7</p>  | <p>8 METAL BRACKET - 3</p>  | <p>9 SHELF PIN - 4</p>  |
| <p>10 MAGNETIC CATCH - 1</p>  | <p>11 GROMMET WITH CAP - 3</p>  | <p>12 BROWN APPLIQUE CARD - 1</p>  | <p>13 BLACK APPLIQUE CARD - 1</p>  | <p>14 L- WRENCH - 1</p>  |
| <p>15 BLACK 2-1/4" PAN HEAD SCREW - 4</p>  | | <p>16 BLACK 1-3/8" HEX HEAD SCREW - 25</p>  | | |
| <p>17 BLACK 1-1/2" FLAT HEAD SCREW - 21</p>  | | <p>18 BLACK 5/8" PAN HEAD SCREW - 2</p>  | | |
| <p>19 BLACK 1/2" LARGE HEAD SCREW - 30</p>  | | <p>20 BLACK 1/2" HEX HEAD SCREW - 23</p>  | | |
| <p>21 BLACK 1/2" FLAT HEAD SCREW - 4</p>  | | <p>22 BLACK 1/2" PAN HEAD SCREW - 24</p>  | | |

Step 2

- Turn fourteen LARGE CAM SCREWS (4) into the exact holes shown in the TOPS (F and G), SMALL RIGHT UPRIGHT (H), and BOX FRONT (R).
- Push ten SMALL HIDDEN CAMS (5) into the DRAWER SIDES (FF, GG, JJ, and KK) and LARGE DRAWER BRACE (NN).

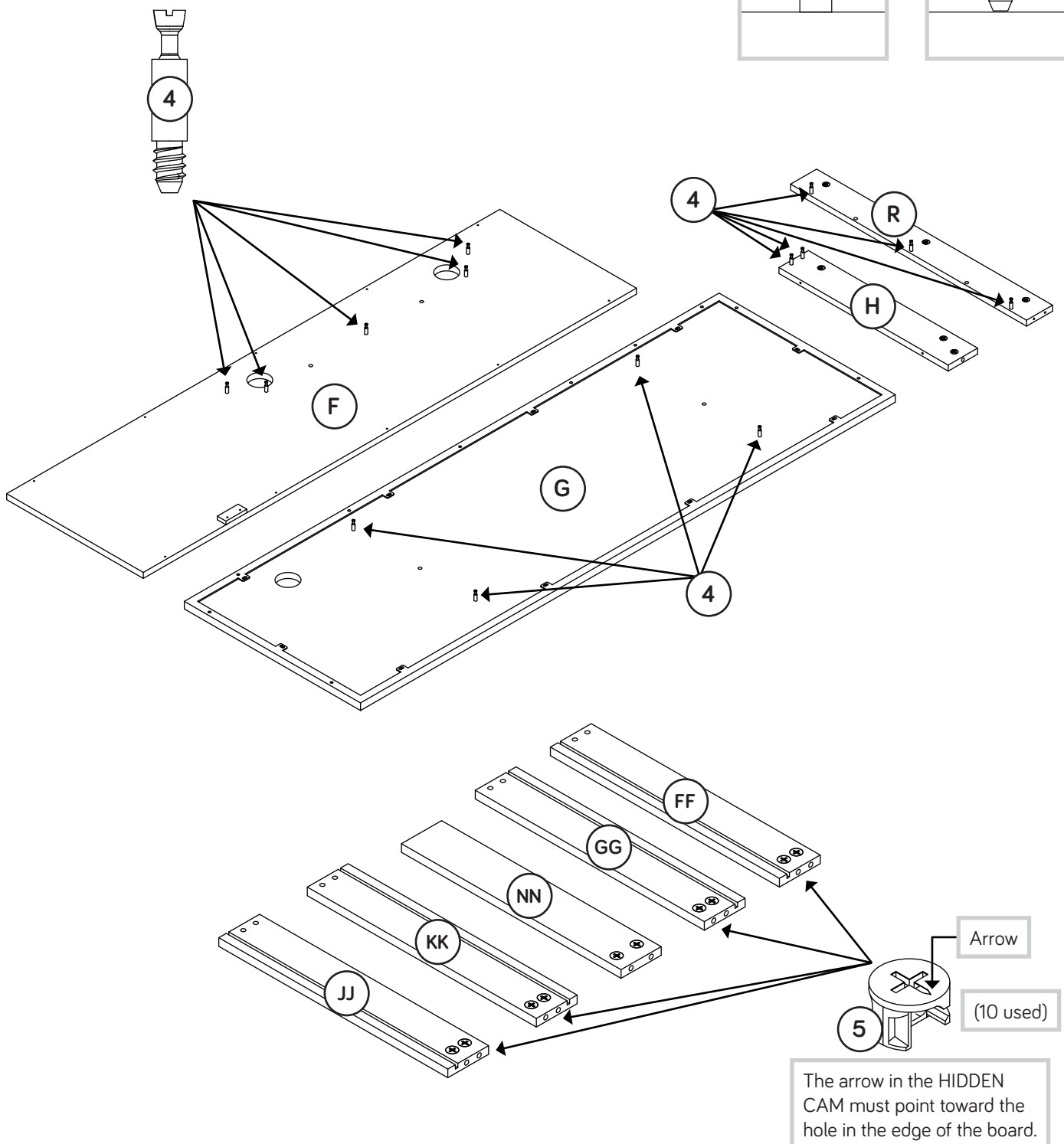
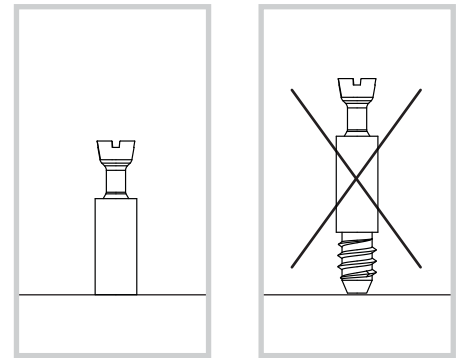

Step 3

Turn twenty-four SMALL CAM SCREWS (6) into the exact holes shown in the SMALL RIGHT END (C), LARGE TOP (G), SHORT TUBES (AA), and DRAWER FRONTS (DD and EE).

NOTE: The SMALL CAM SCREWS are turned into the metal portion of the part.

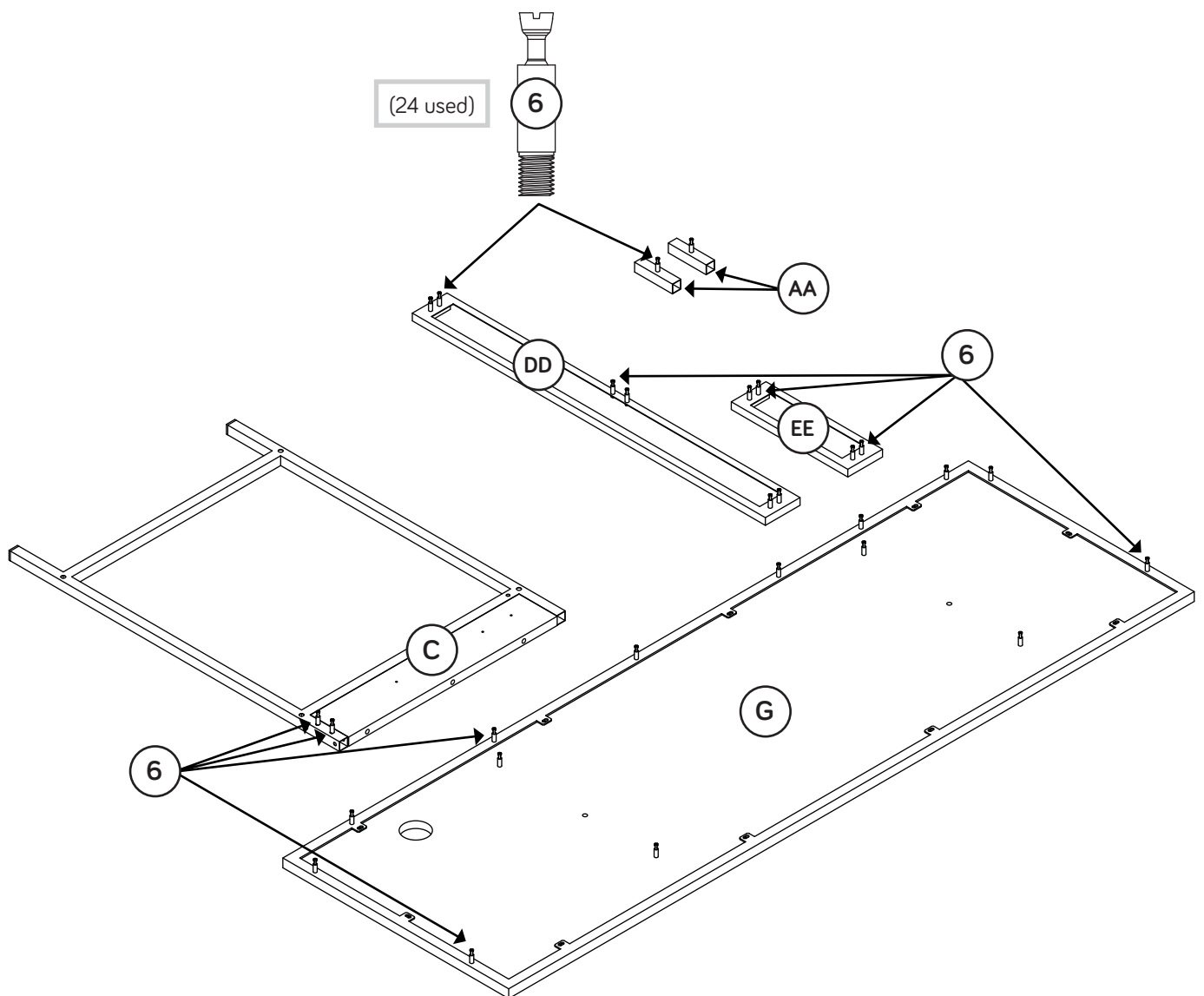
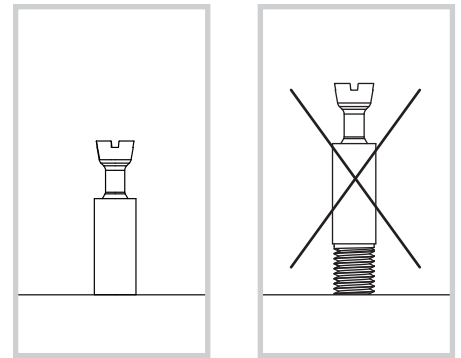

Step 4

- Fasten the LARGE LEFT END (B) to the LARGE WIRE BACK (N). Tighten two BLACK 1-3/8" HEX HEAD SCREWS (16) using the L-WRENCH (14).



Just think. The sooner you do this, the sooner you do something else.

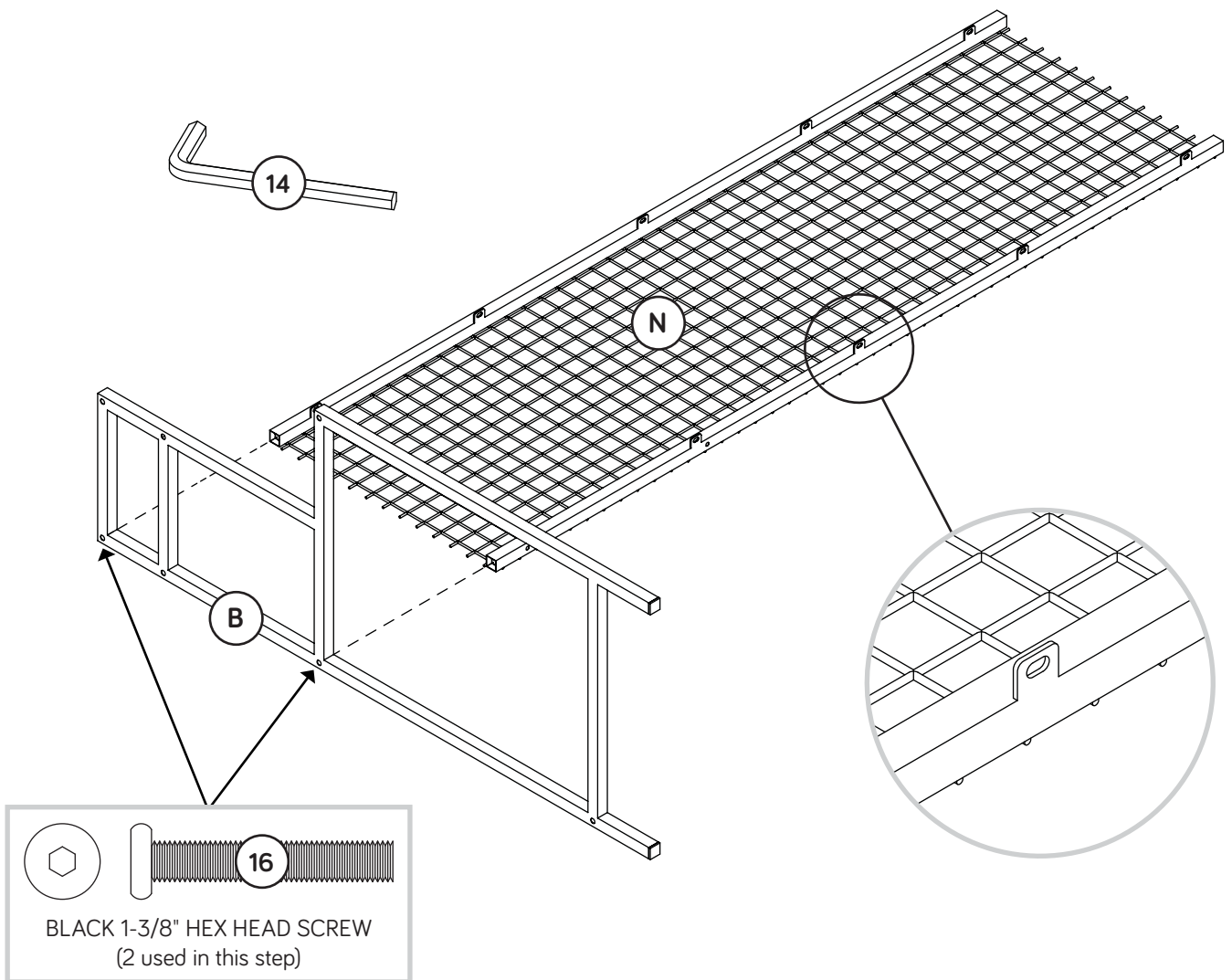

Step 5

- 🔩 **NOTE:** Be sure to keep SCREWS (19) separate from SCREWS (22). Do not confuse these SCREWS.
- 🔩 Fasten the SHELF TUBES (P) to the LONG SHELVES (M). Use fifteen BLACK 1/2" LARGE HEAD SCREWS (19).
- 🔩 **NOTE:** Be sure SHELF TUBES wrap around the edges of the LONG SHELVES.

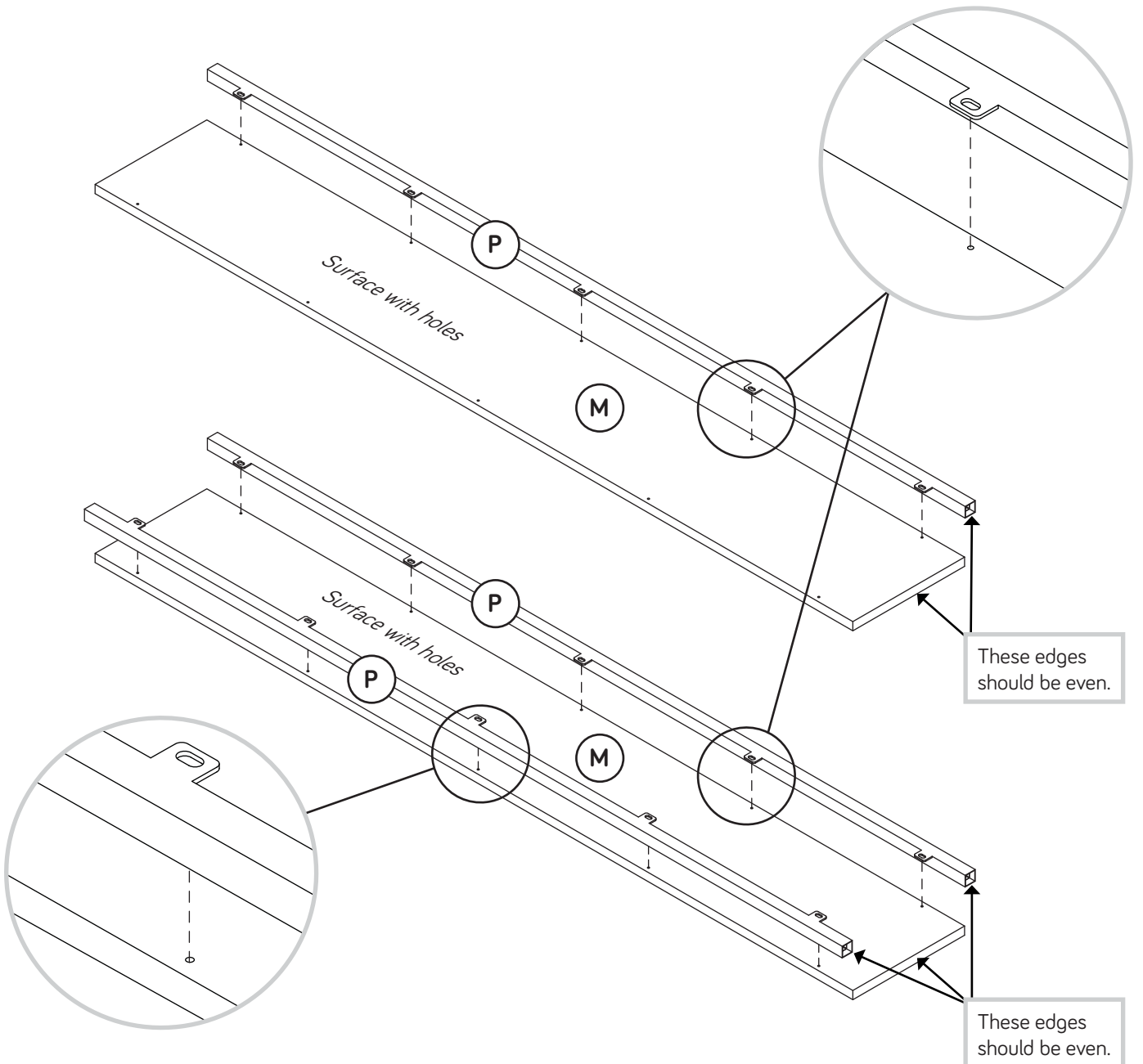
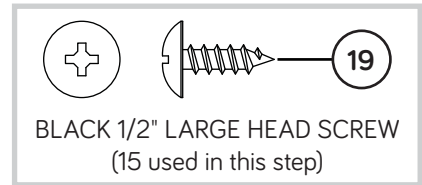

Step 6

- Fasten the LONG SHELF (M) with one SHELF TUBE (P) to the LEFT END (B). Tighten one BLACK 1-3/8" HEX HEAD SCREW (16) using the L-WRENCH (14).
- Fasten the LONG SHELF (M) to the LARGE WIRE BACK (N). Use five BLACK 1/2" LARGE HEAD SCREWS (19).

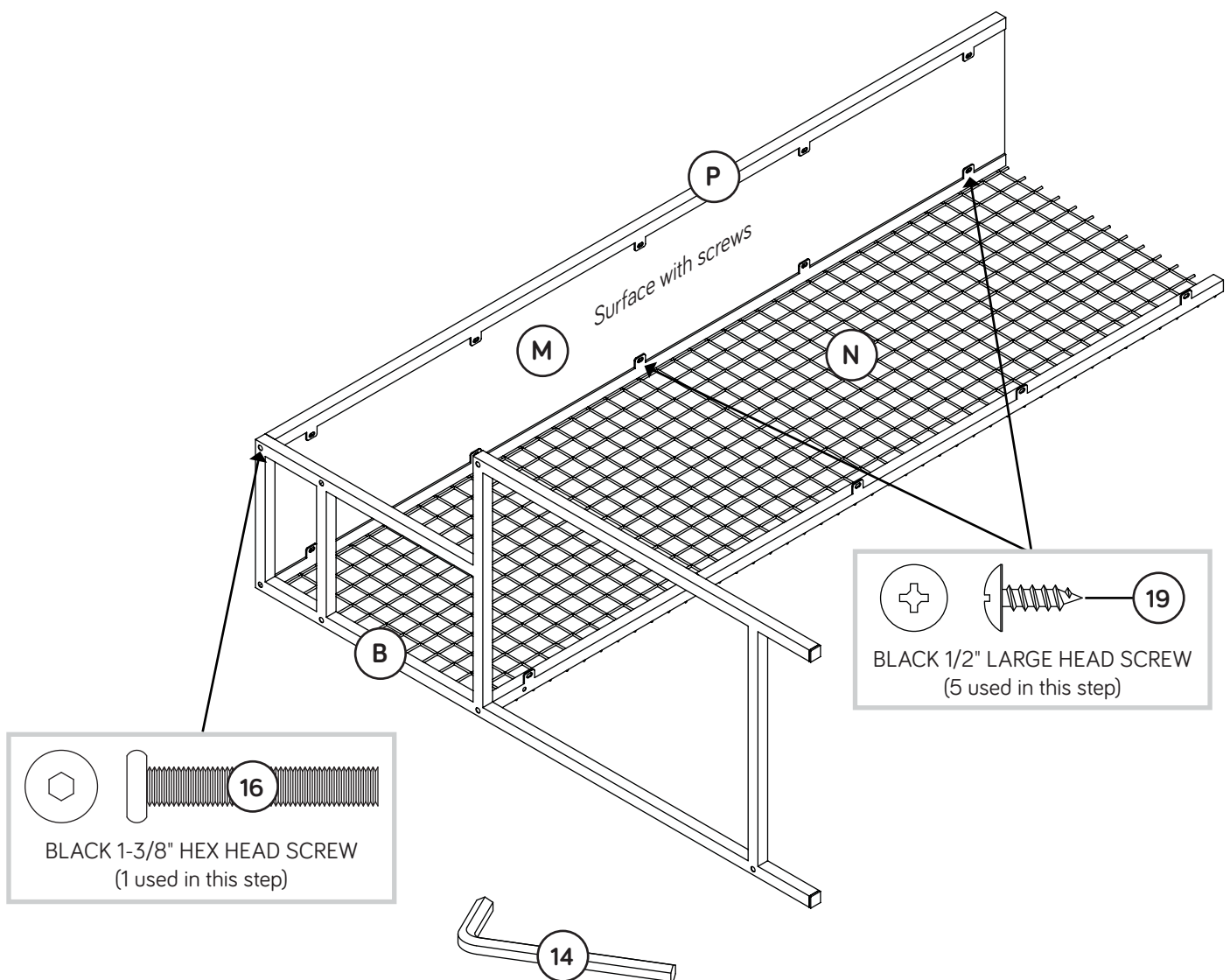

Step 7

- Fasten the LONG SHELF (M) with two SHELF TUBES to the LEFT END (B). Tighten two BLACK 1-3/8" HEX HEAD SCREWS (16) using the L-WRENCH (14).

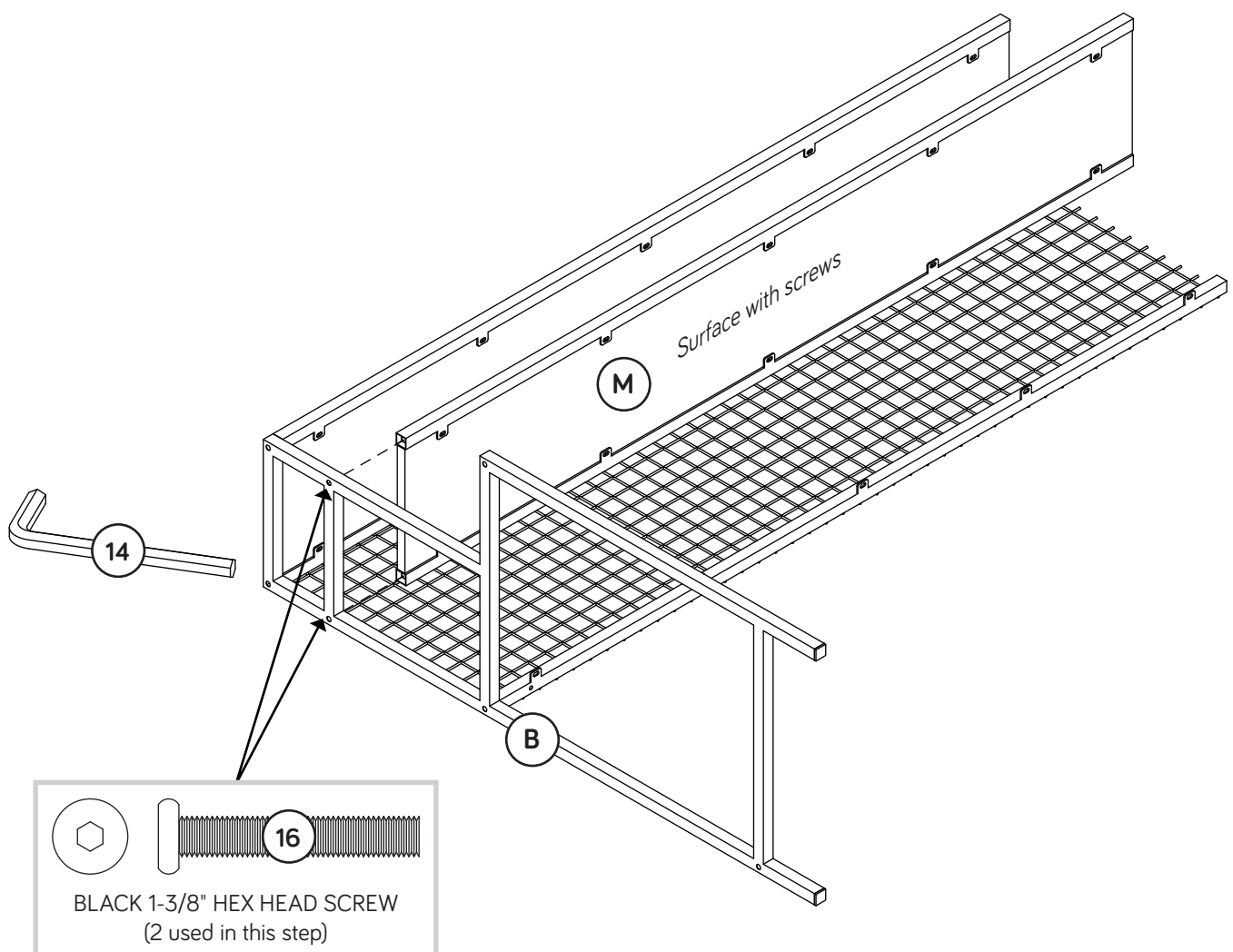

Step 8

Fasten the FRONT RIGHT TUBE (BB) to the SMALL TOP (F).
Use five BLACK 1/2" LARGE HEAD SCREWS (19).

NOTE: Be sure the FRONT RIGHT TUBE wraps around the edge of the SMALL TOP.

Fasten the MAGNETIC CATCH (10) to the block on the SMALL TOP (F) exactly as shown. Use two BLACK 5/8" PAN HEAD SCREWS (18).

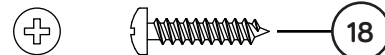

BLACK 5/8" PAN HEAD SCREW
(2 used for the MAGNETIC CATCH)

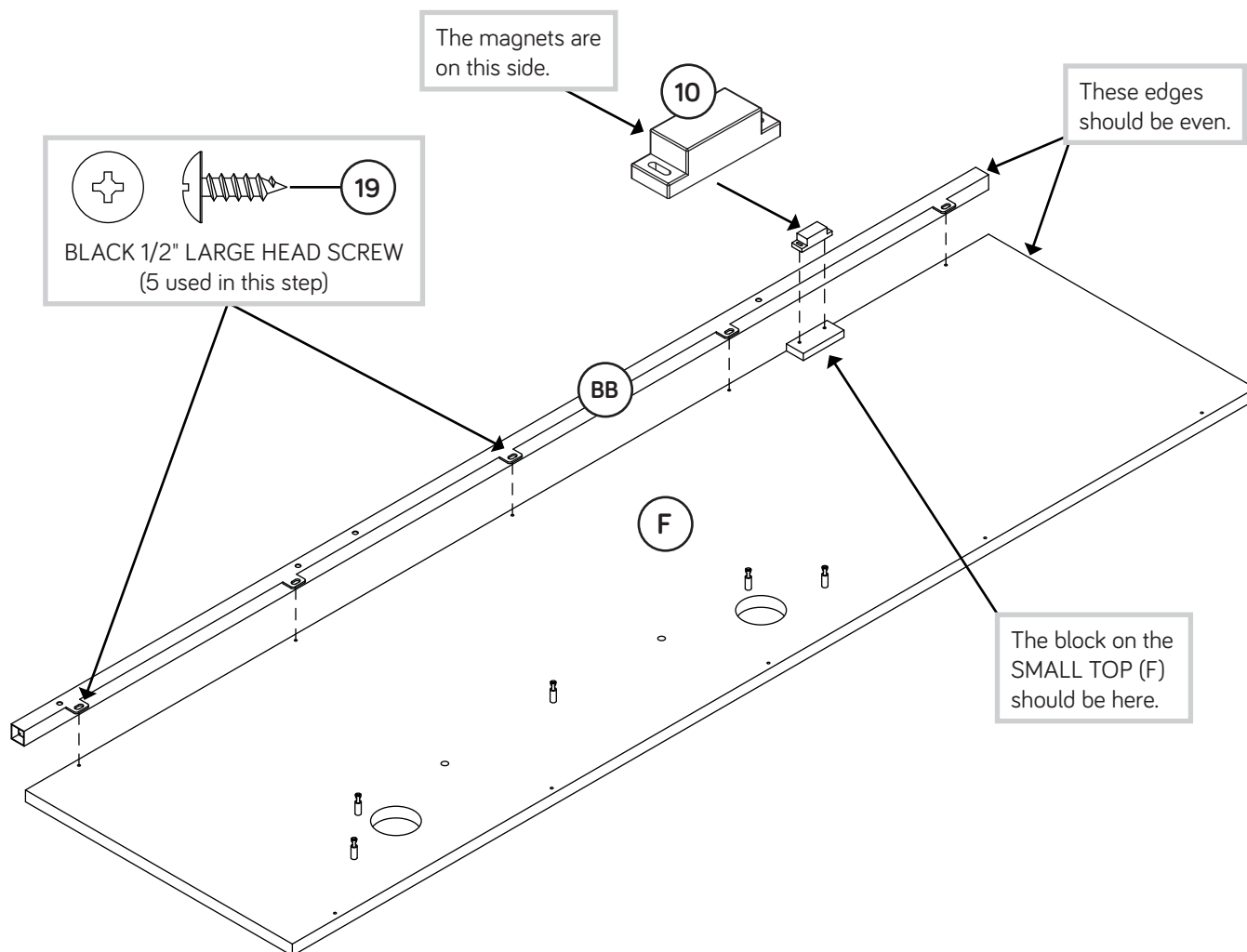

Step 9

- ✚ Fasten the BOX ENDS (Q and S) to the BOX FRONT (R). Use four BLACK 1-1/2" FLAT HEAD SCREWS (17).
- ✚ Insert two WOOD DOWELS (7) into the SMALL TOP (F).
- ✚ Fasten the BOX FRONT (R) and BOX ENDS (Q and S) to the SMALL TOP (F). Tighten five HIDDEN CAMS.
- ✚ **NOTE:** Be sure the WOOD DOWELS in the SMALL TOP insert into the BOX FRONT.

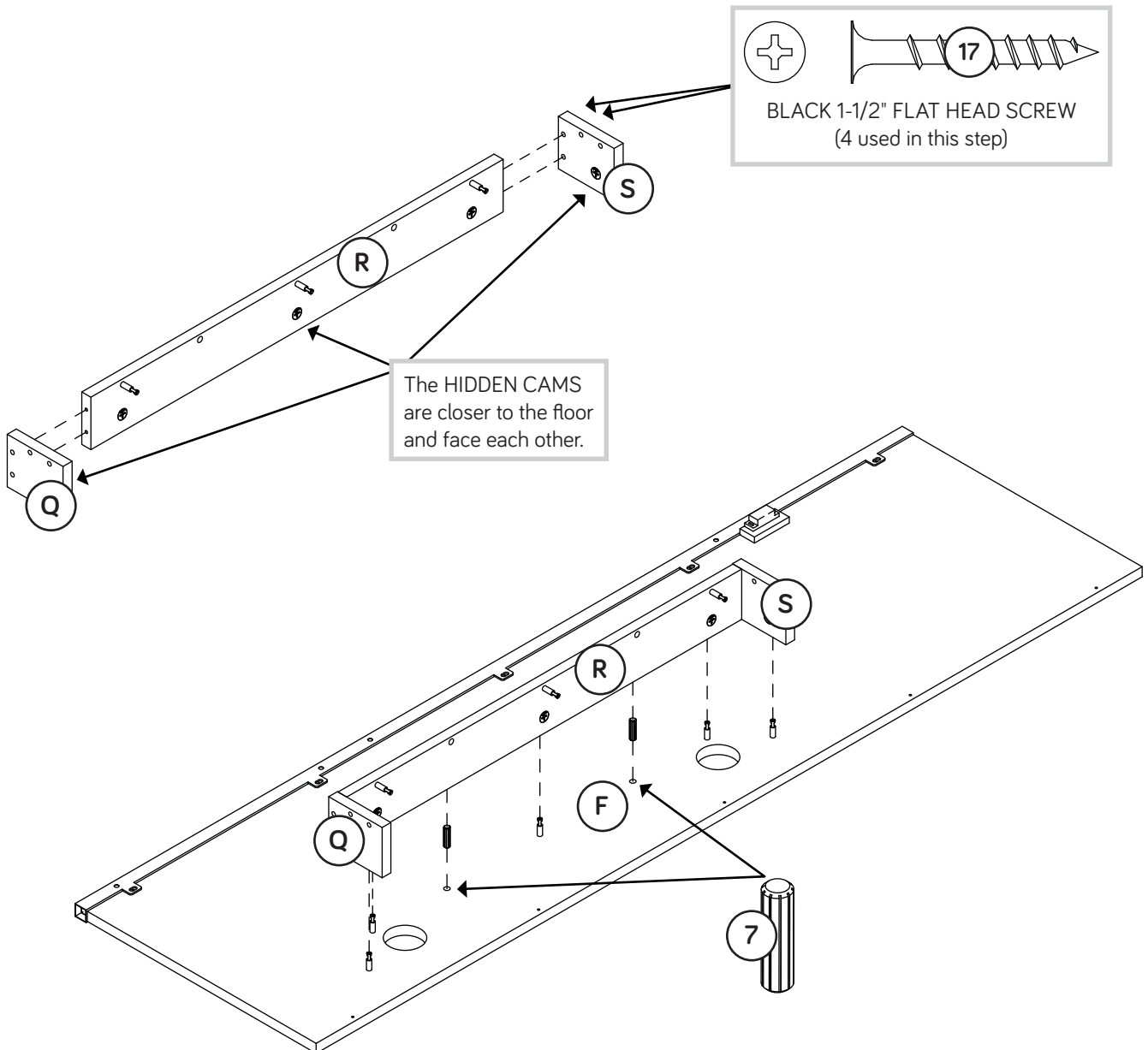
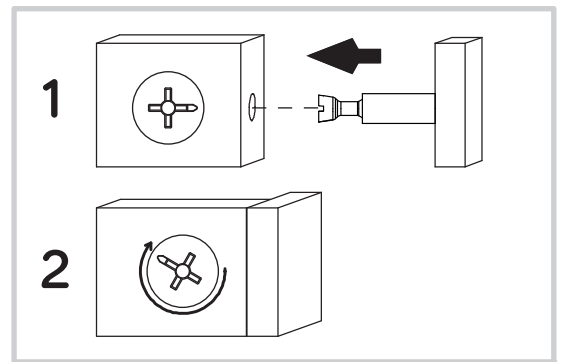

Step 10

- ✚ Insert two WOOD DOWELS (7) into the BOX FRONT (R).
- ✚ Fasten the BOX BOTTOM (T) to the BOX FRONT (R).
Tighten three HIDDEN CAMS.
- ✚ **NOTE:** Be sure the WOOD DOWELS in the BOX FRONT insert into the BOX BOTTOM.
- ✚ Fasten the BOX ENDS (Q and S) to the BOX BOTTOM (T).
Use four BLACK 1-1/2" FLAT HEAD SCREWS (17).

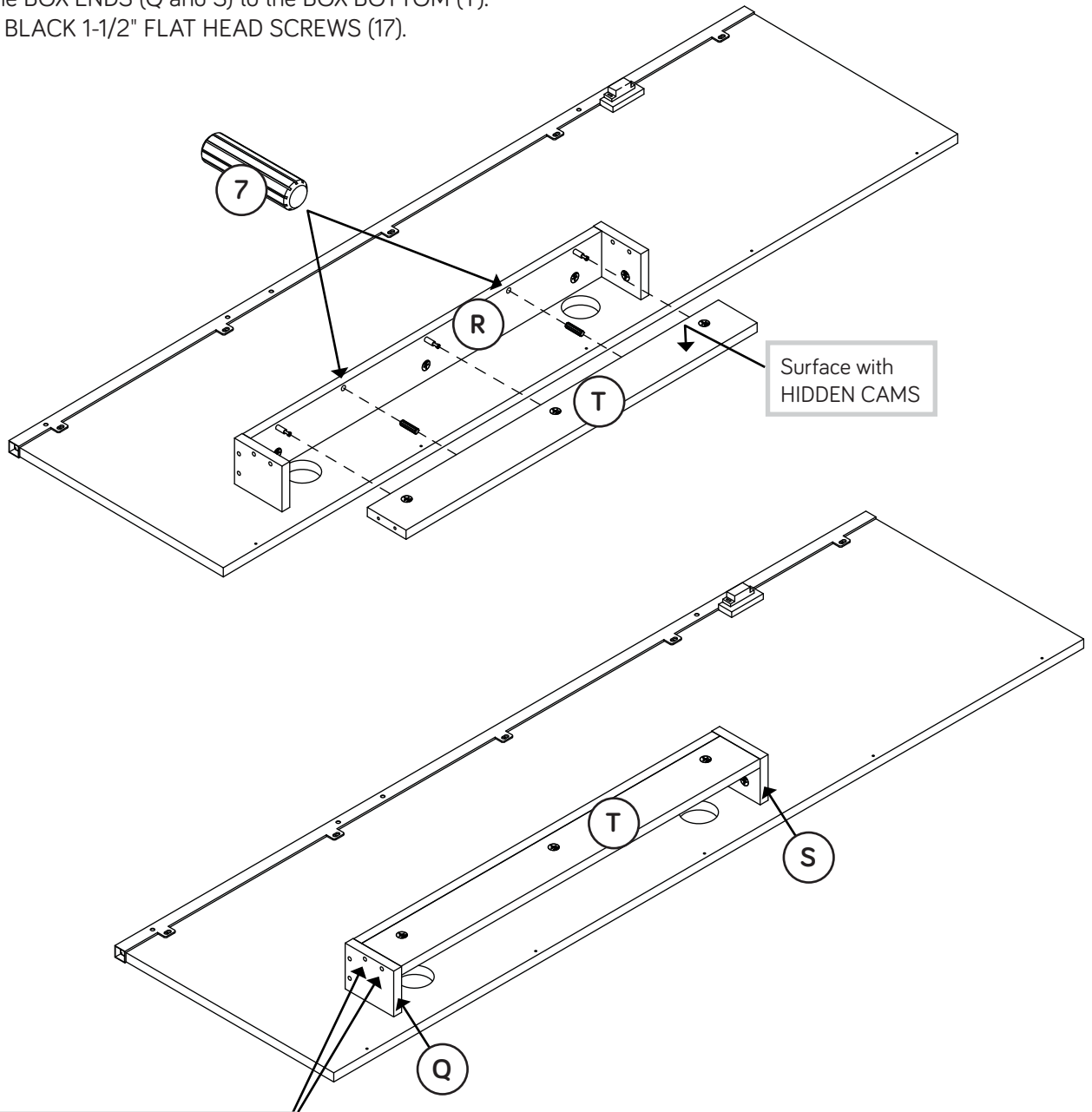

BLACK 1-1/2" FLAT HEAD SCREW
(4 used in this step)

Step 11

- Fasten the SMALL TOP (F) to the LEFT END (B). Tighten one BLACK 1-3/8" HEX HEAD SCREW (16) using the L-WRENCH (14).
- Fasten the SMALL TOP (F) to the LARGE WIRE BACK (N). Use five BLACK 1/2" LARGE HEAD SCREWS (19).

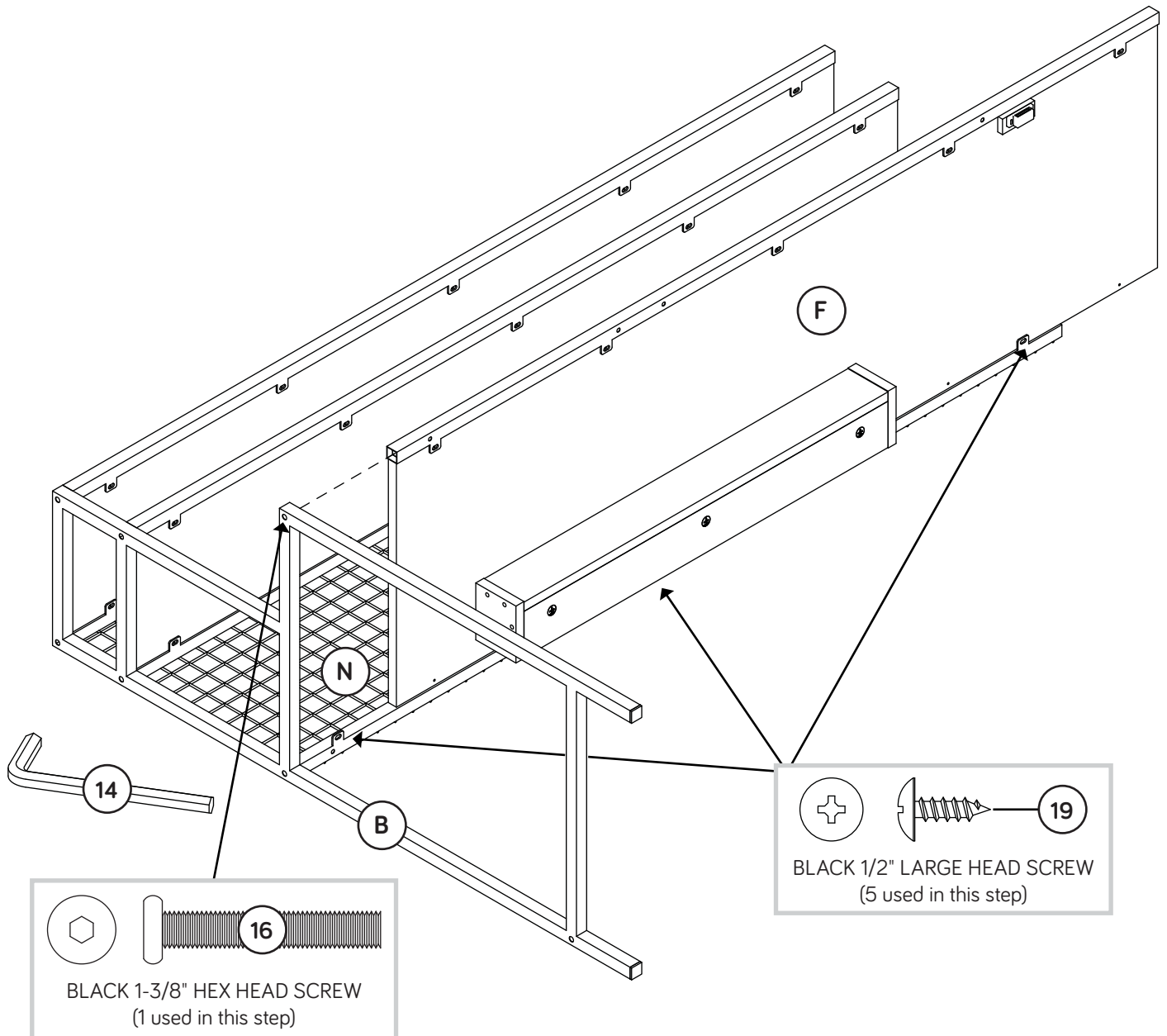

Step 12

🔩 **NOTE:** Do not completely tighten the SCREWS in this step.

🔩 Fasten the BACK (O) and RIGHT BOTTOM (V) to the LARGE RIGHT END (A). Tighten five BLACK 1/2" HEX HEAD SCREWS (20) using the L-WRENCH (14).



Don't worry. It isn't Rome. This can be built in a day.

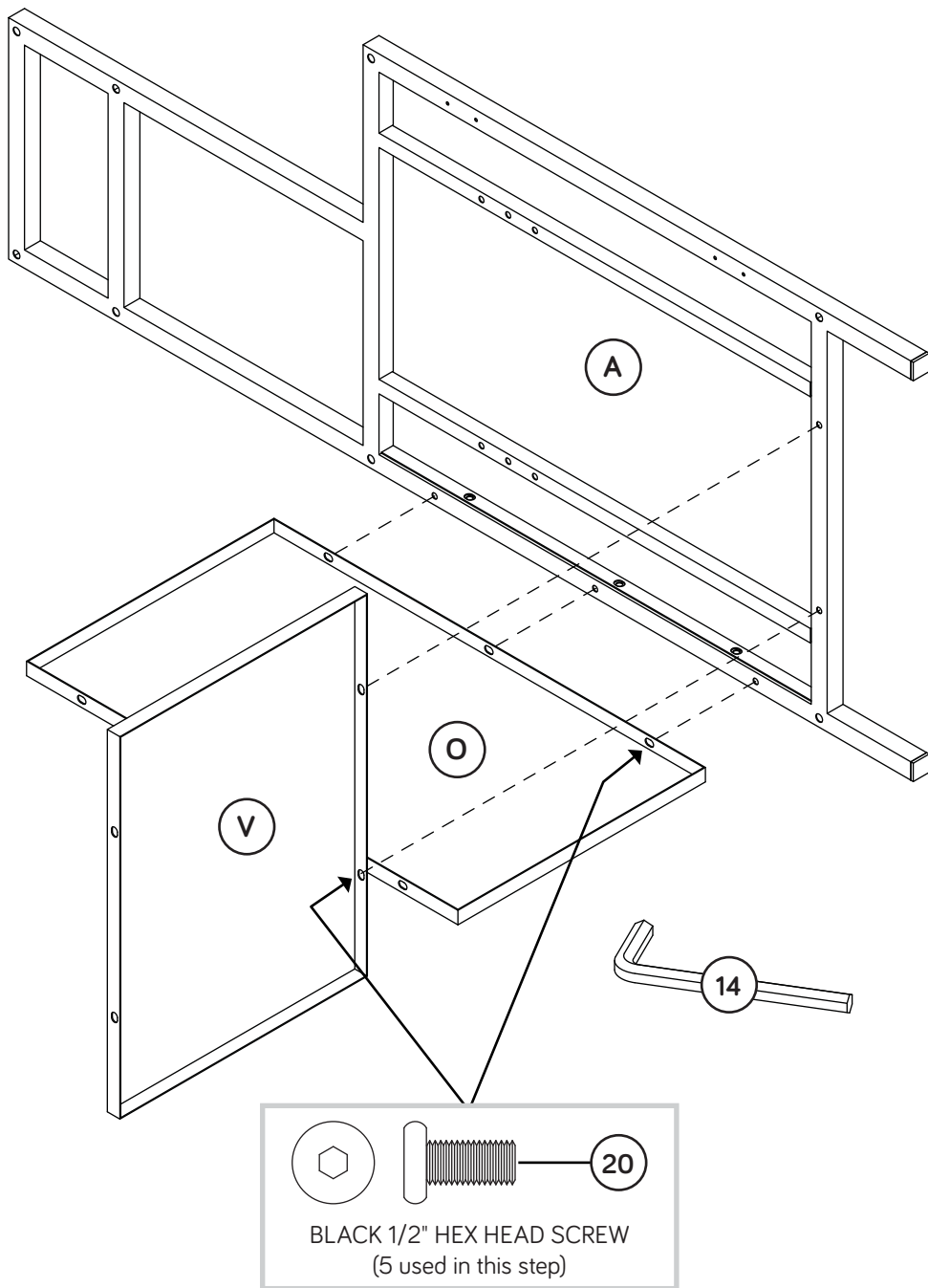

Step 13

- 🔩 **NOTE:** Do not completely tighten the SCREWS in this step.
- 🔩 Fasten the SHORT RIGHT TUBES (Y) to the RIGHT END (A).
Tighten two BLACK 1-3/8" HEX HEAD SCREWS (16) using the L-WRENCH (14).

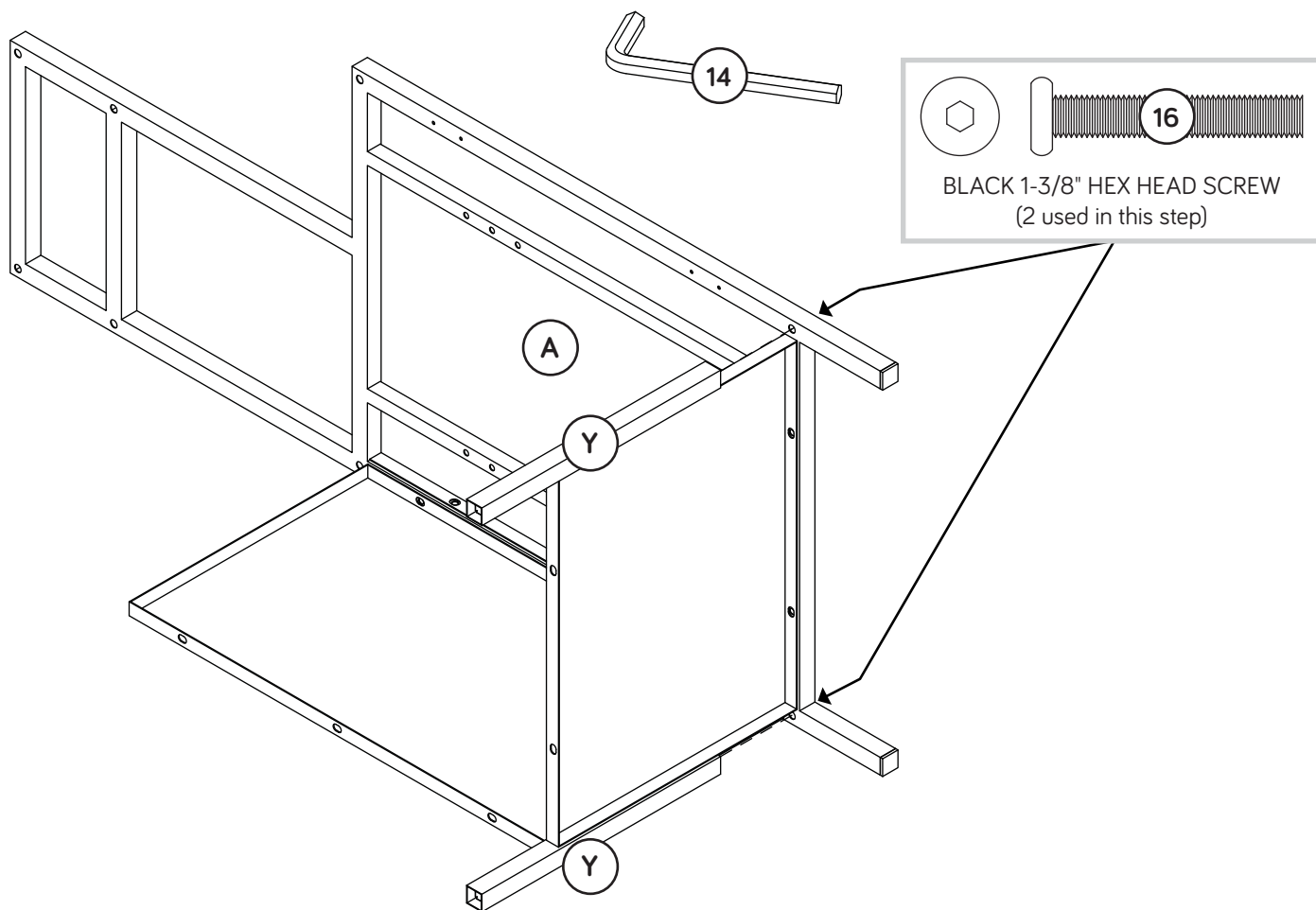

Step 14

- ✚ Fasten the LARGE UPRIGHT (E) to the BACK (O). Tighten three BLACK 1/2" HEX HEAD SCREWS (20) using the L-Wrench (14).
- ✚ Fasten the LARGE UPRIGHT (E) to the RIGHT BOTTOM (V). Tighten two BLACK 1/2" HEX HEAD SCREWS (20) using the L-Wrench (14).
- ✚ Fasten the LARGE UPRIGHT (E) to the SHORT RIGHT TUBES (Y). Tighten two BLACK 1-3/8" HEX HEAD SCREWS (16) using the L-Wrench (14).
- ✚ NOTE: Now, completely tighten all of the SCREWS from Steps 12-14.

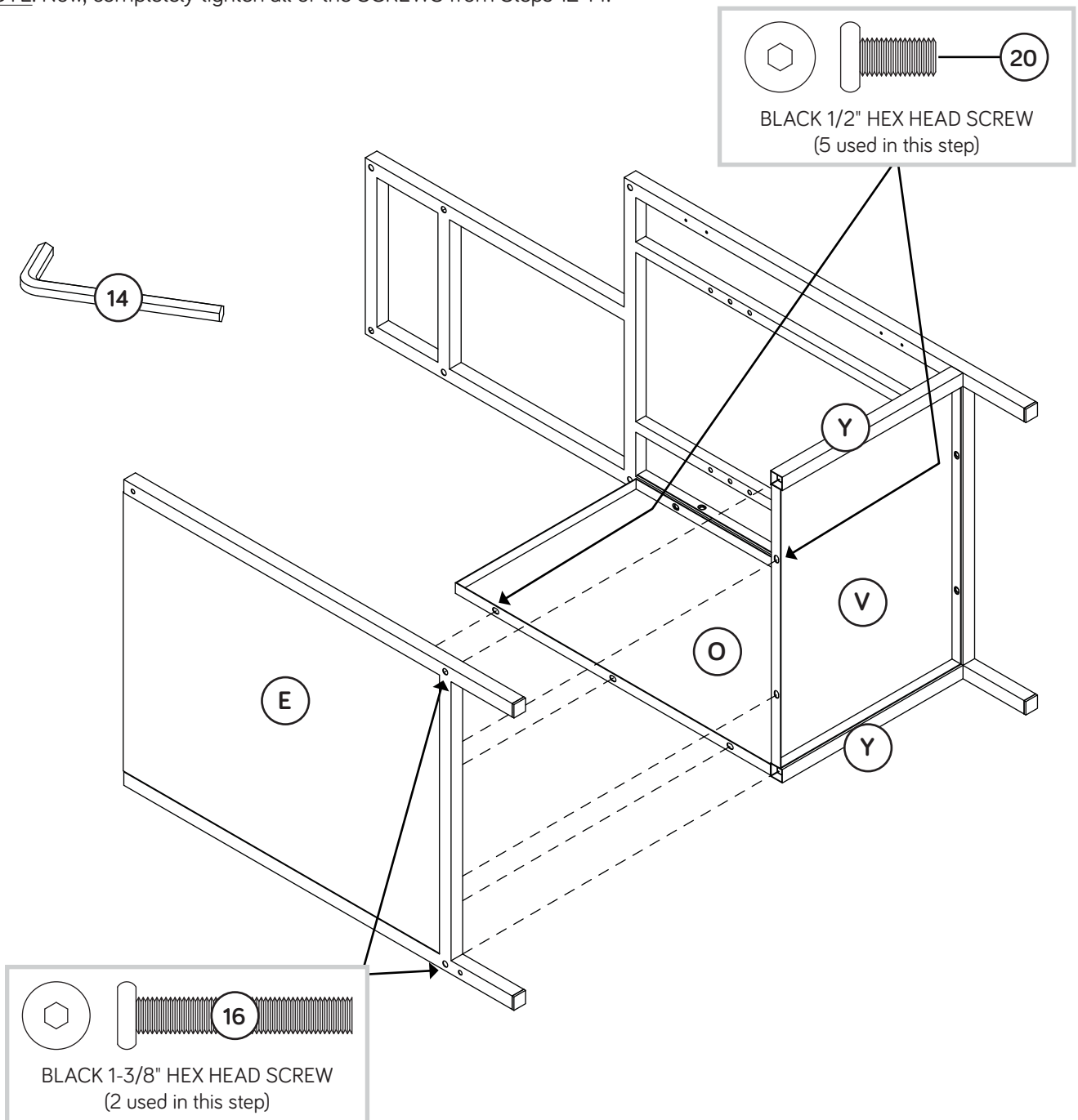

Step 15

- 🔩 **NOTE:** Start all of the SCREWS before completely tightening any of them.
- 🔩 Fasten the LARGE RIGHT END (A) to the SMALL TOP (F) and LONG SHELVES (M). Tighten six BLACK 1-3/8" HEX HEAD SCREWS (16) using the L-Wrench (14).

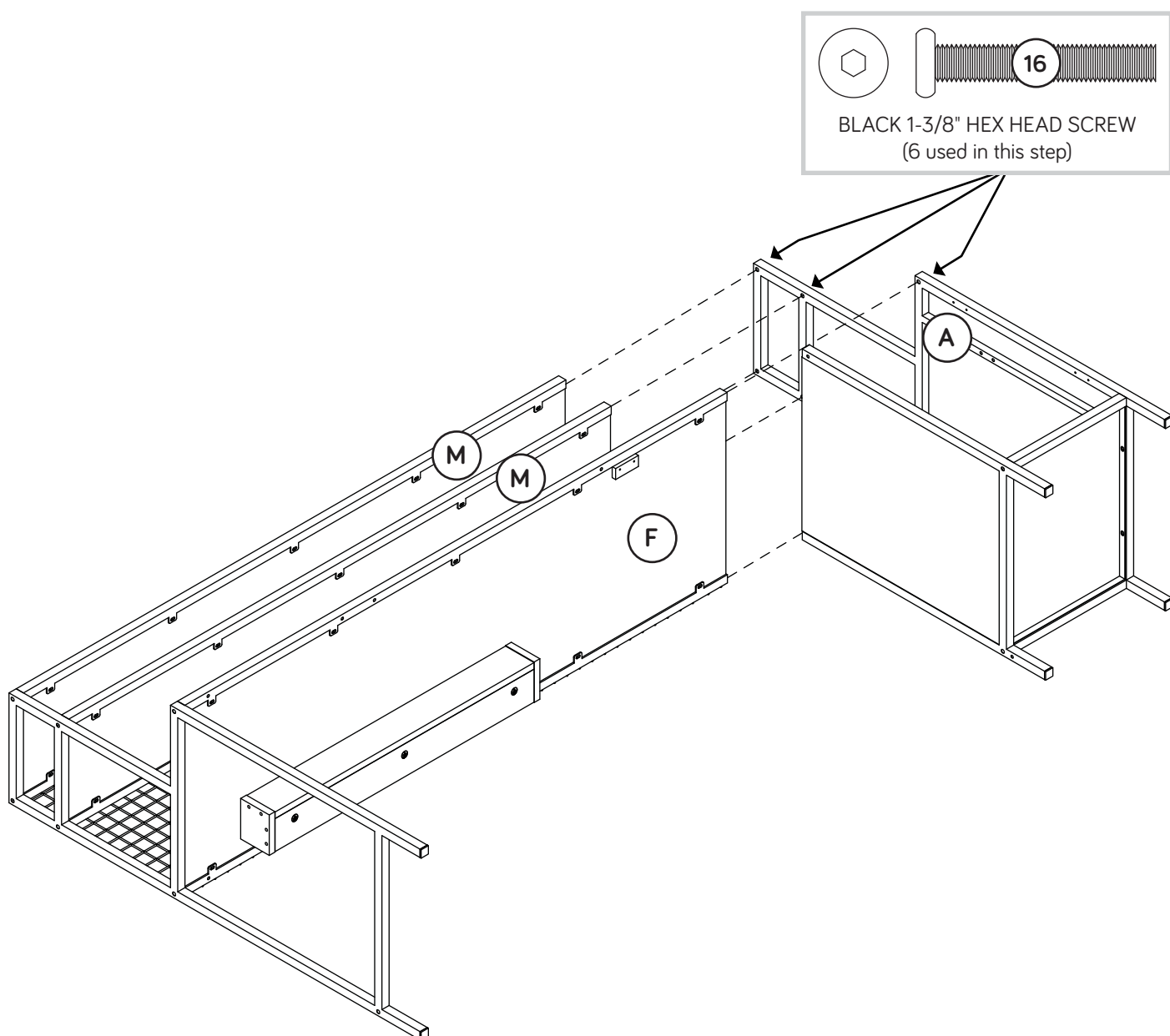

Step 16

- Fasten the REAR RIGHT TUBE (CC) to the LARGE LEFT END (B). Tighten one BLACK 1-3/8" HEX HEAD SCREW (16) using the L-Wrench (14).
- Fasten one METAL BRACKET (8) to the LARGE UPRIGHT (E) and REAR RIGHT TUBE (CC) exactly as shown. Tighten two BLACK 1/2" HEX HEAD SCREWS (20) using the L-Wrench (14).
- Fasten one METAL BRACKET (8) to the LARGE UPRIGHT (E) and FRONT RIGHT TUBE (BB) on the SMALL TOP (F) exactly as shown. Tighten two BLACK 1/2" HEX HEAD SCREWS (20) using the L-Wrench (14).

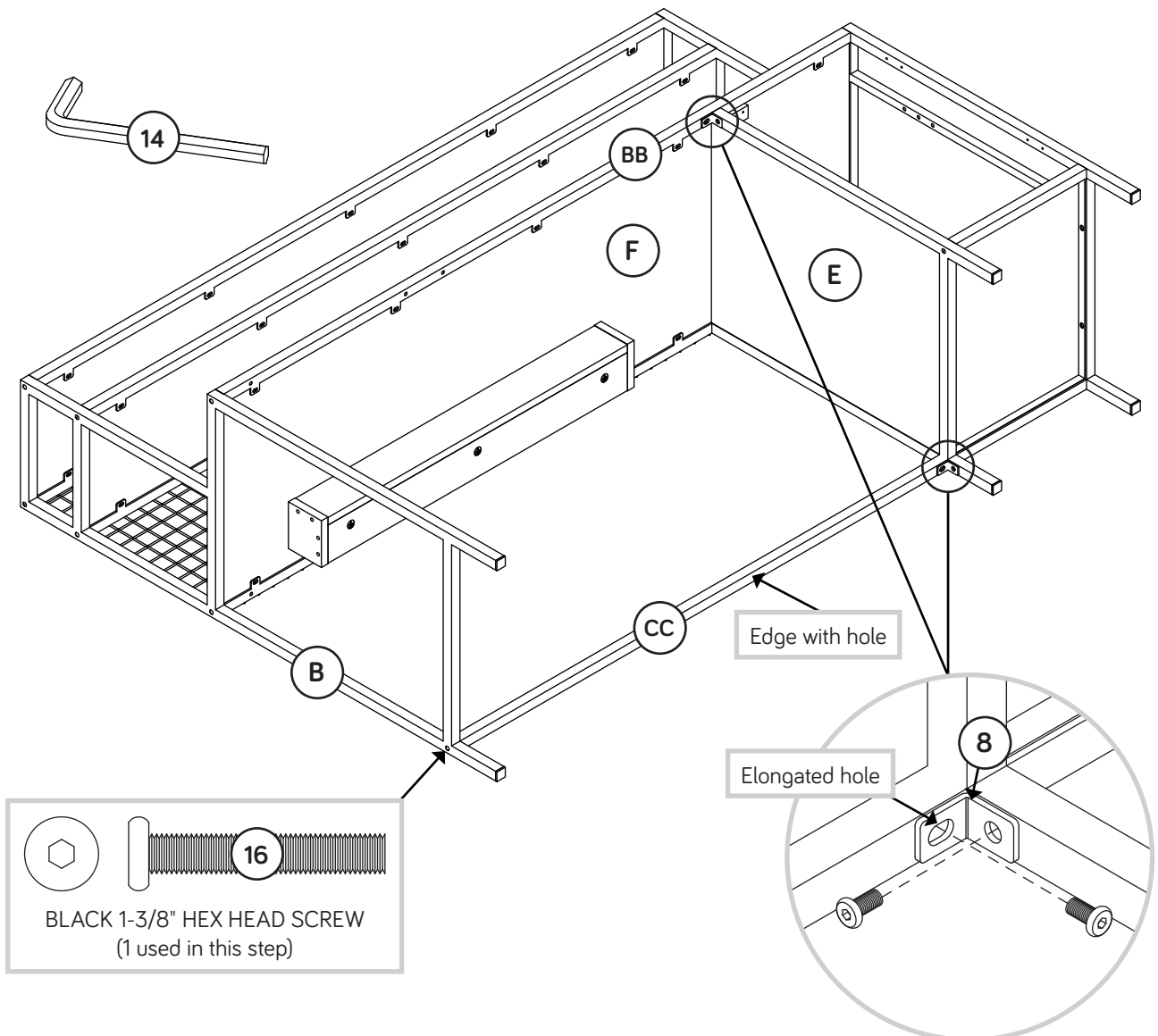
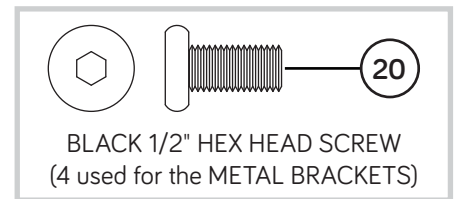

Step 17

- ✚ Separate the EXTENSION SLIDES (2) from the EXTENSION RAILS (1) as shown in the upper diagram below. Be prepared, the parts are greasy.
- ✚ Fasten two EXTENSION RAILS (1) to the SMALL ENDS (C and D). Use six BLACK 1/2" PAN HEAD SCREWS (22).
- ✚ **NOTE:** For each EXTENSION RAIL, turn a SCREW into the hole shown in the enlarged diagram. Then, slide the inner cartridge of the EXTENSION RAIL in to find the other hole that lines up with the hole in the END. Turn a SCREW into this hole.
- ✚ **NOTE:** The EXTENSION SLIDES will be used later for the DRAWERS.

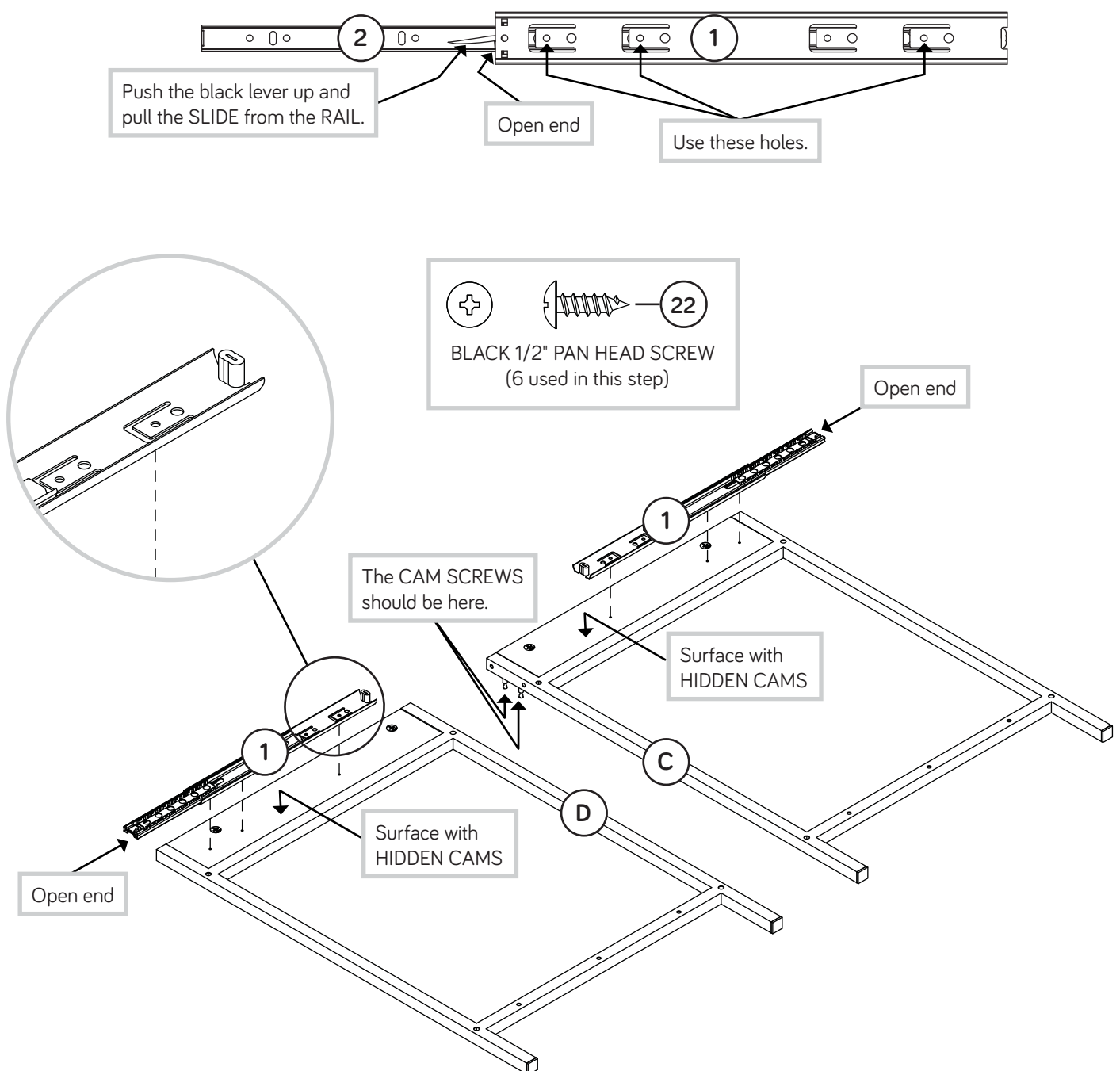

Step 18

- ✚ Carefully flip the SMALL RIGHT END (C) over.
- ✚ Fasten one EXTENSION RAIL (1) to the SMALL RIGHT END (C).
Use three BLACK 1/2" PAN HEAD SCREWS (22).
- ✚ **NOTE:** For each EXTENSION RAIL, turn a SCREW into the hole shown in the enlarged diagram. Then, slide the inner cartridge of the EXTENSION RAIL in to find the other hole that lines up with the hole in the END. Turn a SCREW into this hole.

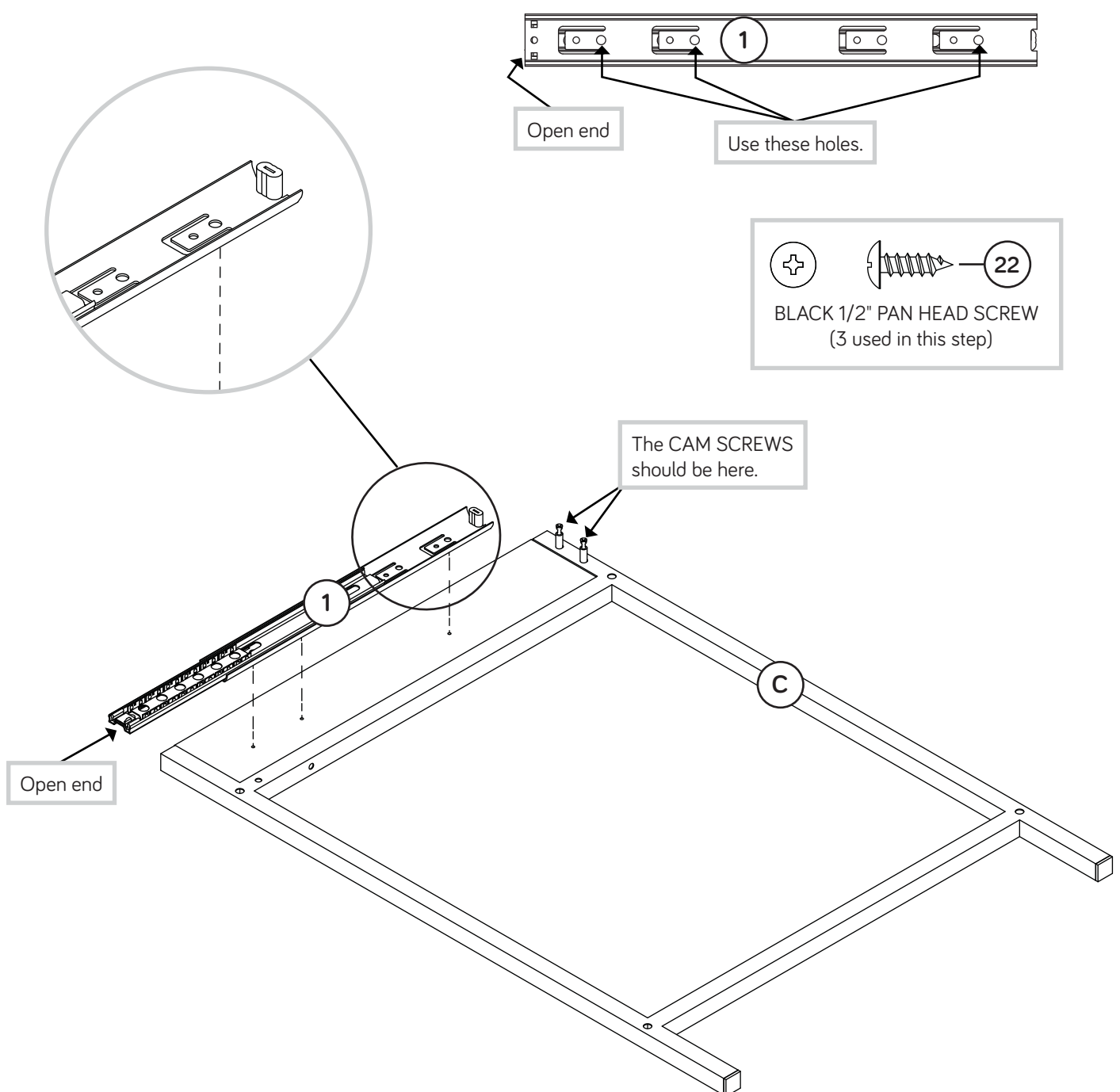

Step 19

- Fasten the SHORT BACK (J) to the SMALL WIRE BACK (K).
Use two BLACK 1-1/2" FLAT HEAD SCREWS (17).



Now might be a good time to refresh your drink.

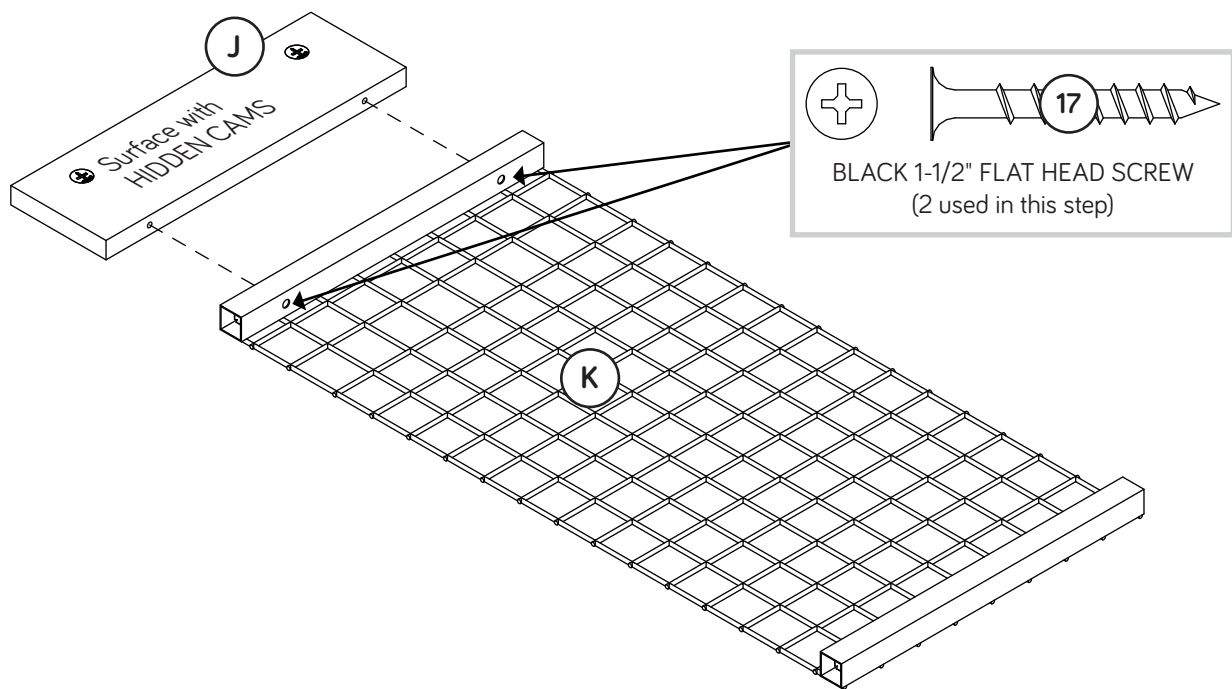

Step 20

- 🔧 **NOTE:** Start all of the SCREWS before completely tightening any of them.
- 🔧 Fasten the SMALL WIRE BACK (K) to the SMALL LEFT END (D). Tighten two BLACK 1-3/8" HEX HEAD SCREWS (16) using the L-Wrench (14).
- 🔧 Fasten the LEFT BOTTOM (W) to the SMALL LEFT END (D). Tighten three BLACK 1/2" HEX HEAD SCREWS (20) using the L-Wrench (14).
- 🔧 Fasten the SHORT LEFT TUBES (X) to the SMALL LEFT END (D). Tighten two BLACK 1-3/8" HEX HEAD SCREWS (16) using the L-Wrench (14).

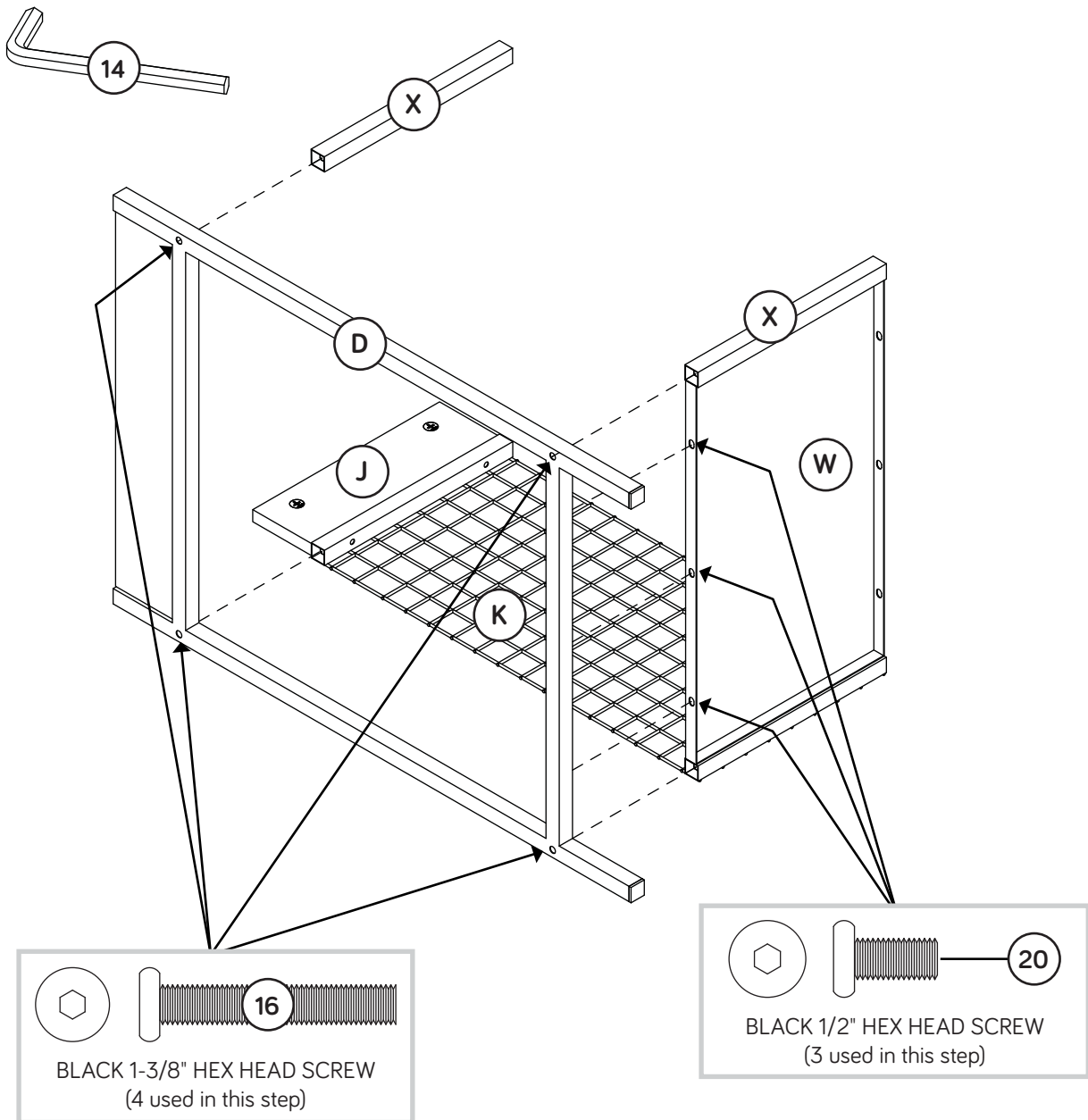

Step 21

- 🔩 **NOTE:** Start all of the SCREWS before completely tightening any of them.
- 🔩 Fasten the SMALL RIGHT END (C) to the SMALL WIRE BACK (K) and SHORT LEFT TUBES (X). Tighten four BLACK 1-3/8" HEX HEAD SCREWS (16) using the L-Wrench (14).
- 🔩 Fasten the SMALL RIGHT END (C) to the LEFT BOTTOM (W). Tighten three BLACK 1/2" HEX HEAD SCREWS (20) using the L-Wrench (14).
- 🔩 **NOTE:** Now, completely tighten all of the SCREWS from Steps 20-21.

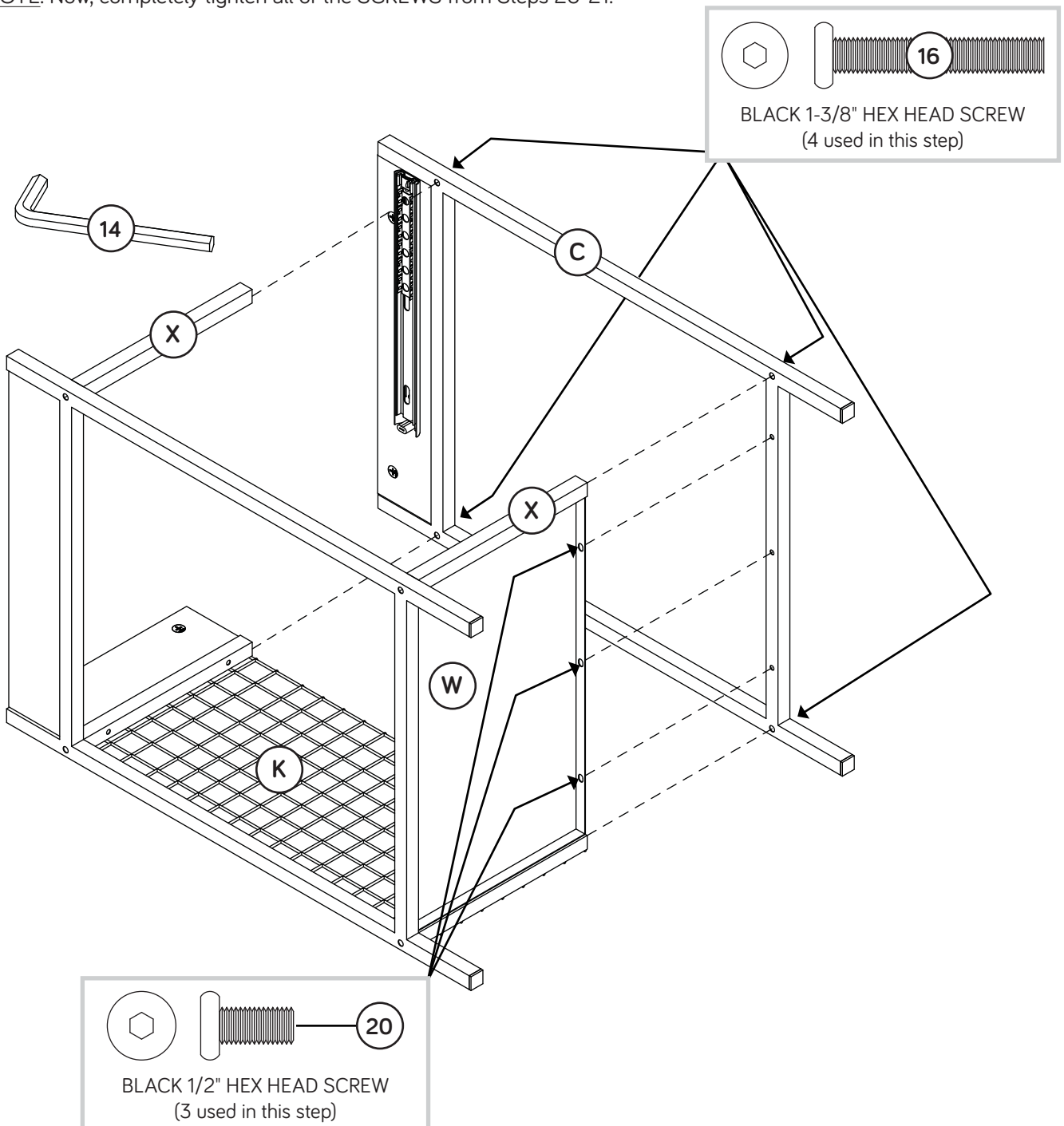

Step 22

- Fasten the SHORT TUBES (AA) to the SMALL UPRIGHTS (H and I). Tighten two HIDDEN CAMS.
- Fasten one EXTENSION RAIL (1) to the SMALL LEFT UPRIGHT (I). Use three BLACK 1/2" PAN HEAD SCREWS (22).
- NOTE:** For each EXTENSION RAIL, turn a SCREW into the hole shown in the enlarged diagram. Then, slide the inner cartridge of the EXTENSION RAIL in to find the other hole that lines up with the hole in the UPRIGHT. Turn a SCREW into this hole.

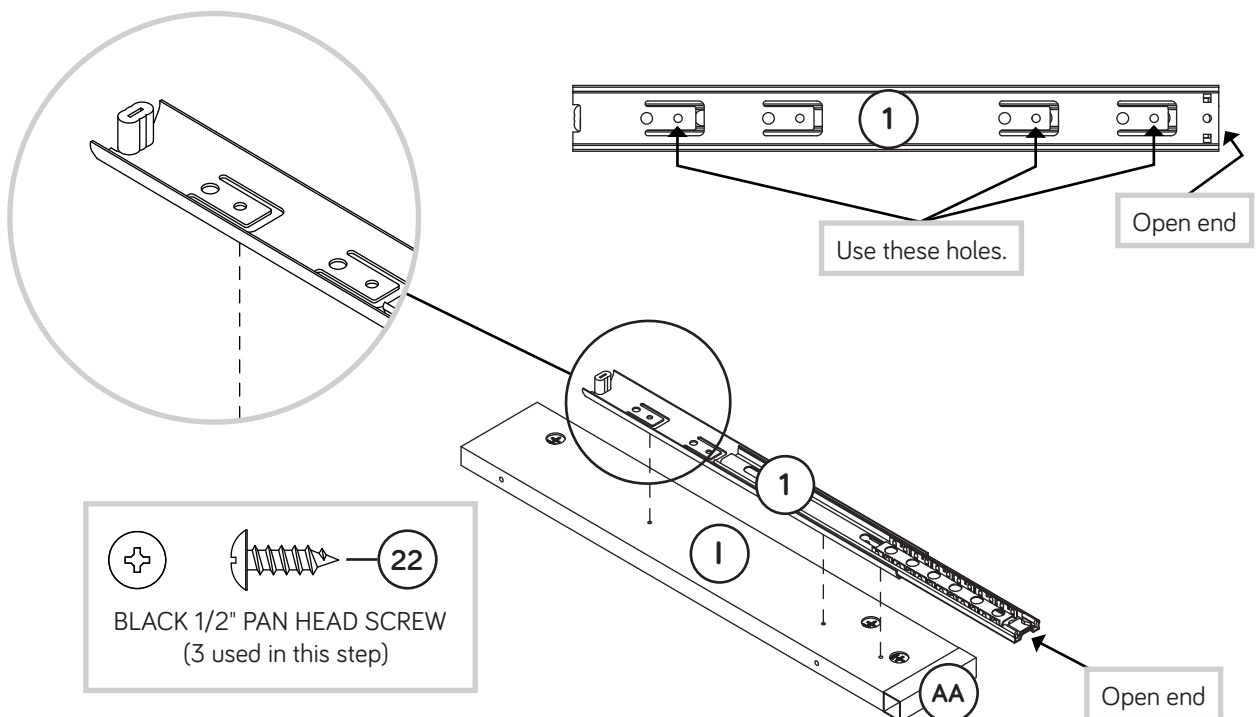
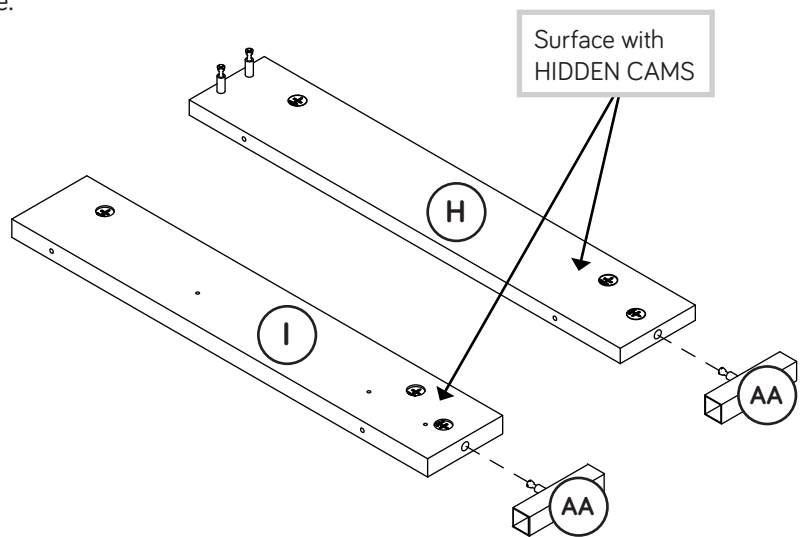

Step 23

- ✚ Insert one WOOD DOWEL (7) into the short edge of the SMALL LEFT UPRIGHT (I).
- ✚ Fasten the SMALL LEFT UPRIGHT (I) to the LONG BACK (L). Use one BLACK 1-1/2" FLAT HEAD SCREW (17).
- ✚ **NOTE:** Be sure the WOOD DOWEL in the SMALL LEFT UPRIGHT inserts into the LONG BACK.
- ✚ Fasten the SMALL RIGHT UPRIGHT (H) to the LONG BACK (L). Tighten two HIDDEN CAMS.
- ✚ Peel one APPLIQUE from the BROWN APPLIQUE CARD (12) and stick it onto the SCREW head.

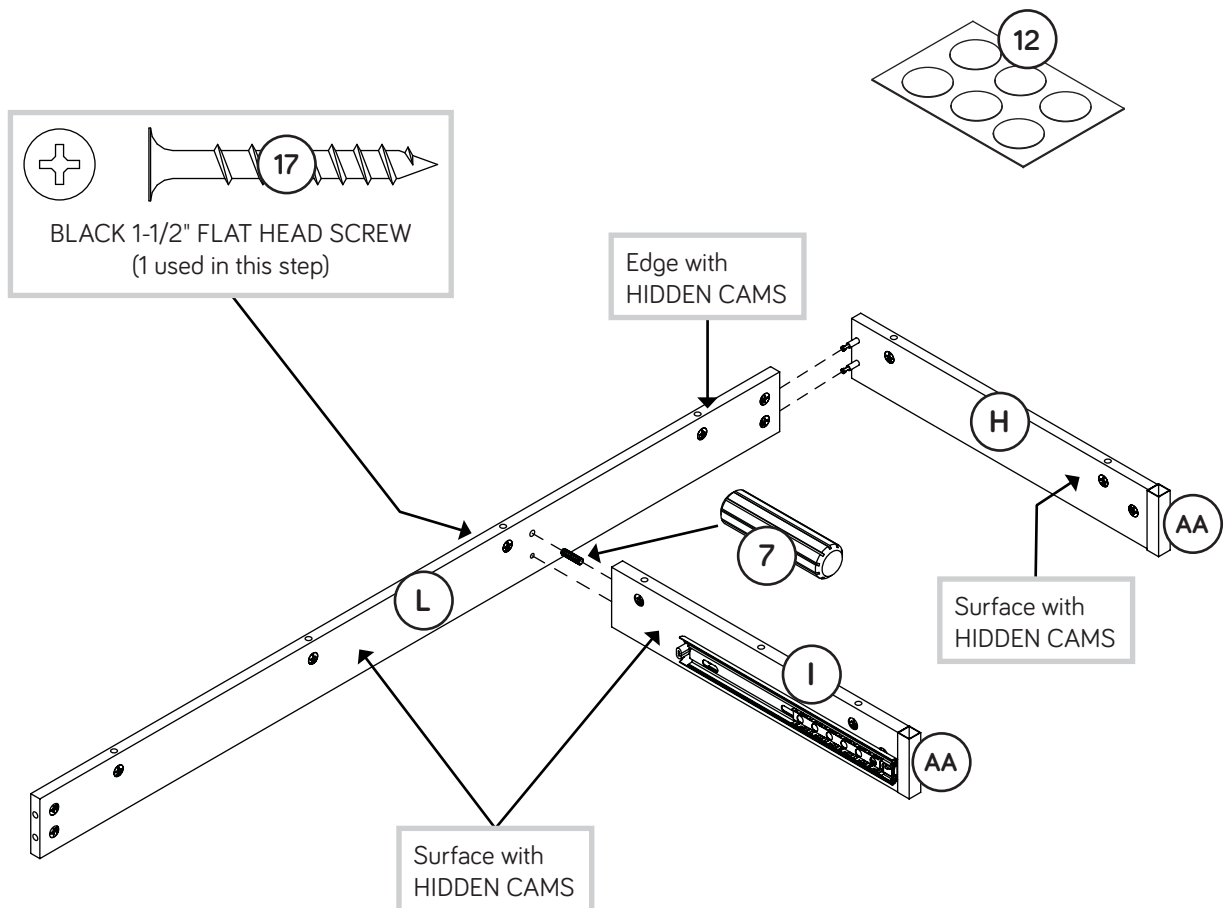

Step 24

⚠ **NOTE:** Use extra care in this step while lifting and placing the assembled parts from Step 23 into the hutch part of the desk.

⚠ Fasten the SMALL UPRIGHTS (H and I) to the SMALL TOP (F). Use four BLACK 2-1/4" PAN HEAD SCREWS (15).

⚠ **NOTE:** You may need to loosen and then retighten some screws to fasten the SMALL UPRIGHTS.

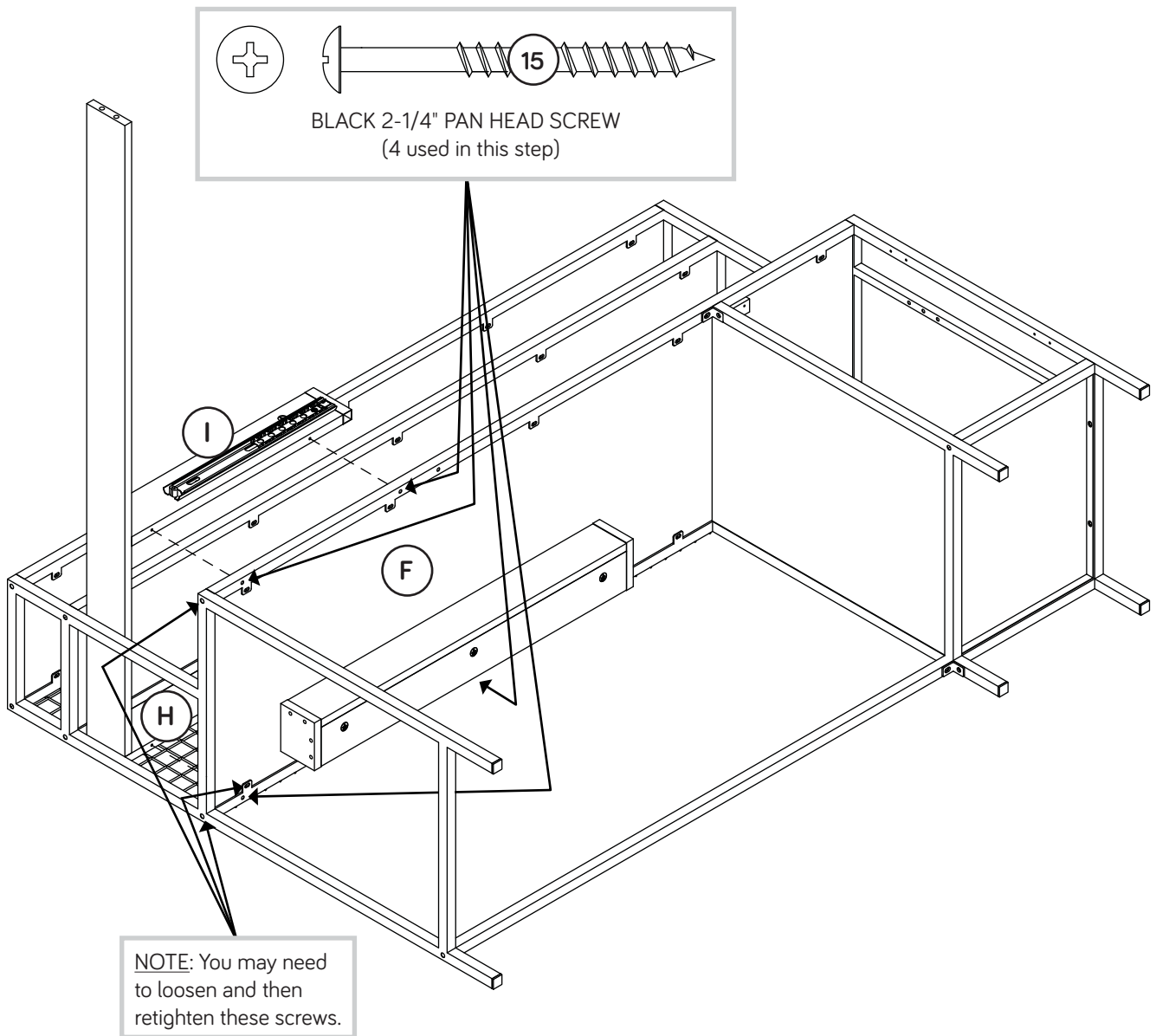

Step 25

- ⚠ **NOTE:** Do not lift up on the LONG BACK (L).
- ⚠ With someone's help, carefully stand the two assemblies upright.
- ⚠ Fasten the SMALL RIGHT END (C) to the LONG BACK (L).
Tighten two HIDDEN CAMS.

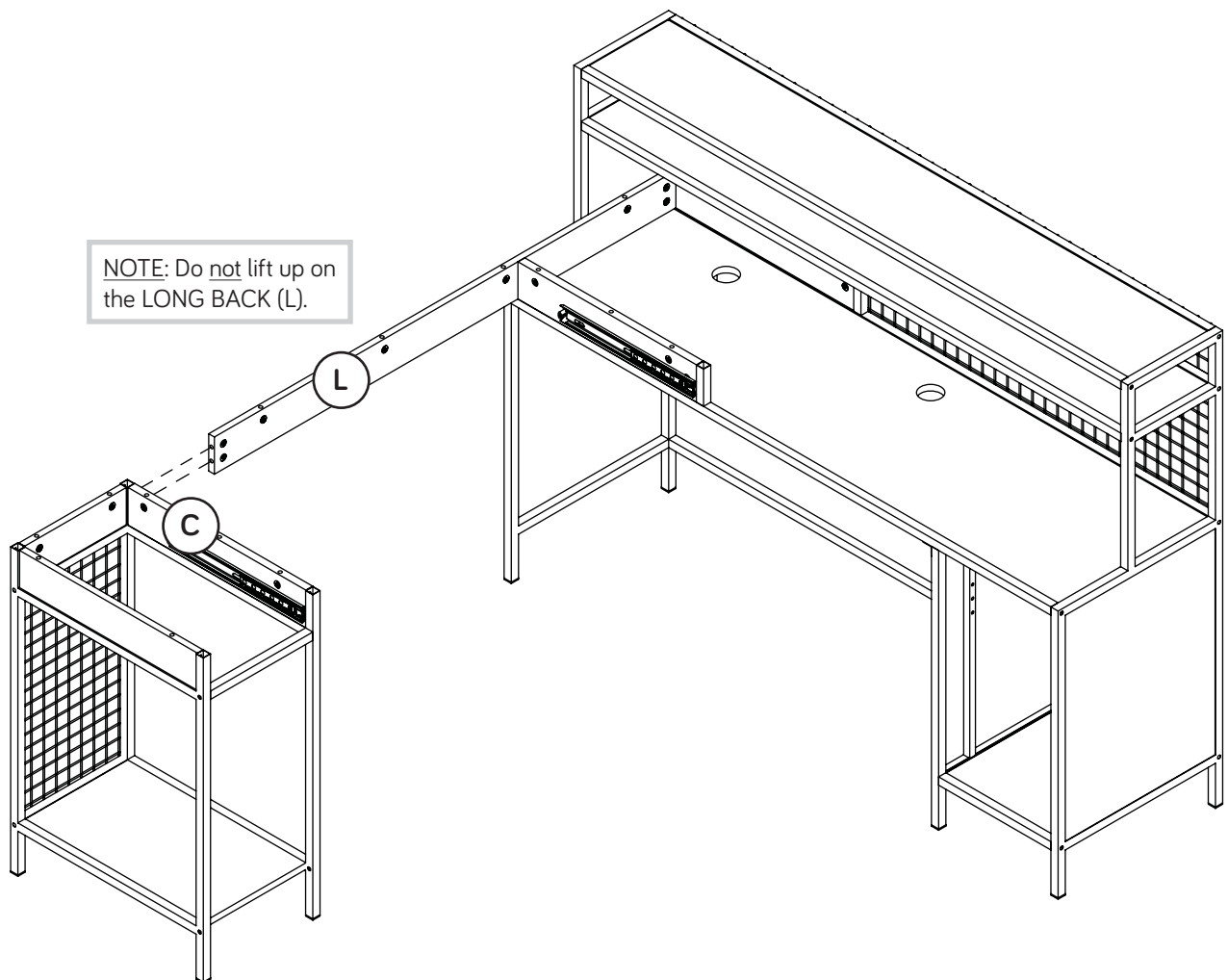

Step 26

- Fasten the LONG LEFT TUBE (Z) to the FRONT RIGHT TUBE (BB) on the SMALL TOP (F). Tighten one BLACK 1/2" HEX HEAD SCREW (20) using the L-Wrench (14).
- Fasten one METAL BRACKET (8) to the LONG LEFT TUBE (Z) and SMALL RIGHT END (C). Tighten two BLACK 1/2" HEX HEAD SCREWS (20) using the L-Wrench (14).

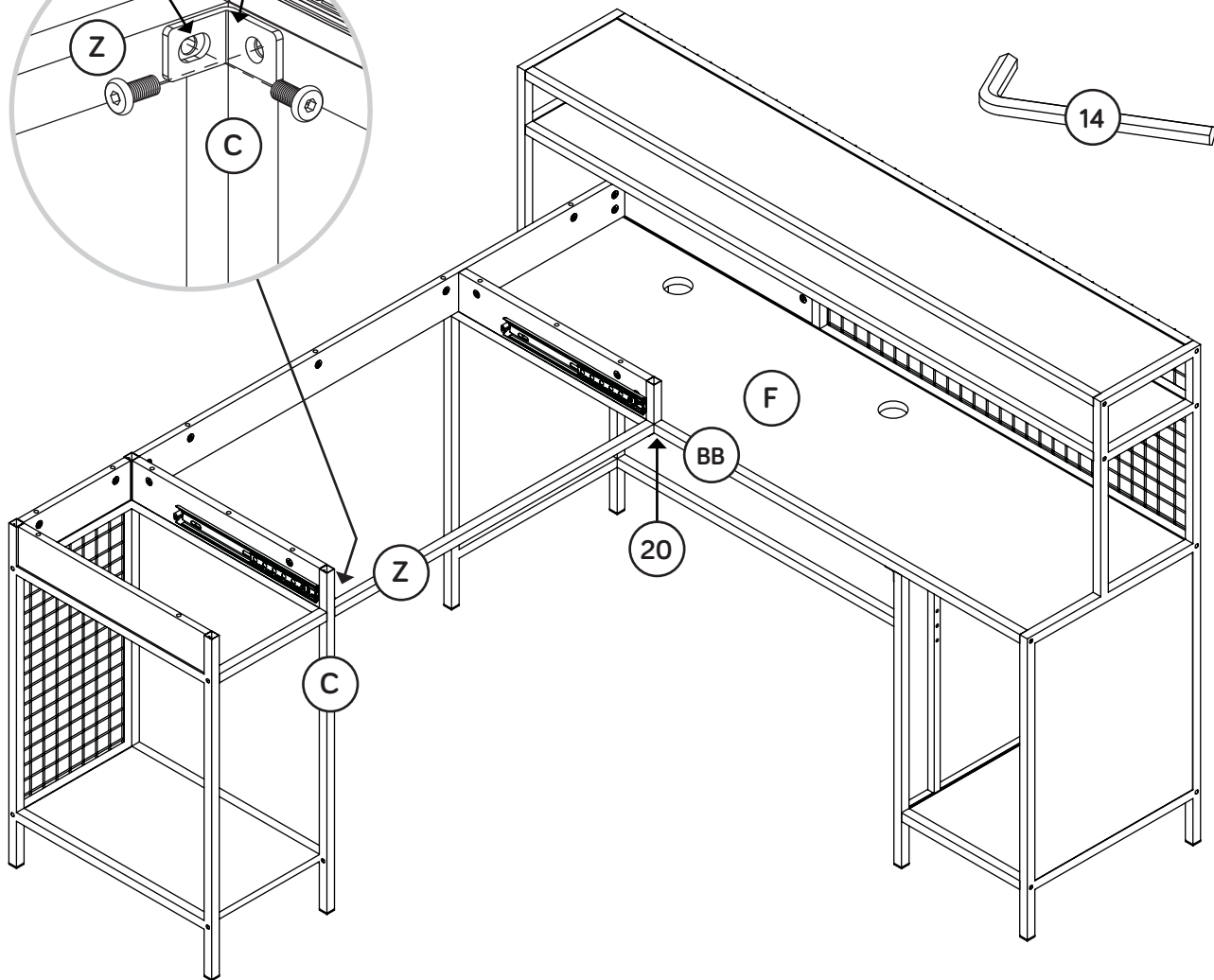
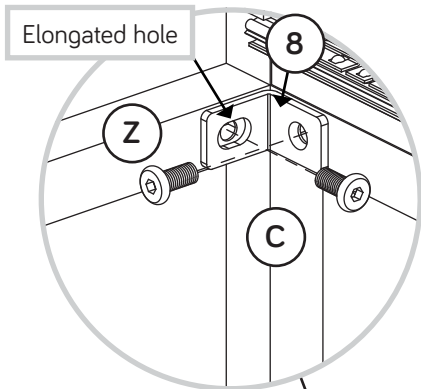
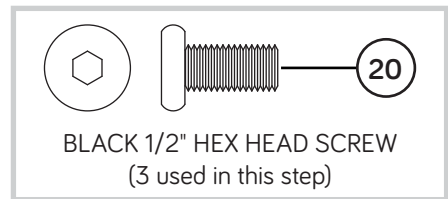

Step 27

- ✚ Insert two WOOD DOWELS (7) into the SMALL RIGHT END (C) and SMALL LEFT UPRIGHT (I).
- ✚ Fasten the LARGE TOP (G) to the SMALL ENDS (C and D), SMALL UPRIGHTS (H and I), and BACKS (J and L). Tighten fourteen HIDDEN CAMS.
- ✚ **NOTE:** Be sure the WOOD DOWELS in the SMALL RIGHT END and SMALL LEFT UPRIGHT insert into the LARGE TOP.

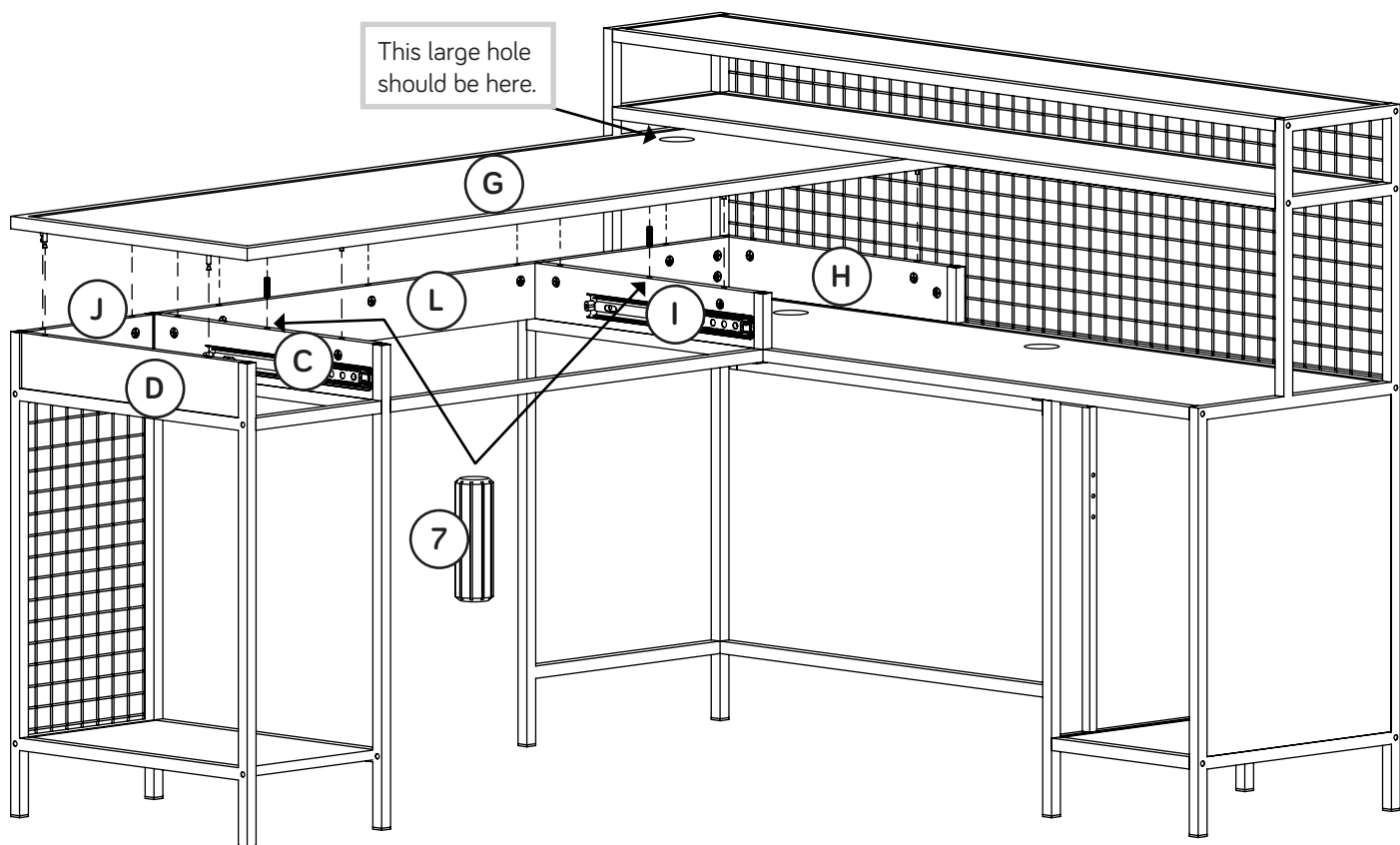

Step 28

- With your straight edge screwdriver, turn four SHELF PINS (9) into the hole locations of your choice in the LARGE RIGHT END (A) and LARGE UPRIGHT (E). Set the SHELF (U) onto the SHELF PINS.

Zzz

Almost time to celebrate! With a nap.

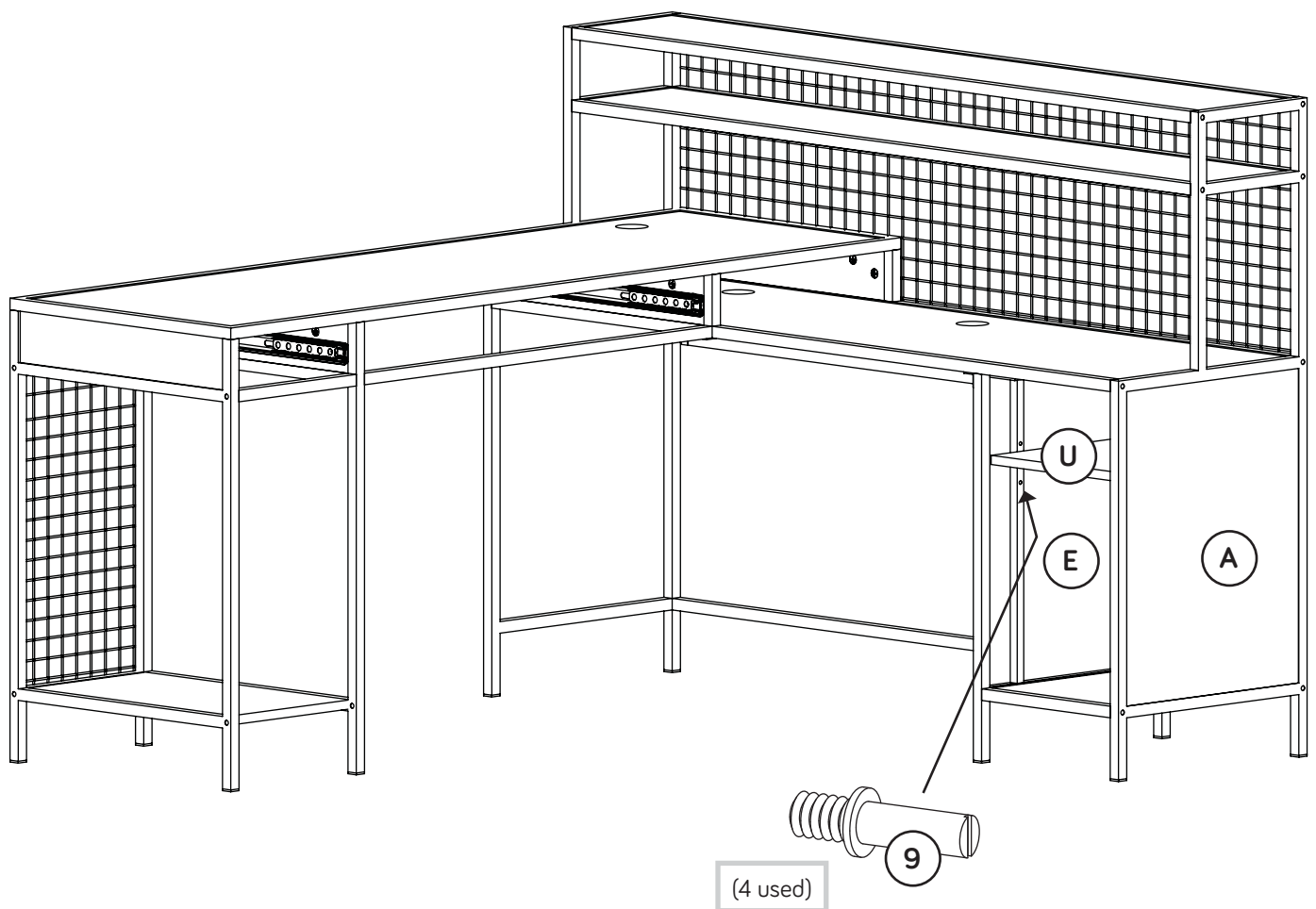

Step 29

- Fasten the DOOR (OO) to the LARGE RIGHT END (A).
Use four BLACK 1/2" FLAT HEAD SCREWS (21).
- Insert three GROMMETS WITH CAPS (11) into the large holes in the TOPS (F and G).

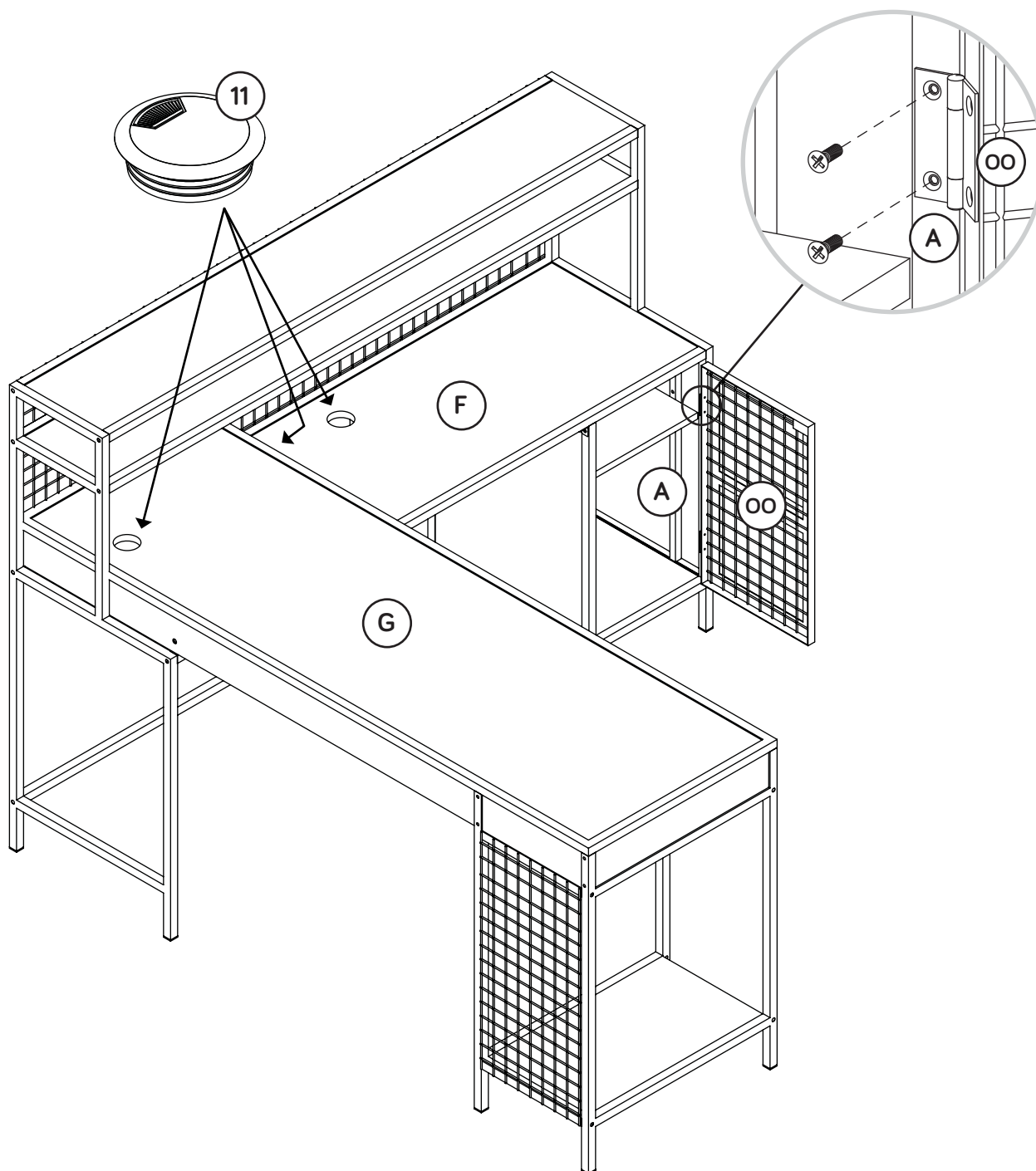
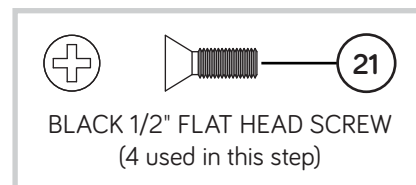

Step 30

1

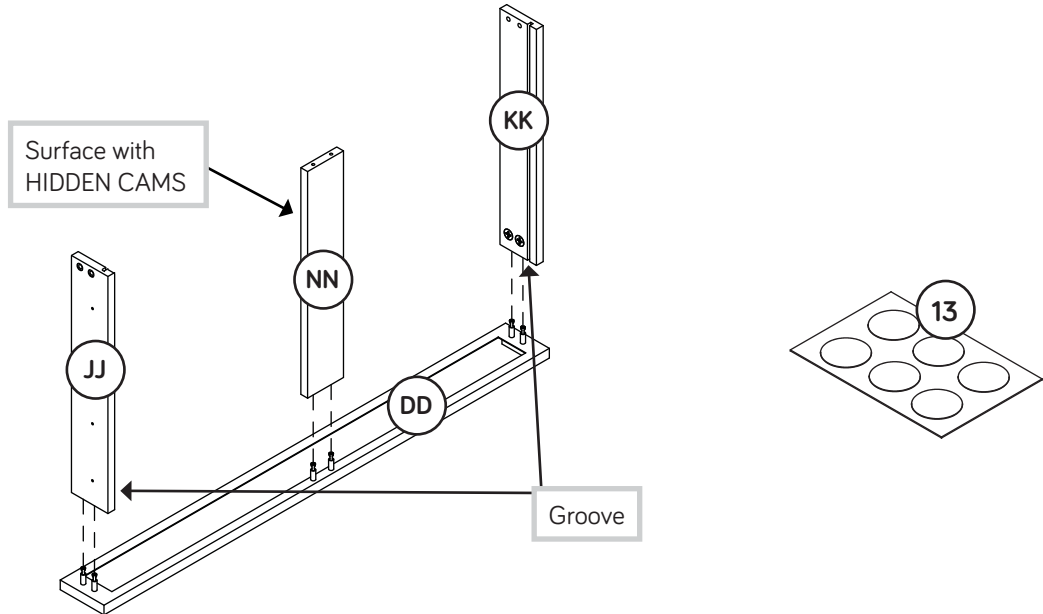

Fasten the LARGE DRAWER SIDES (JJ and KK) and LARGE DRAWER BRACE (NN) to the LARGE DRAWER FRONT (DD). Tighten six HIDDEN CAMS.

Peel the APPLIQUES from the BLACK APPLIQUE CARD (13) and stick them onto each HIDDEN CAM.

2

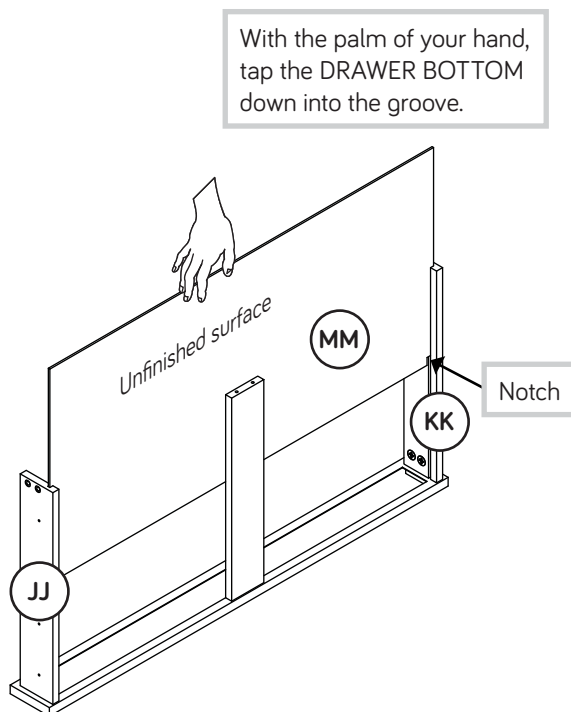

Slide the LARGE DRAWER BOTTOM (MM) into the grooves in the LARGE DRAWER SIDES (JJ and KK).

3

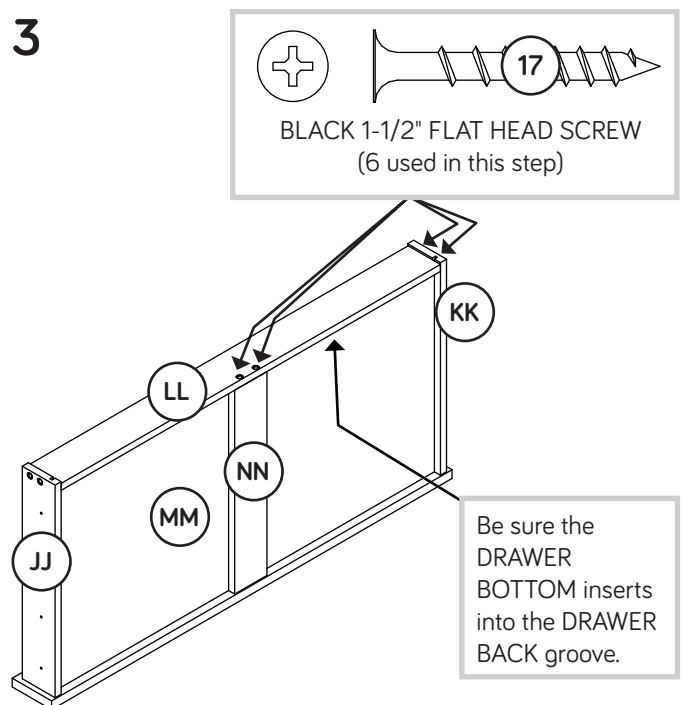

Fasten the LARGE DRAWER BACK (LL) to the LARGE DRAWER SIDES (JJ and KK) and LARGE DRAWER BRACE (NN). Use six BLACK 1-1/2" FLAT HEAD SCREWS (17).

NOTE: Be sure the LARGE DRAWER BOTTOM (MM) inserts into the groove of the LARGE DRAWER BACK (LL).

Step 31

1

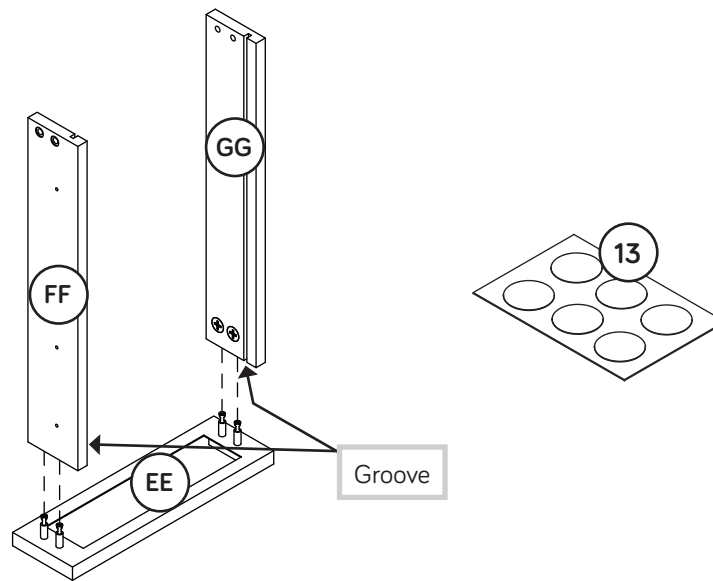

- ✚ Fasten the SMALL DRAWER SIDES (FF and GG) to the SMALL DRAWER FRONT (EE). Tighten four HIDDEN CAMS.
- ✚ Peel the APPLIQUES from the BLACK APPLIQUE CARD (13) and stick them onto each HIDDEN CAM.

2

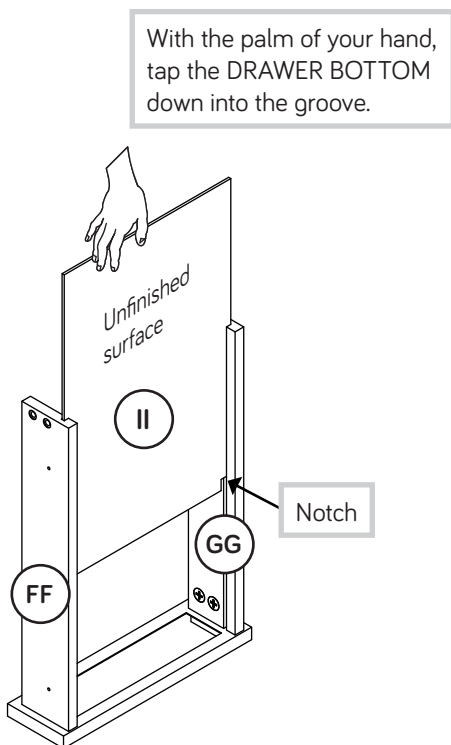

With the palm of your hand, tap the DRAWER BOTTOM down into the groove.

- ✚ Slide the SMALL DRAWER BOTTOM (II) into the grooves in the SMALL DRAWER SIDES (FF and GG).

3

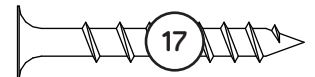
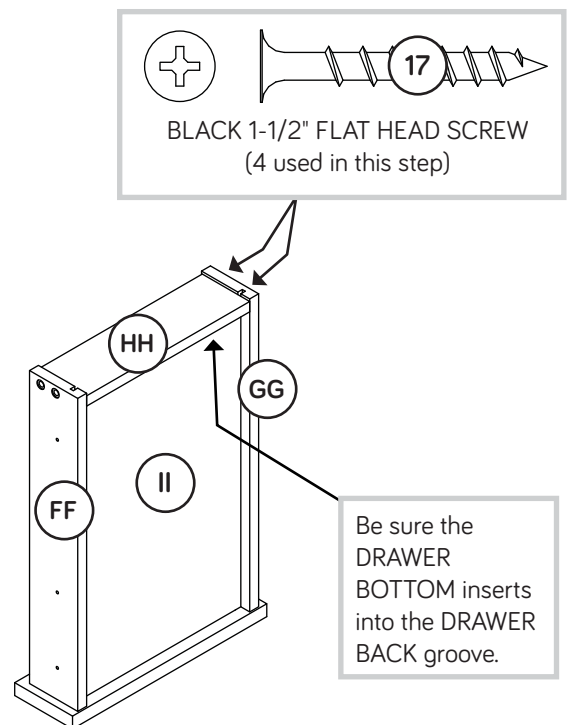

BLACK 1-1/2" FLAT HEAD SCREW
(4 used in this step)

Be sure the DRAWER BOTTOM inserts into the DRAWER BACK groove.

- ✚ Fasten the SMALL DRAWER BACK (HH) to the SMALL DRAWER SIDES (FF and GG). Use four BLACK 1-1/2" FLAT HEAD SCREWS (17).
- ✚ NOTE: Be sure the SMALL DRAWER BOTTOM (II) inserts into the groove of the SMALL DRAWER BACK (HH).

Step 32

- Fasten two EXTENSION SLIDES (2) to the LARGE DRAWER SIDES (JJ and KK). Use six BLACK 1/2" PAN HEAD SCREWS (22).

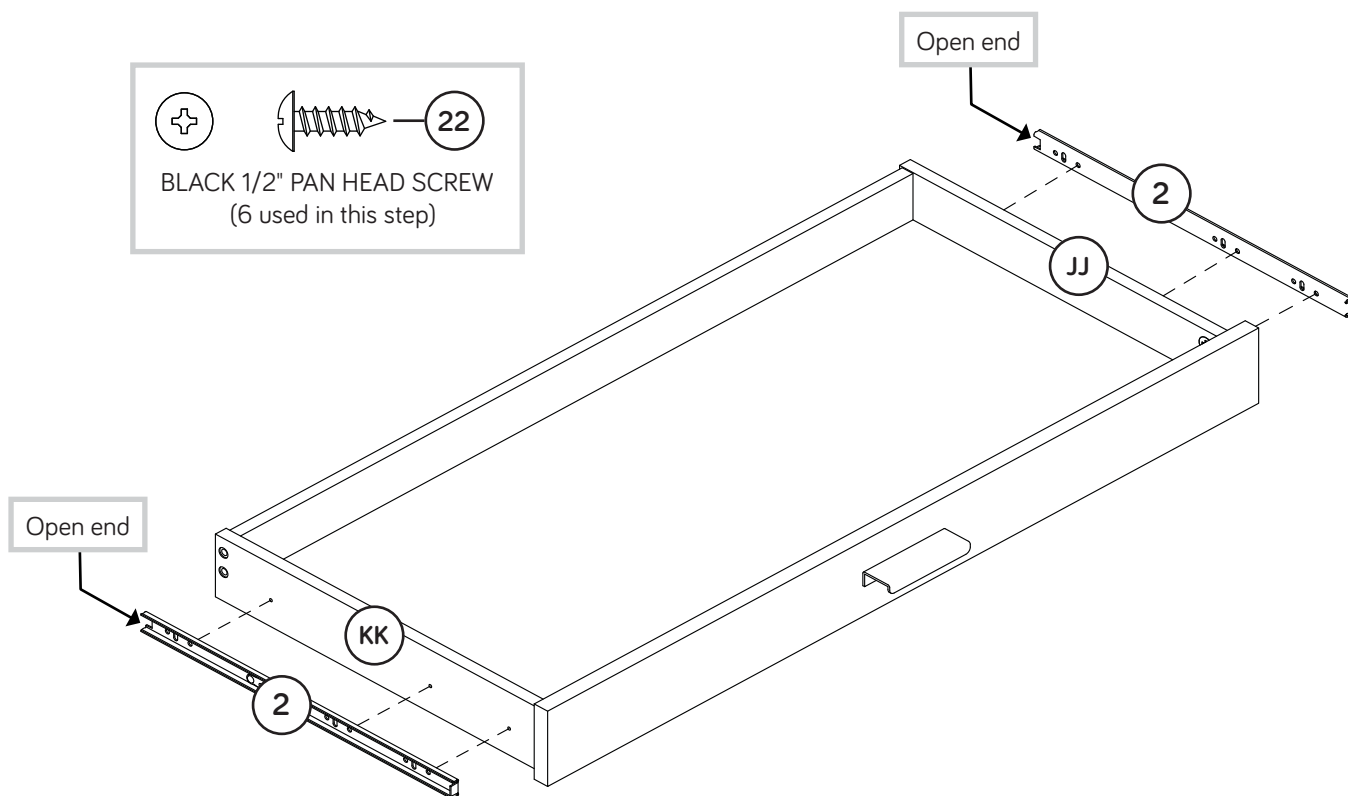
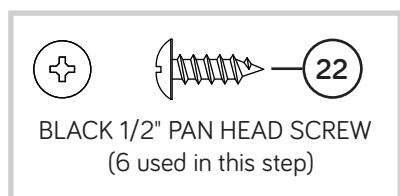
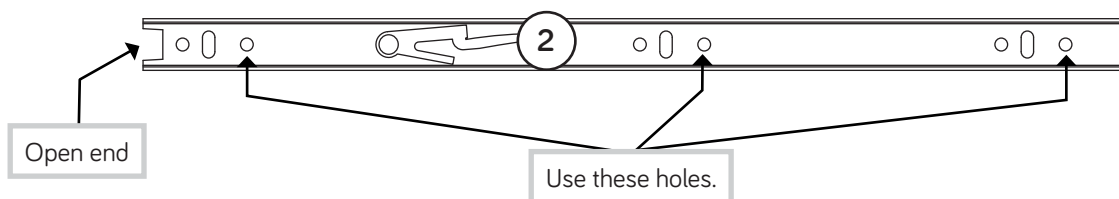

Step 33

- Fasten two EXTENSION SLIDES (2) to the SMALL DRAWER SIDES (FF and GG). Use six BLACK 1/2" PAN HEAD SCREWS (22).

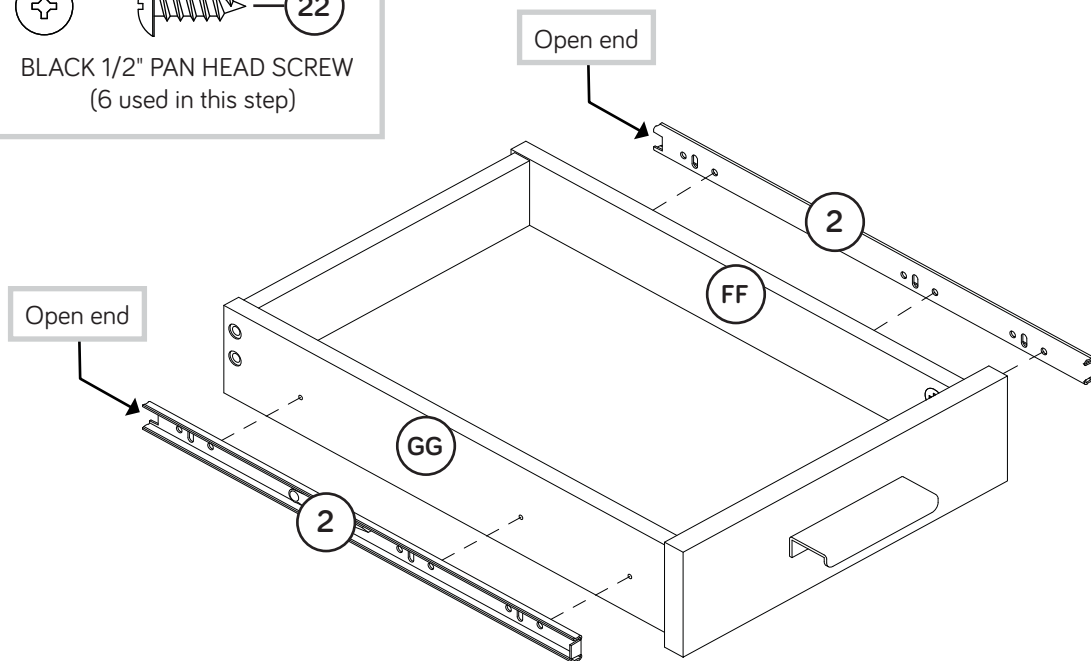
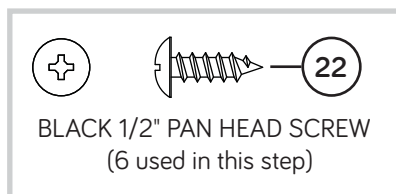
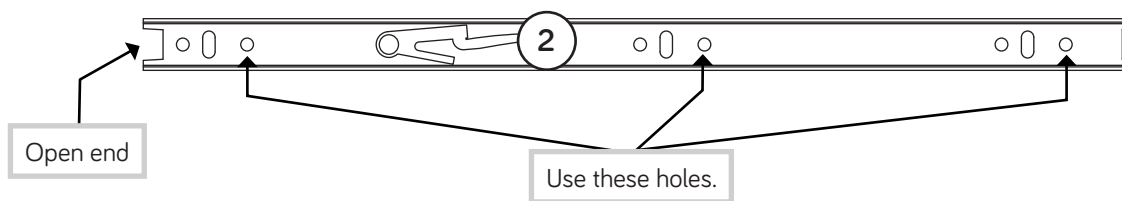

Step 34

- ✚ To insert a drawer into your unit, line up the EXTENSION SLIDES on the drawer with the EXTENSION RAILS on the unit and push the drawer into the unit until the drawer is fully inserted. The drawer will push in hard until it is all the way in, then it will slide in and out easier.
- ✚ Peel the APPLIQUES from the BROWN APPLIQUE CARD (12) and stick them onto each visible HIDDEN CAM.
- ✚ **NOTE:** Please read the back pages of the instruction booklet for important safety information.
- ✚ This completes assembly. Clean with a damp cloth. Wipe dry.

★ **And to celebrate, why not share your success story?**

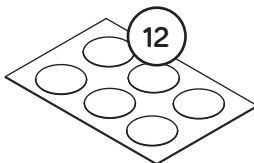
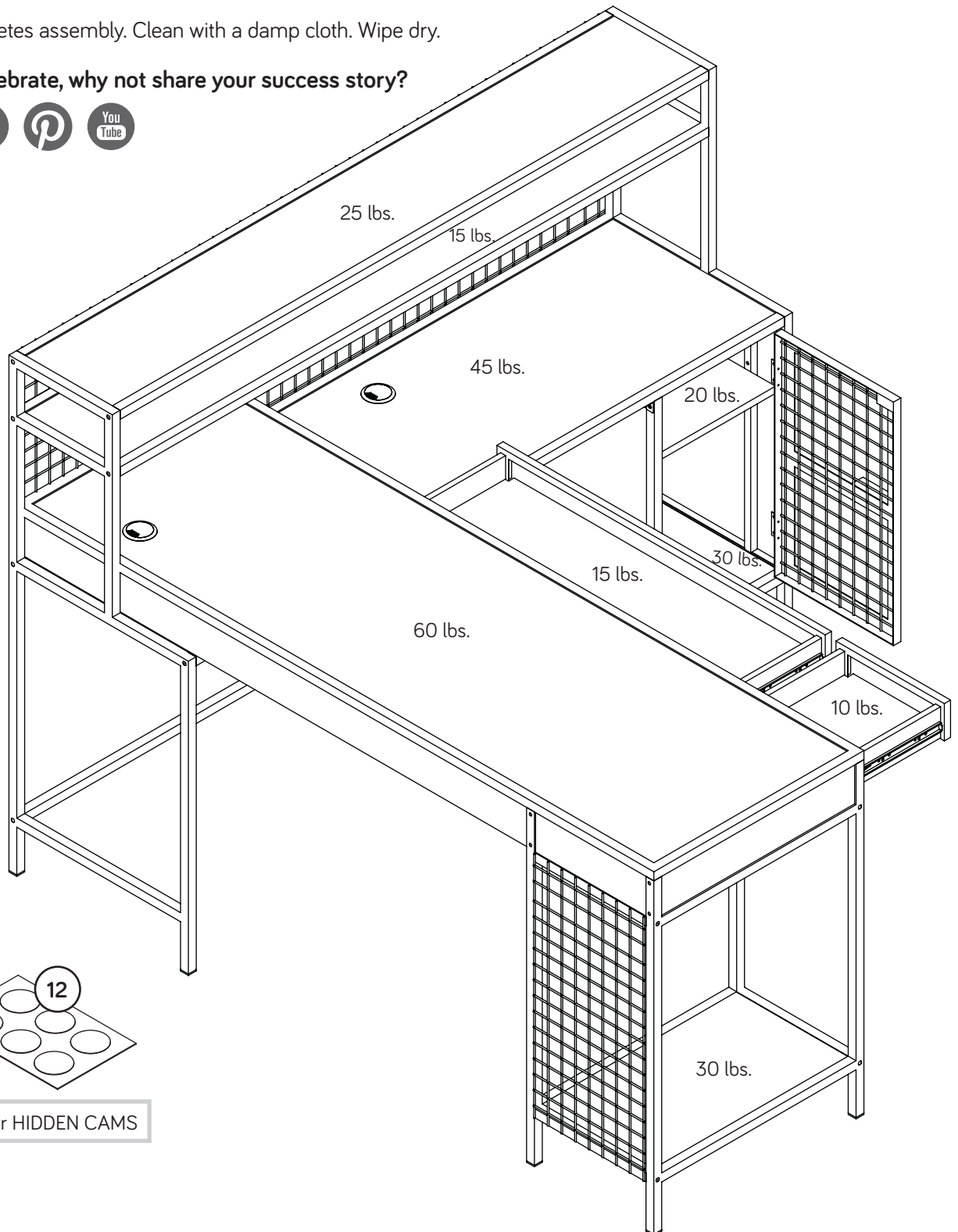

To cover HIDDEN CAMS

⚠ WARNING

Please use your furniture correctly and safely. Improper use can cause safety hazards, or damage to your furniture or household items. ***Carefully read the following chart.***

Look out for:	What can happen:	How to avoid the problem:
<ul style="list-style-type: none"> Overloaded shelves or drawers. Improper loading can cause the product to be top-heavy. 	<ul style="list-style-type: none"> Risk of injury. Top-heavy furniture can tip over. Overloaded shelves and drawers can break. 	<ul style="list-style-type: none"> Never exceed the weight limits shown in the instructions. Work from bottom to top when loading shelves and drawers. Place the heavier items on the lower shelves or in lower drawers.
<ul style="list-style-type: none"> Improperly moving furniture that is not designed and equipped with casters. 	<ul style="list-style-type: none"> Furniture can tip over or break if improperly moved. Physical injury. Furniture can be very heavy. Breakage of tops - particularly with double pedestal furniture (drawers at both ends). 	<ul style="list-style-type: none"> Unload shelves and drawers from top to bottom before moving the unit. Do not push furniture, especially on a carpeted floor. Have a friend help you lift the item and set it in place. Provide support to the center section of the top when lifting the furniture.
<ul style="list-style-type: none"> Placing TVs on furniture items that are not designed to support a television is hazardous. 	<ul style="list-style-type: none"> Risk of injury or death. TVs can be very heavy. Plus the weight and location of the picture tube tends to make TVs unbalanced and prone to tipping forward. 	<ul style="list-style-type: none"> This product is not designed to support a television.