

Get crafty

Craft Tower

Craft Collection | Model 5421419

NOTE: THIS INSTRUCTION BOOKLET CONTAINS **IMPORTANT** SAFETY INFORMATION.

PLEASE READ AND KEEP FOR FUTURE REFERENCE.

Table of Contents

Assembly Tools Required

Part Identification	3
Hardware Identification	4
Assembly Steps	5-28
Français	29-32
Español	33-36
Safety	37-38
Warranty	39

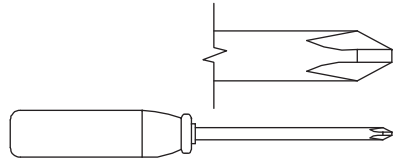

No. 2 Phillips Screwdriver
Tip Shown Actual Size

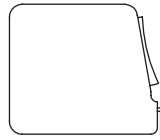

Tape Measure

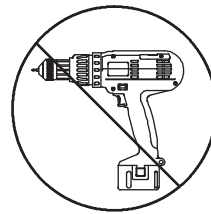

Skip the power trip.
This time.

Part Identification

Now you know
our ABCs.

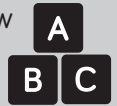

While not all parts are labeled, some of the parts will have a label or an inked letter on the edge to help distinguish similar parts from each other. Use this part identification to help identify similar parts.

A	LOWER RIGHT END (1)	I	LOWER BACK (1)	Q	LONG BASE MOLDING (2)
B	LOWER LEFT END (1)	J	CORK BOARD (1)	R	LEFT DRAWER SIDE (2)
C	TOP (1)	K	LOWER BRACE (1)	S	DRAWER BACK (2)
D	UPPER RIGHT END (1)	L	UPPER BRACE (1)	T	RIGHT DRAWER SIDE (2)
E	PEG BOARD (1)	M	BOTTOM (1)	U	DRAWER BOTTOM (2)
F	UPPER BACK (1)	N	TURNTABLE BOTTOM (1)	V	DRAWER FRONT (2)
G	SHELF (2)	O	BASE (1)	W	SHORT METAL SHELF (3)
H	LOWER SHELF (1)	P	SHORT BASE MOLDING (2)	X	LONG METAL SHELF (3)

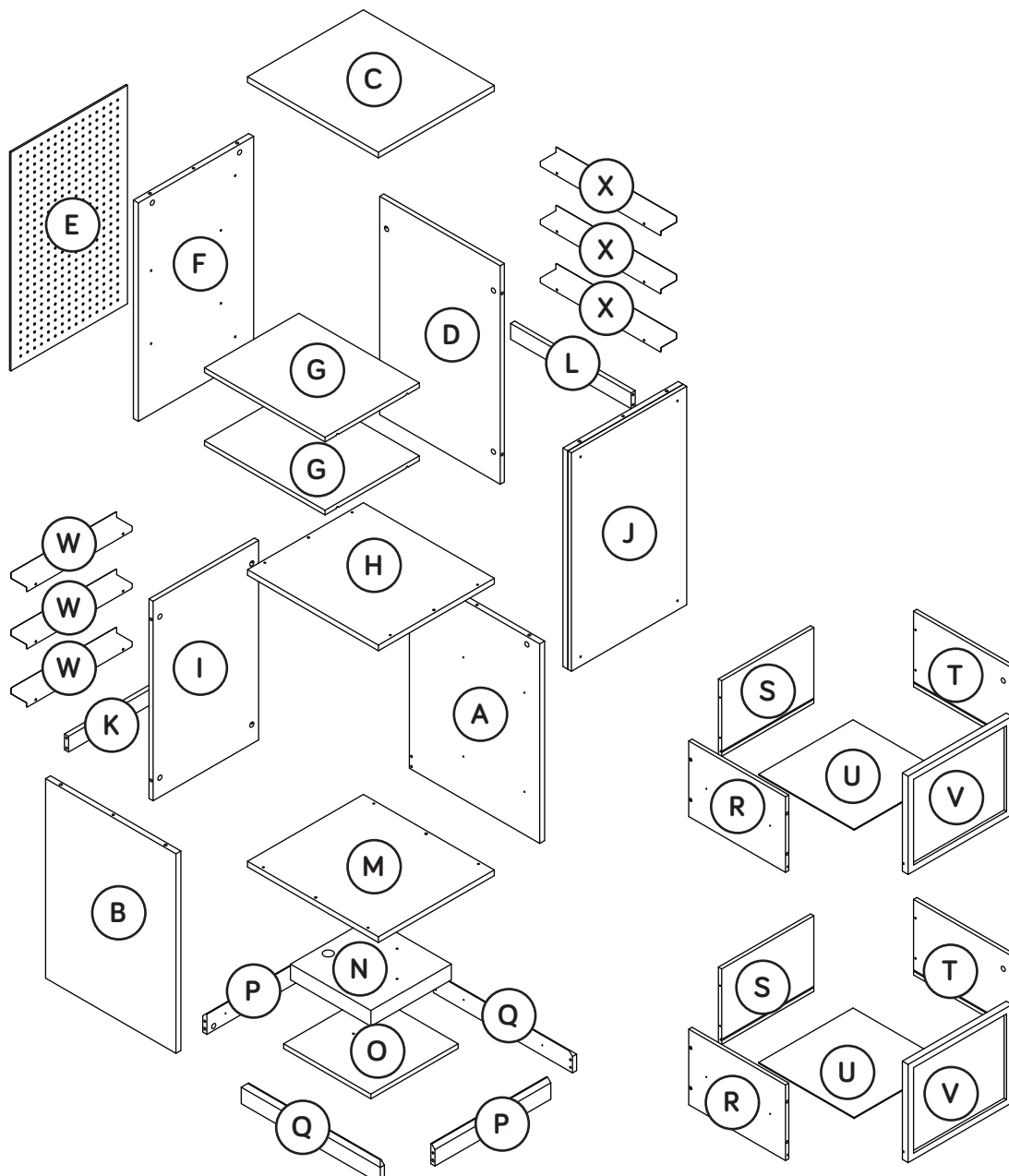

Hardware Identification

† Screws are shown actual size. You may receive extra hardware with your unit.

1 EXTENSION RAIL - 4 **2** EXTENSION SLIDE - 4 **3** HIDDEN CAM - 28 **4** CAM SCREW - 28

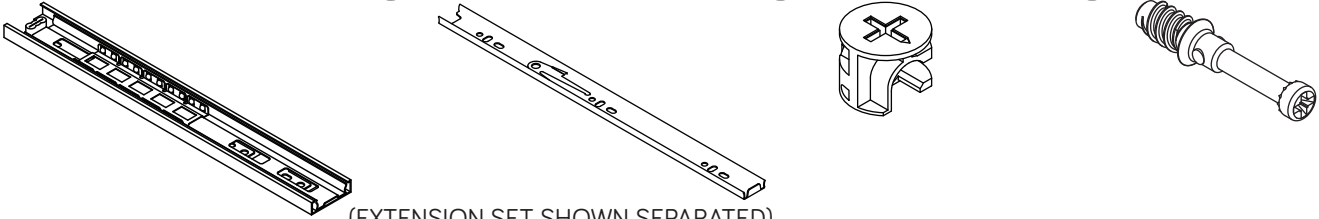

(EXTENSION SET SHOWN SEPARATED)

5 WOOD DOWEL - 20 **6** KNOB - 2 **7** CAM COVER CARD - 5 **8** METAL PIN - 8



9 METAL BRACKET - 8 **10** WASHER - 10 **11** SPACER - 6 **12** TURNTABLE - 1



13 SILVER 1-7/8" FLAT HEAD SCREW - 4 **14** SILVER 1-3/16" FLAT HEAD SCREW - 16



15 SILVER 1" PAN HEAD SCREW - 10 **17** SILVER 1/2" PAN HEAD SCREW - 42



18 SILVER 1/2" FLAT HEAD SCREW - 16 **19** SILVER 11/16" MACHINE SCREW - 2



Step 1

- ✚ Assemble your unit on a carpeted floor or on the empty carton to avoid scratching your unit or the floor.
- ✚ Push twenty-eight HIDDEN CAMS (3) into the LOWER ENDS (A and B), UPPER RIGHT END (D), UPPER BACK (F), LOWER BACK (I), CORK BOARD (J), SHORT BASE MOLDINGS (P) and DRAWER SIDES (R and T).

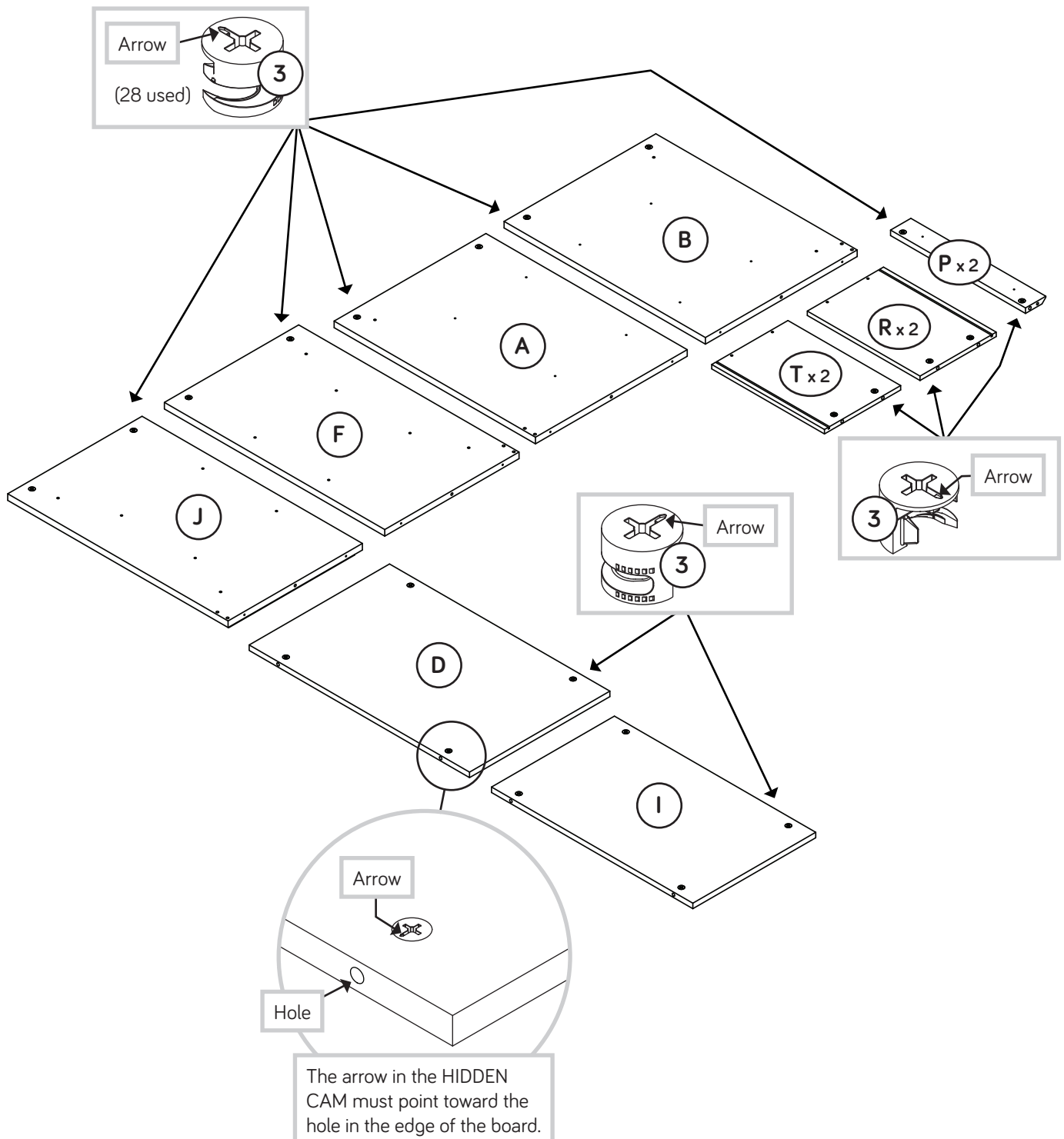

Step 2

- ✚ Flip the UPPER BACK (F) over and place a SPACER (11) over each hole.
- ✚ Place the PEGBOARD (E) onto the SPACERS (11). Fasten the PEGBOARD (E) to the UPPER BACK (F). Turn six SILVER 1" PAN HEAD SCREWS (15) through six WASHERS (10), through the PEGBOARD (E), through six SPACERS (11) and into the UPPER BACK (F).

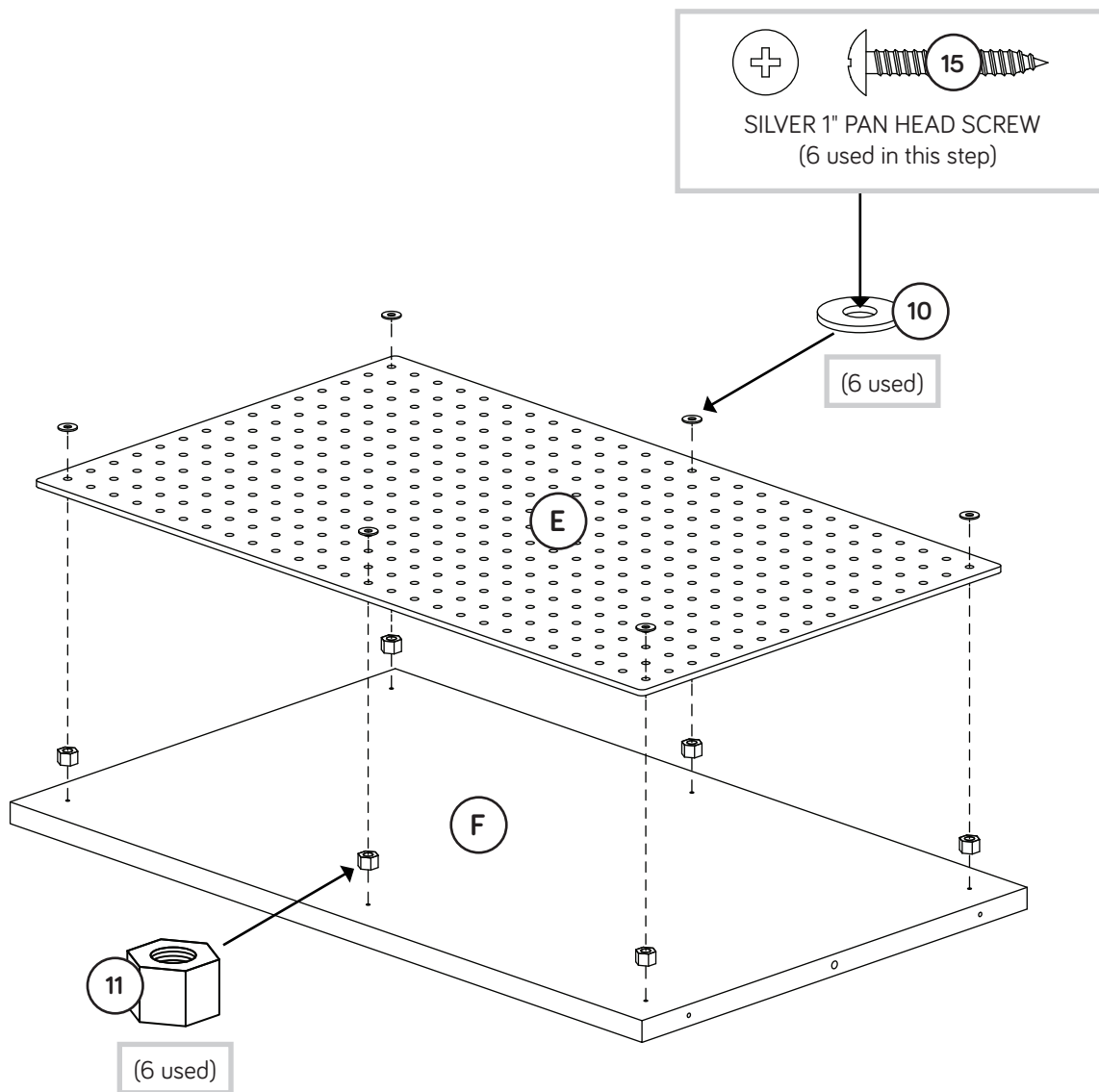

Step 3

- ✚ Flip the CORK BOARD (J) over.
- ✚ Turn four SILVER 1" PAN HEAD SCREWS (15) through four WASHERS (10) and into the CORK BOARD (J).



Just think. The sooner you do this, the sooner you do something else.

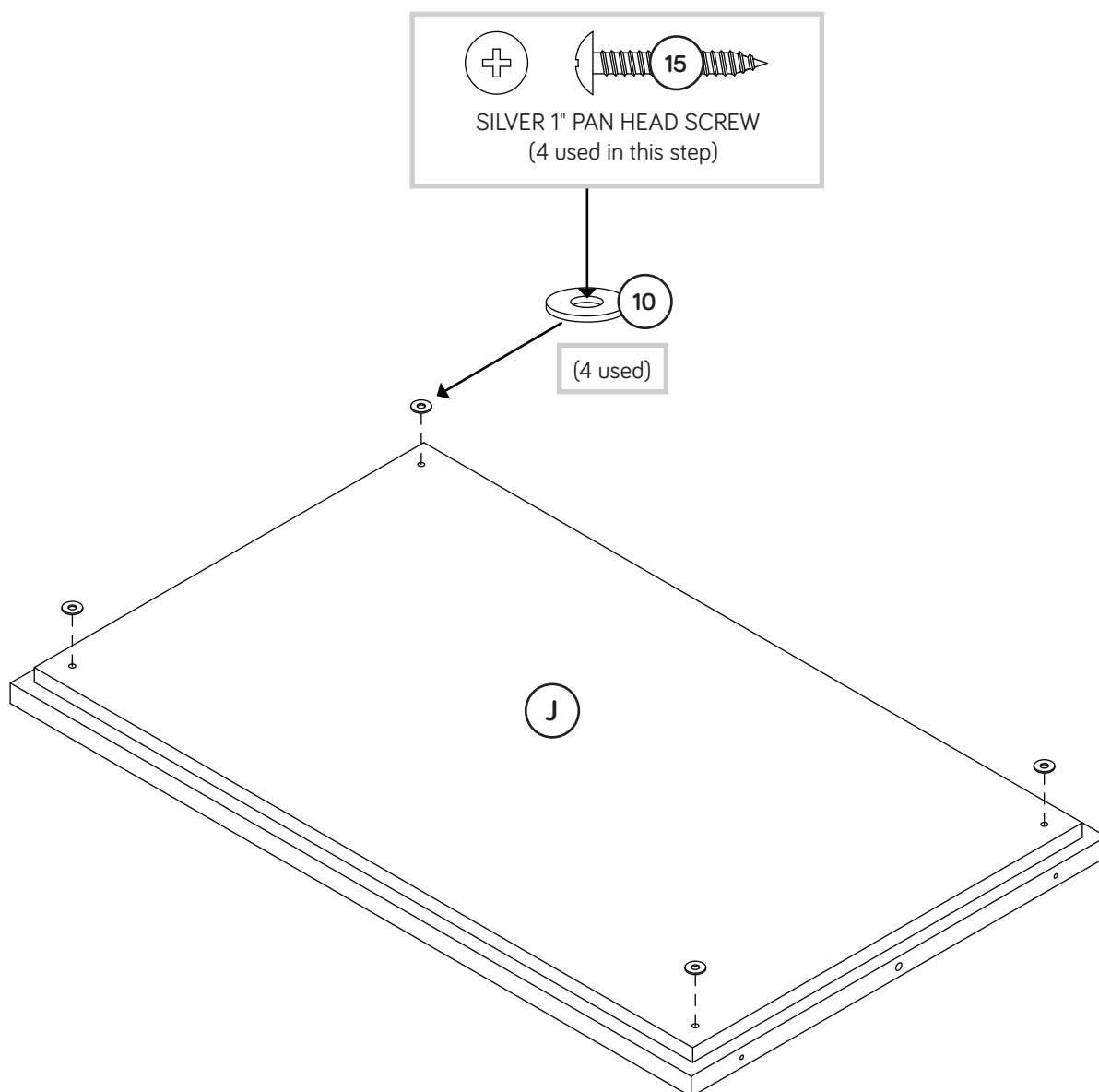

Step 4

Turn twenty-eight CAM SCREWS (4) into the LOWER ENDS (A and B), TOP (C), UPPER BACK (F), LOWER SHELF (H), CORK BOARD (J), LONG BASE MOLDINGS (Q), and DRAWER FRONTS (V).

NOTE: Use the exact holes shown.

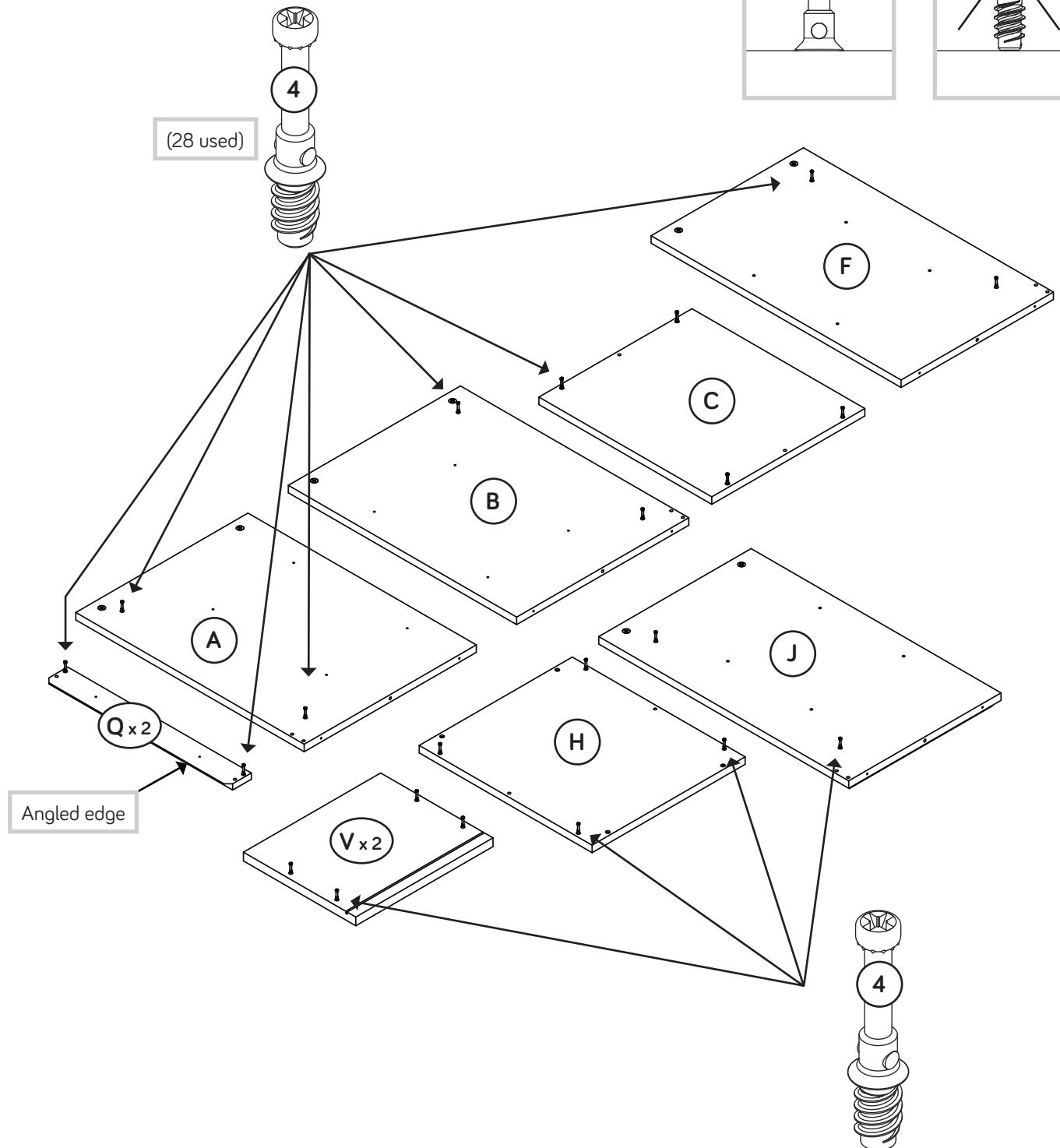
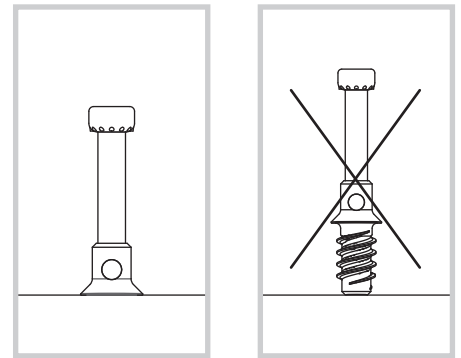

Step 5

- ✚ Insert two WOOD DOWELS (5) into the CORK BOARD (J).
Fasten the UPPER BRACE (L) to the CORK BOARD (J) by pushing the UPPER BRACE (L) onto the WOOD DOWELS.
- ✚ Fasten the UPPER RIGHT END (D) to the CORK BOARD (J).
Tighten two HIDDEN CAMS.

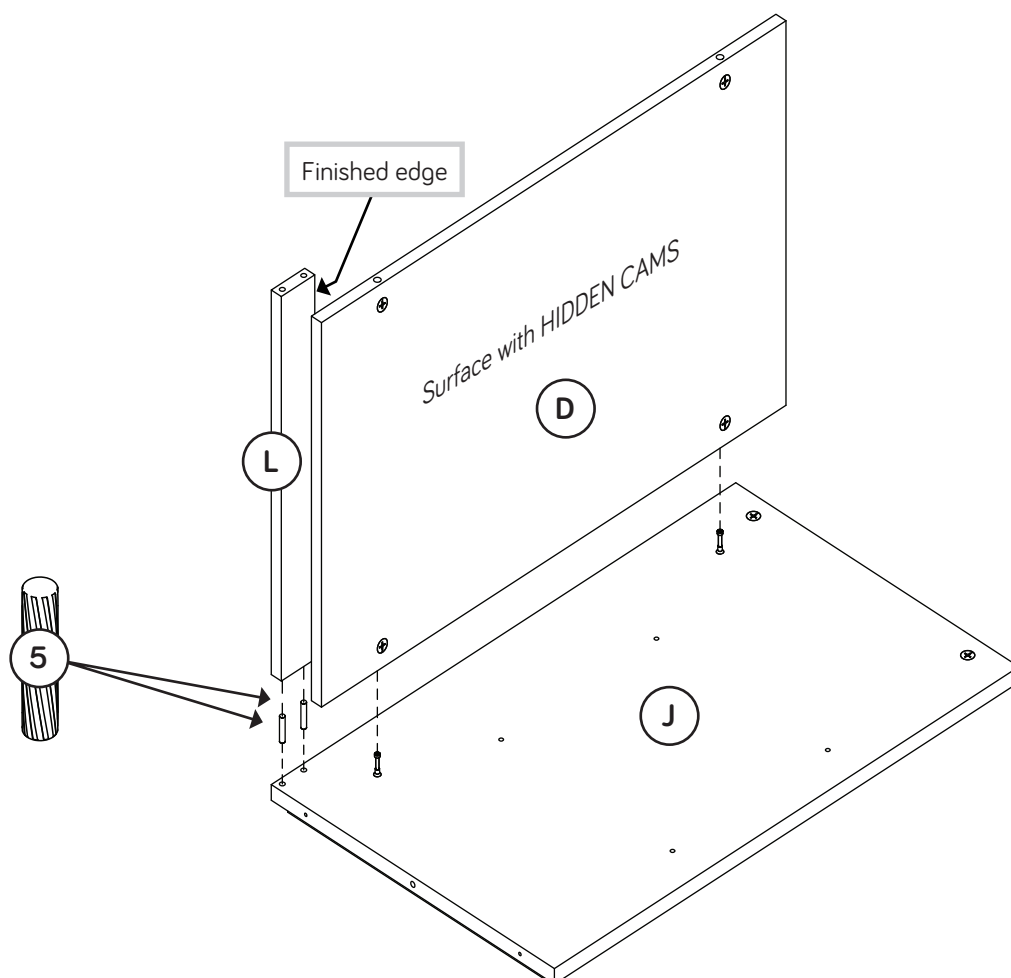
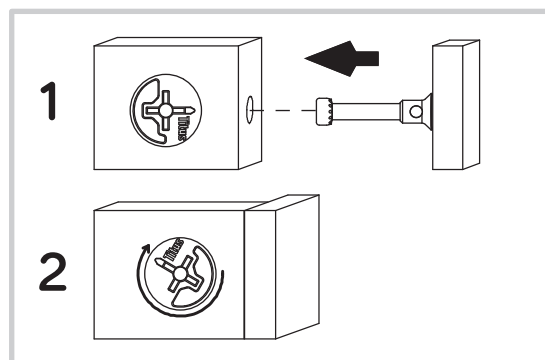

Step 6

- ✚ Insert two WOOD DOWELS (5) into the UPPER BRACE (L).
- ✚ Fasten the UPPER BACK (F) to the UPPER RIGHT END (D). Tighten two HIDDEN CAMS.
- ✚ **NOTE:** Be sure the WOOD DOWELS in the UPPER BRACE insert into the holes in the UPPER BACK.

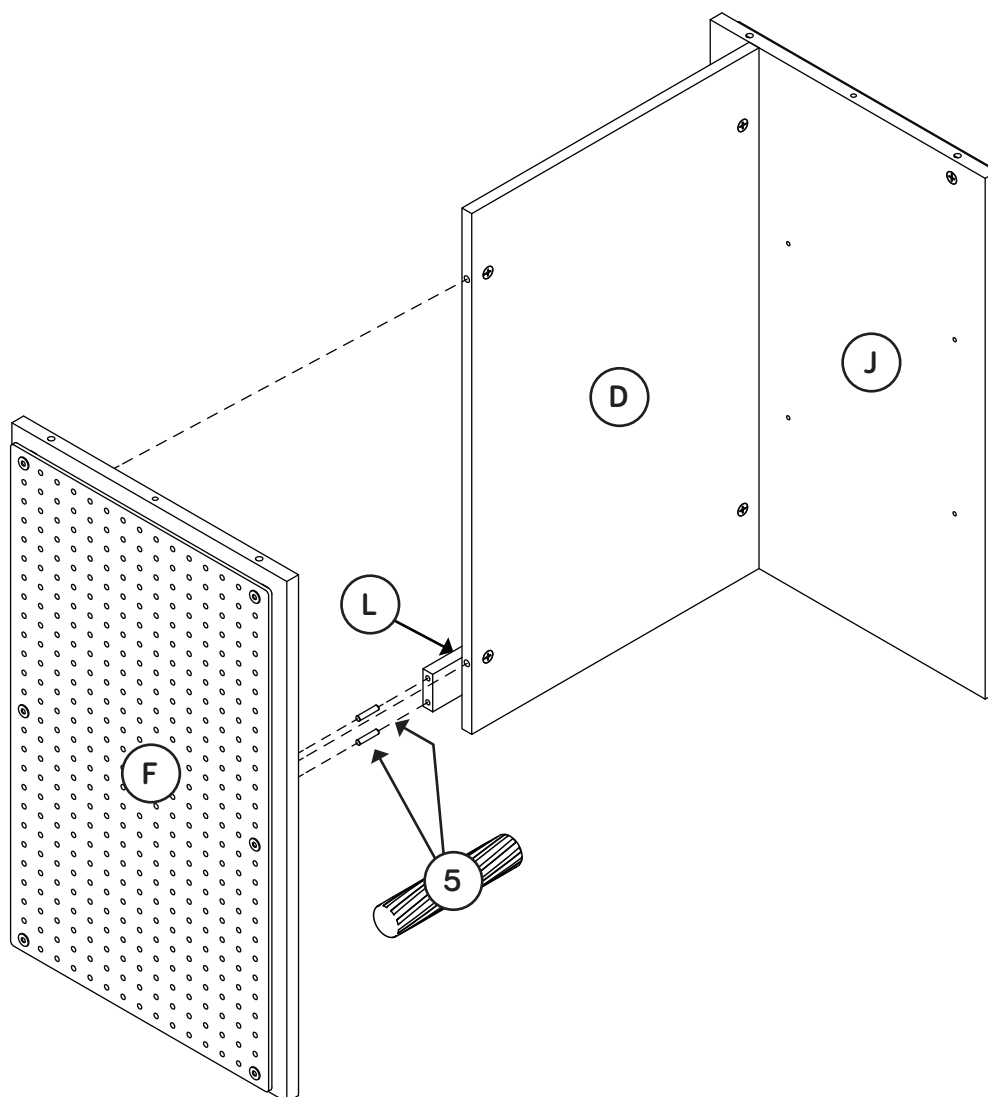
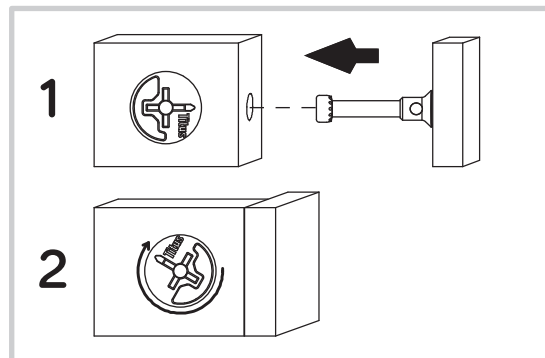

Step 7

- ✚ Insert a WOOD DOWEL (5) into the holes in each edge of the UPPER BACK (F) and CORK BOARD (J).
- ✚ Fasten the TOP (C) to the UPPER BACK (F) and CORK BOARD (J). Tighten four HIDDEN CAMS.
- ✚ **NOTE:** Be sure the WOOD DOWELS in the UPPER BACK and CORK BOARD insert into the holes in the TOP.

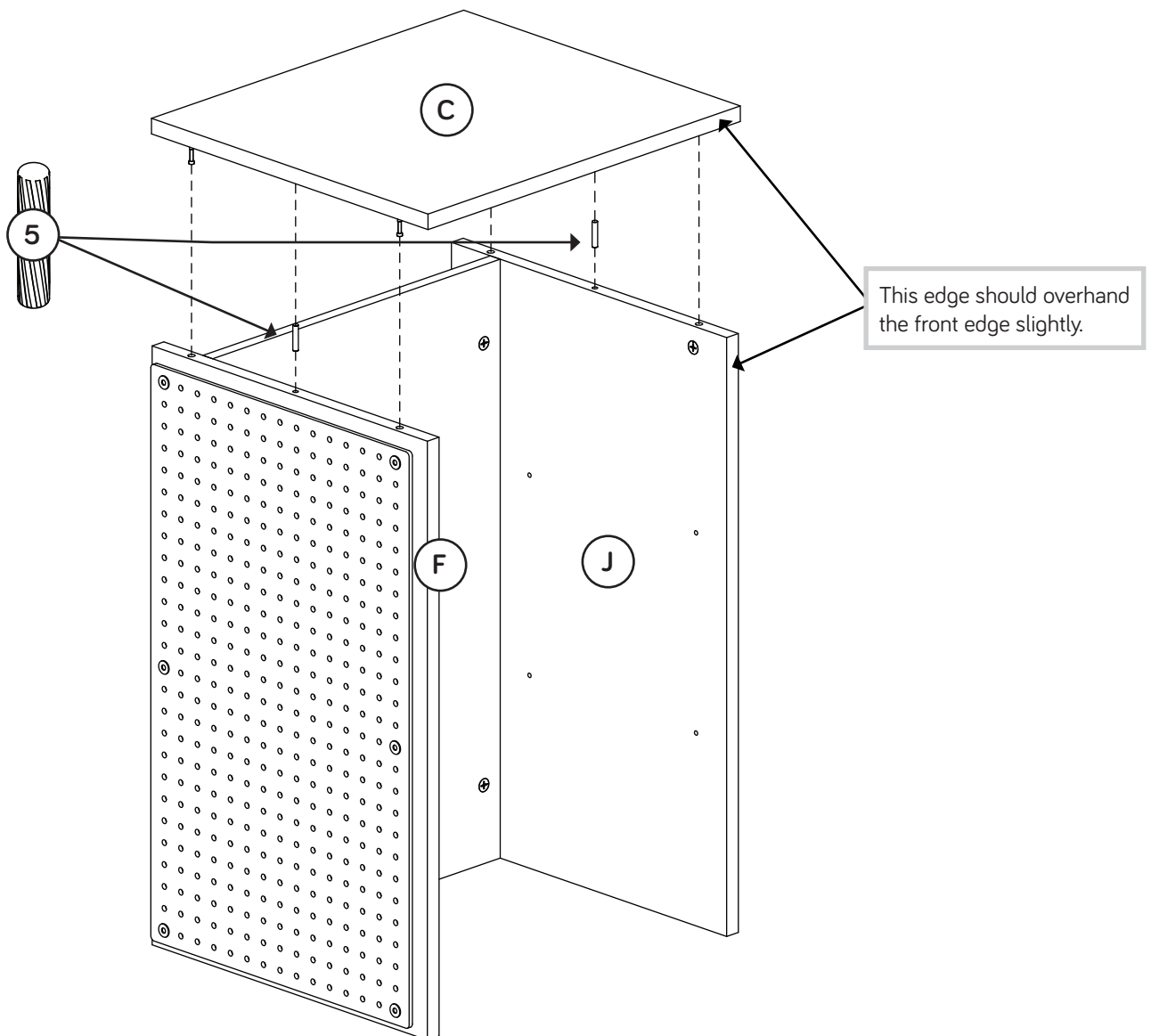
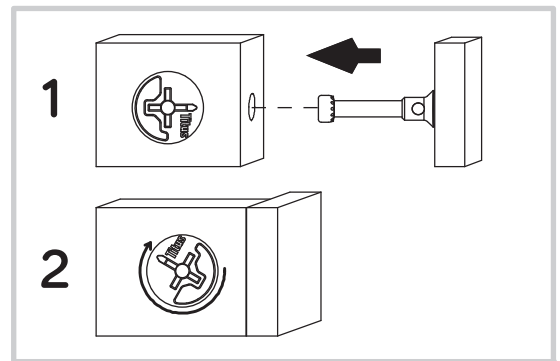

Step 8

✚ Carefully flip your unit over so the TOP (C) is on the floor.

✚ Insert a WOOD DOWEL (5) into each edge of the UPPER BACK (F) and CORK BOARD (J).

✚ Fasten the LOWER SHELF (H) to UPPER BACK (F) and CORK BOARD (J). Use four SILVER 1-3/16" FLAT HEAD SCREWS (14).

✚ **NOTE:** Be sure the WOOD DOWELS in the UPPER BACK and CORK BOARD insert into the holes in the LOWER SHELF.

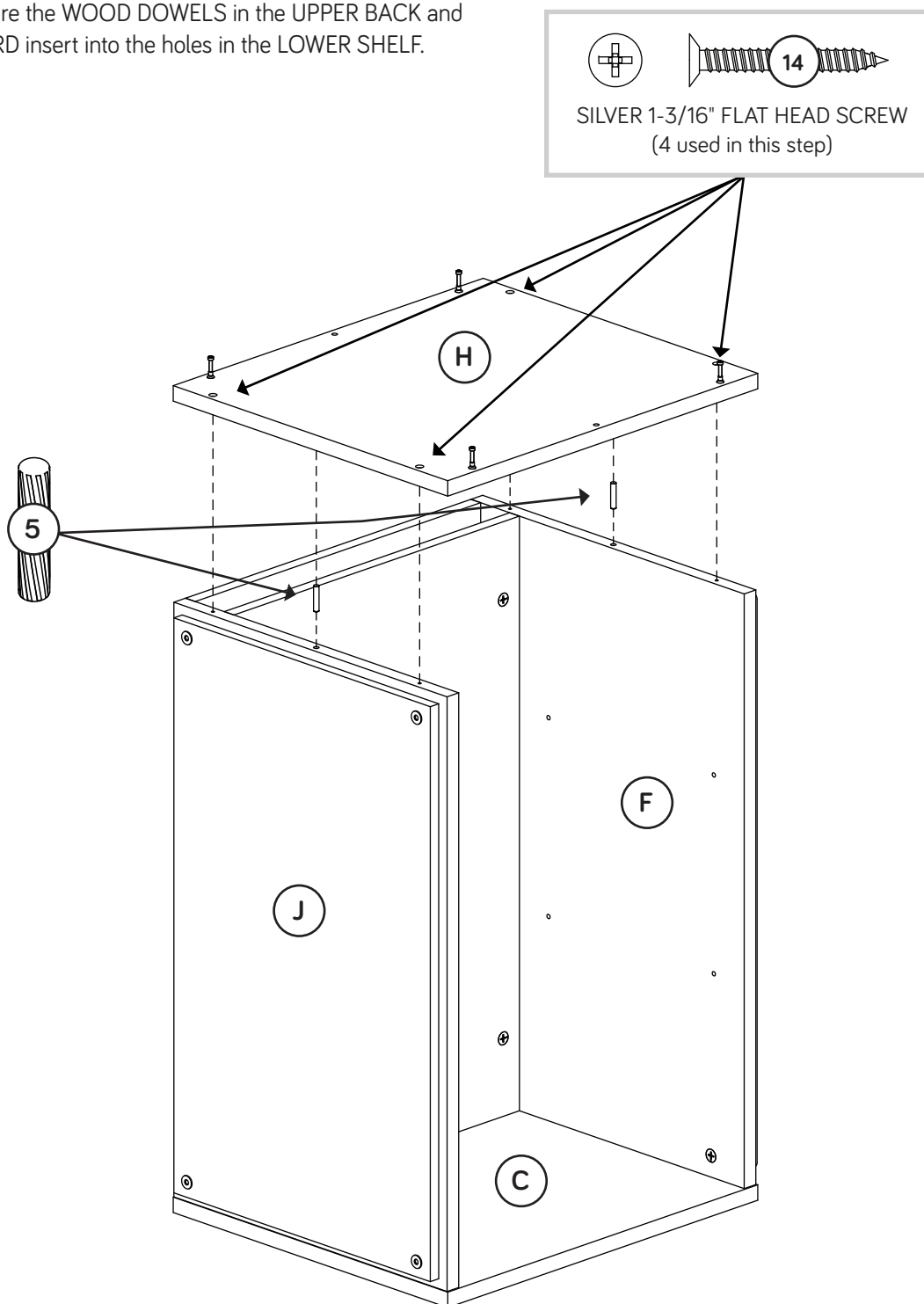

Step 9

- ✚ Separate the EXTENSION SLIDES (2) from the EXTENSION RAILS (1) as shown in the upper diagram below. Be prepared, the parts are greasy.
- ✚ Fasten the EXTENSION RAILS (1) to the LOWER ENDS (A and B). Use eight SILVER 1/2" FLAT HEAD SCREWS (18).
- ✚ **NOTE:** For each EXTENSION RAIL, turn a SCREW into the hole shown in the enlarged diagram. Then, slide the inner cartridge of the EXTENSION RAIL in to find the other hole that lines up with the hole in the ENDS. Turn a SCREW into this hole.
- ✚ **NOTE:** The EXTENSION SLIDES will be used later for the DRAWERS.

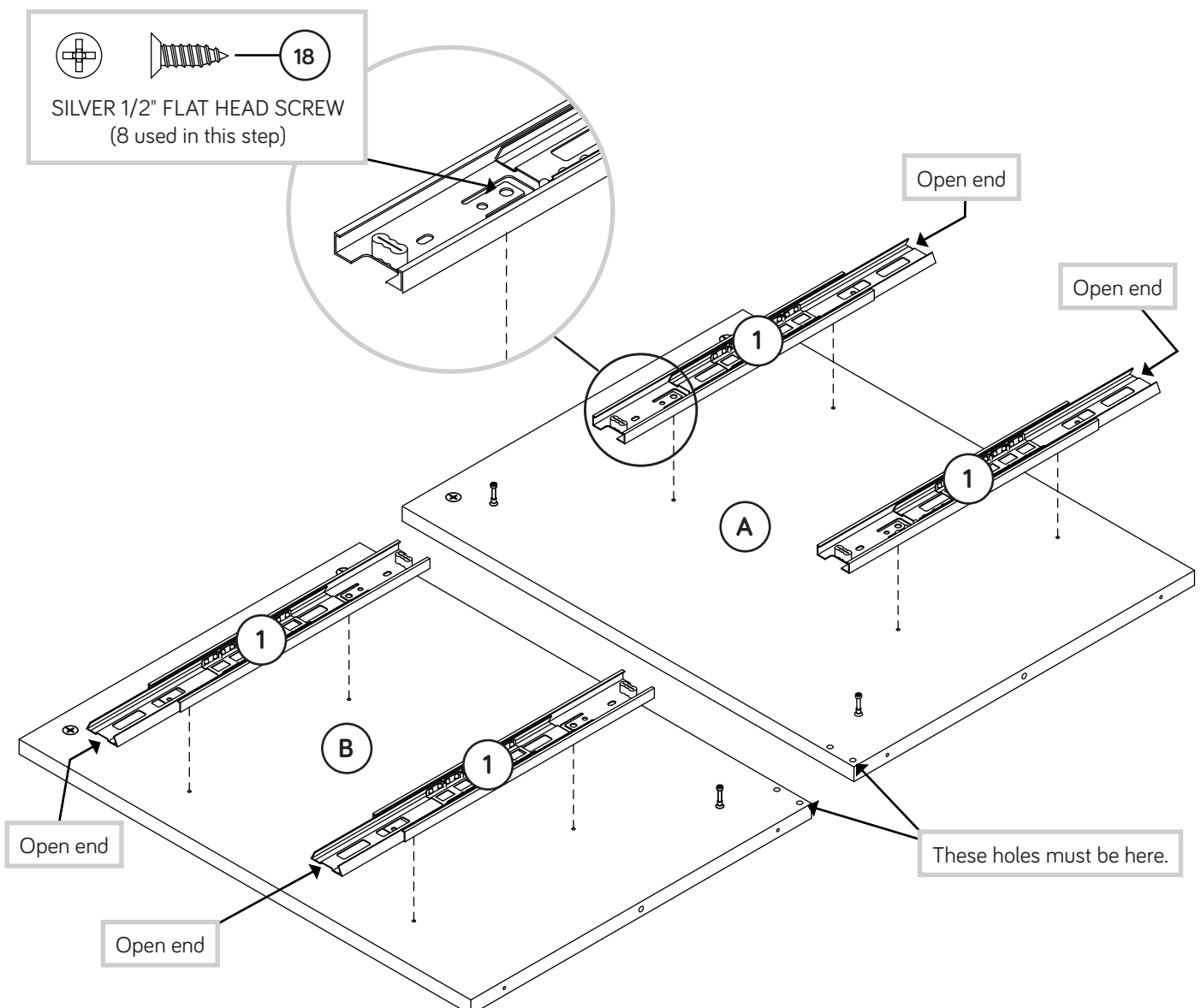
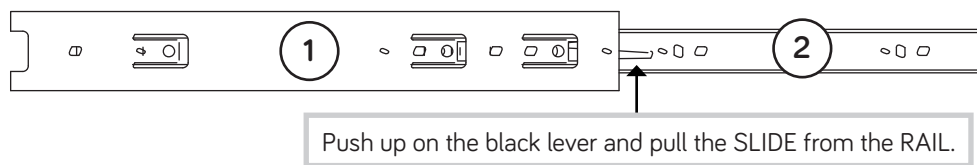

Step 10

✚ Insert two WOOD DOWELS (5) into the LOWER RIGHT END (A). Fasten the LOWER BRACE (K) to the LOWER RIGHT END (A) by pushing the LOWER BRACE (K) onto the WOOD DOWELS.

✚ Fasten the LOWER BACK (I) to the LOWER RIGHT END (A). Tighten two HIDDEN CAMS.

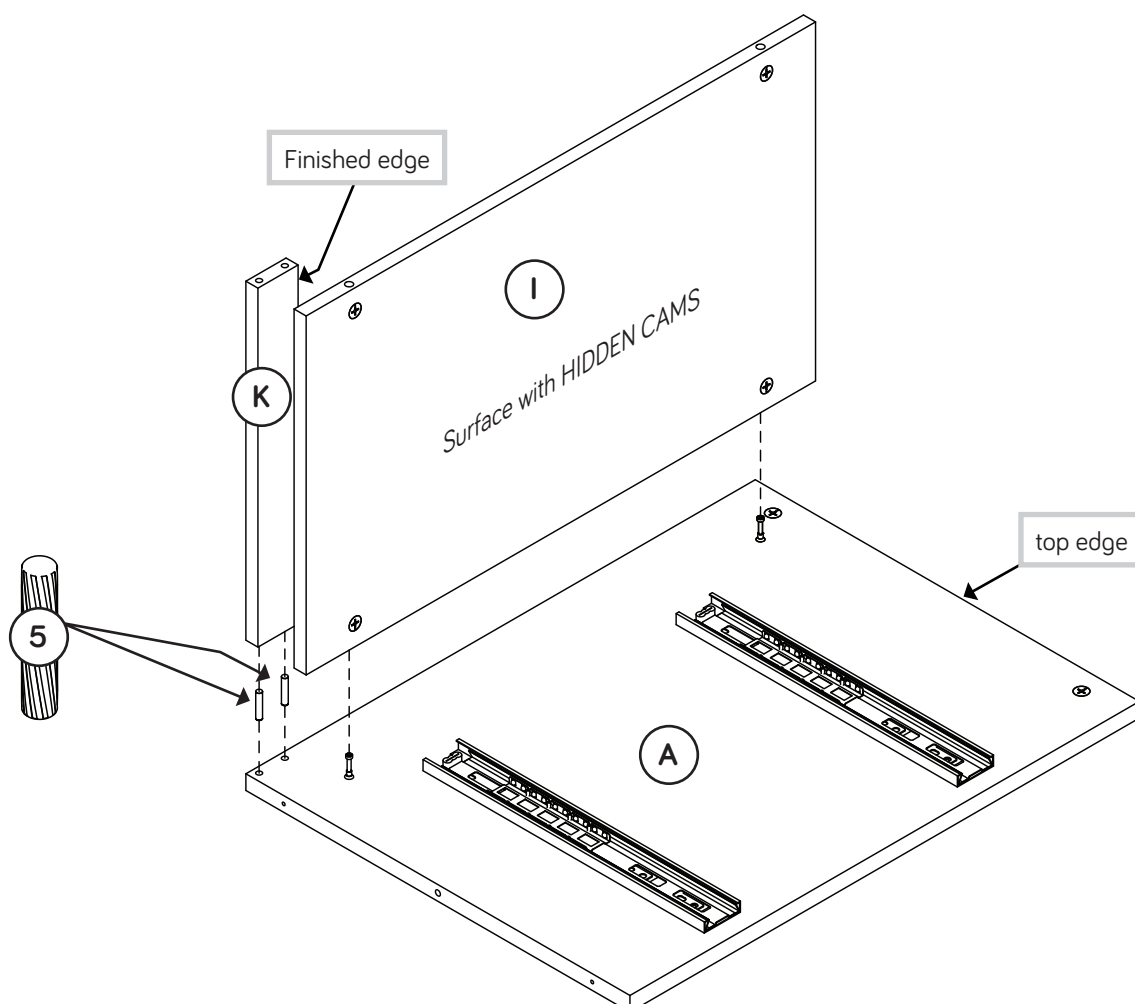
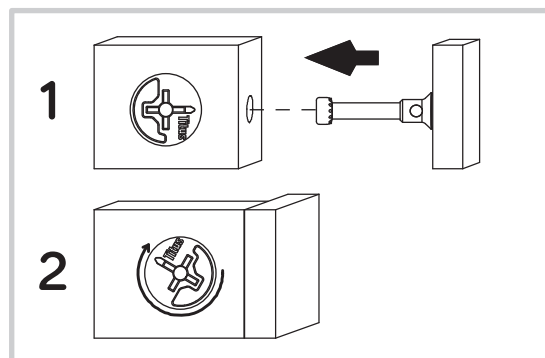

Step 11

- ✚ Turn your unit onto its top edges while keeping the LOWER BRACE (K) in place.
- ✚ Insert two WOOD DOWELS (5) into the LOWER BRACE (K).
- ✚ Fasten the LOWER LEFT END (B) to the LOWER BACK (I). Tighten two HIDDEN CAMS.
- ✚ **NOTE:** Be sure the WOOD DOWELS in the LOWER BRACE insert into the holes in the LOWER LEFT END.

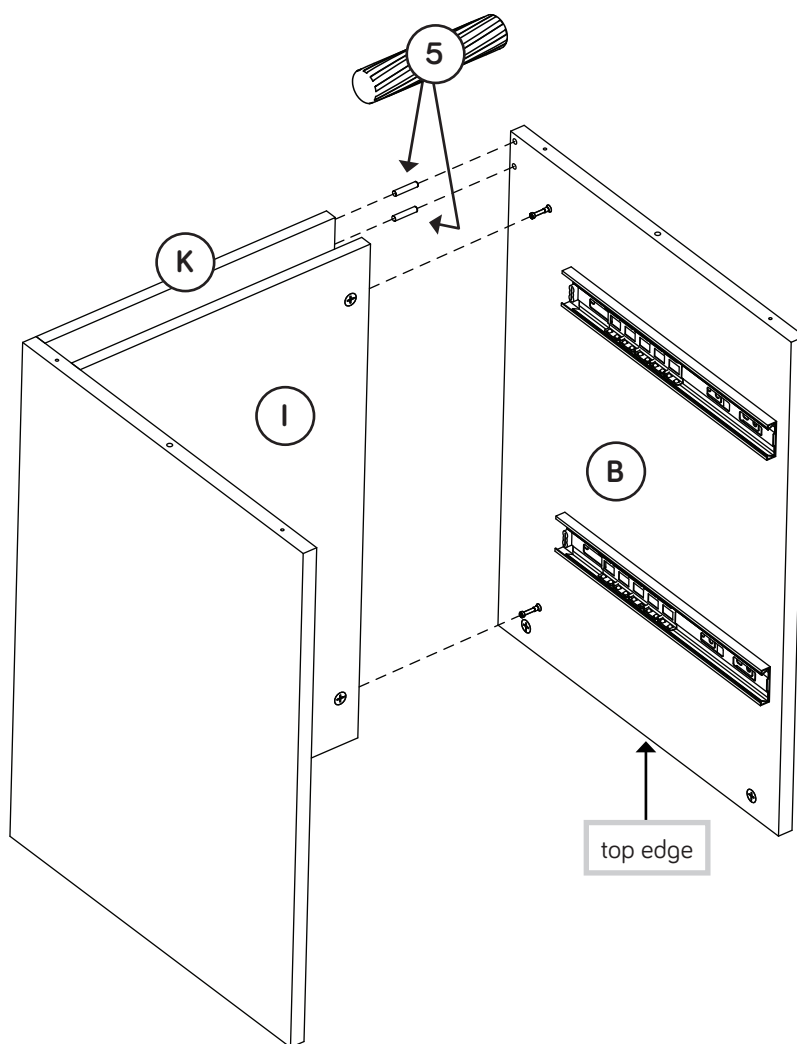

Step 12

- ✚ Insert a WOOD DOWEL (5) into each edge of the LOWER ENDS (A and B).
- ✚ Fasten the BOTTOM (M) to the LOWER ENDS (A and B). Use four SILVER 1-3/16" FLAT HEAD SCREWS (14).
- ✚ **NOTE:** Be sure the WOOD DOWELS in the LOWER ENDS insert into the holes in the BOTTOM.

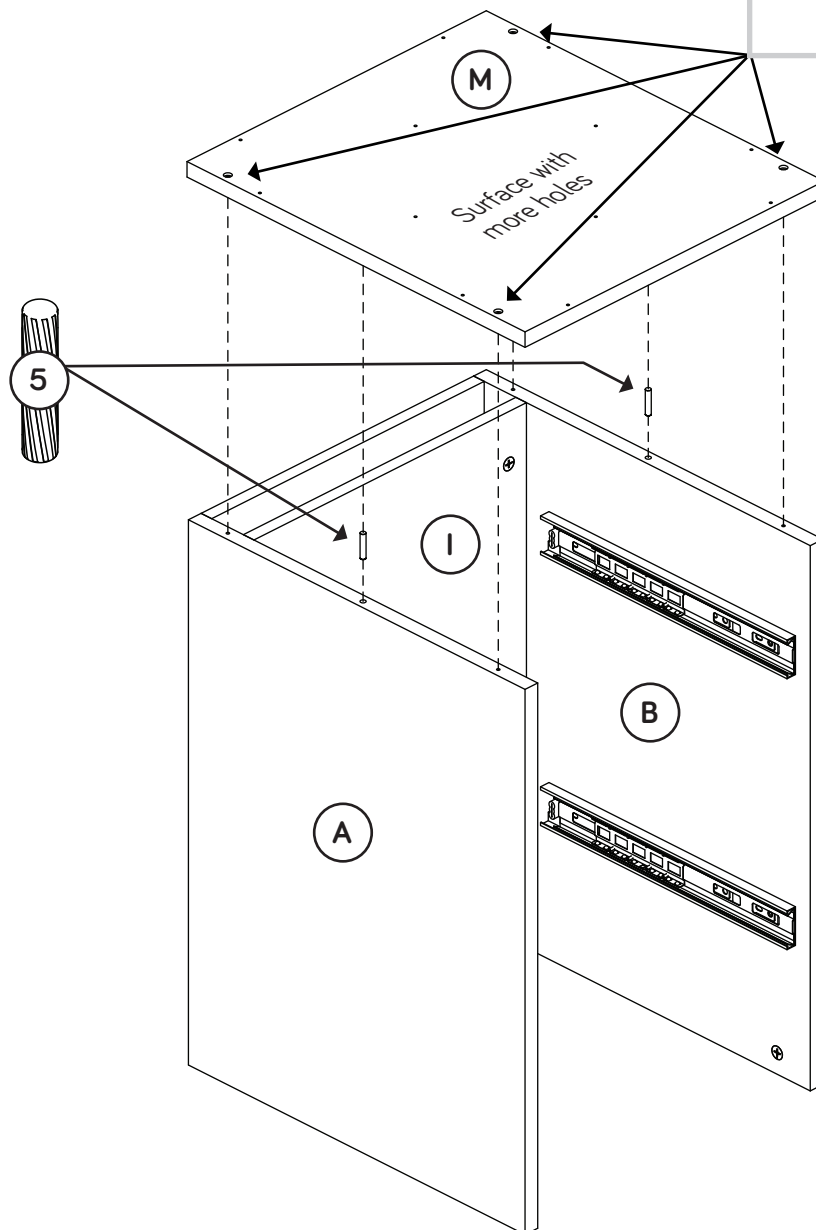
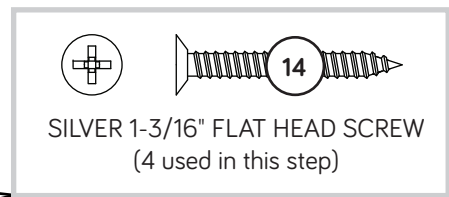

Step 13

- Fasten eight METAL BRACKETS (9) to the BASE MOLDINGS (P and Q). Use eight SILVER 1/2" PAN HEAD SCREWS (17).

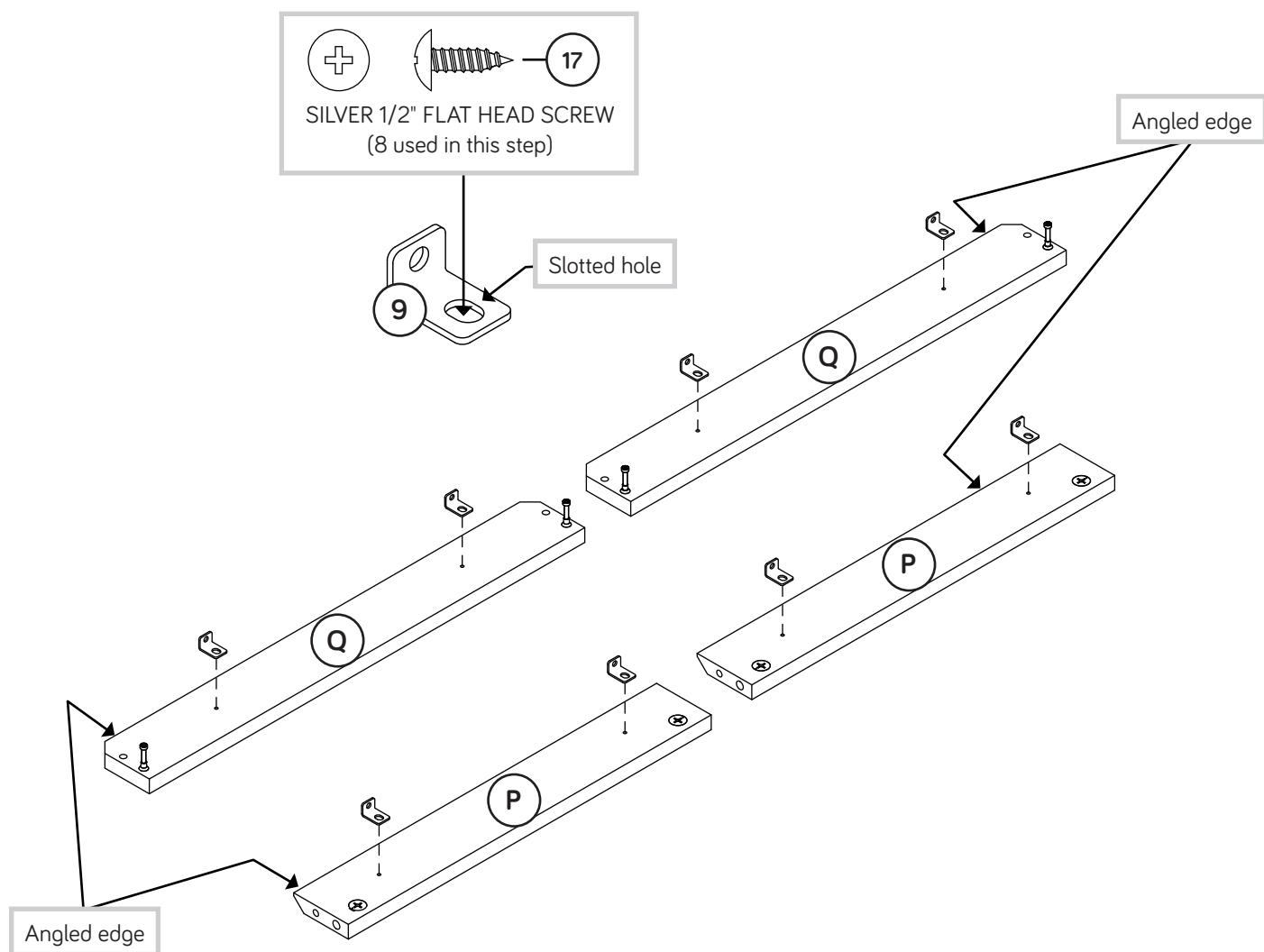

Step 14

- ✚ Insert four WOOD DOWELS (5) into the LONG BASE MOLDINGS (Q).
- ✚ Fasten the SHORT BASE MOLDINGS (P) to the LONG BASE MOLDINGS (Q). Tighten four HIDDEN CAMS.
- ✚ **NOTE:** Be sure the WOOD DOWELS in the LONG BASE MOLDING insert into the holes in the SHORT BASE MOLDINGS.

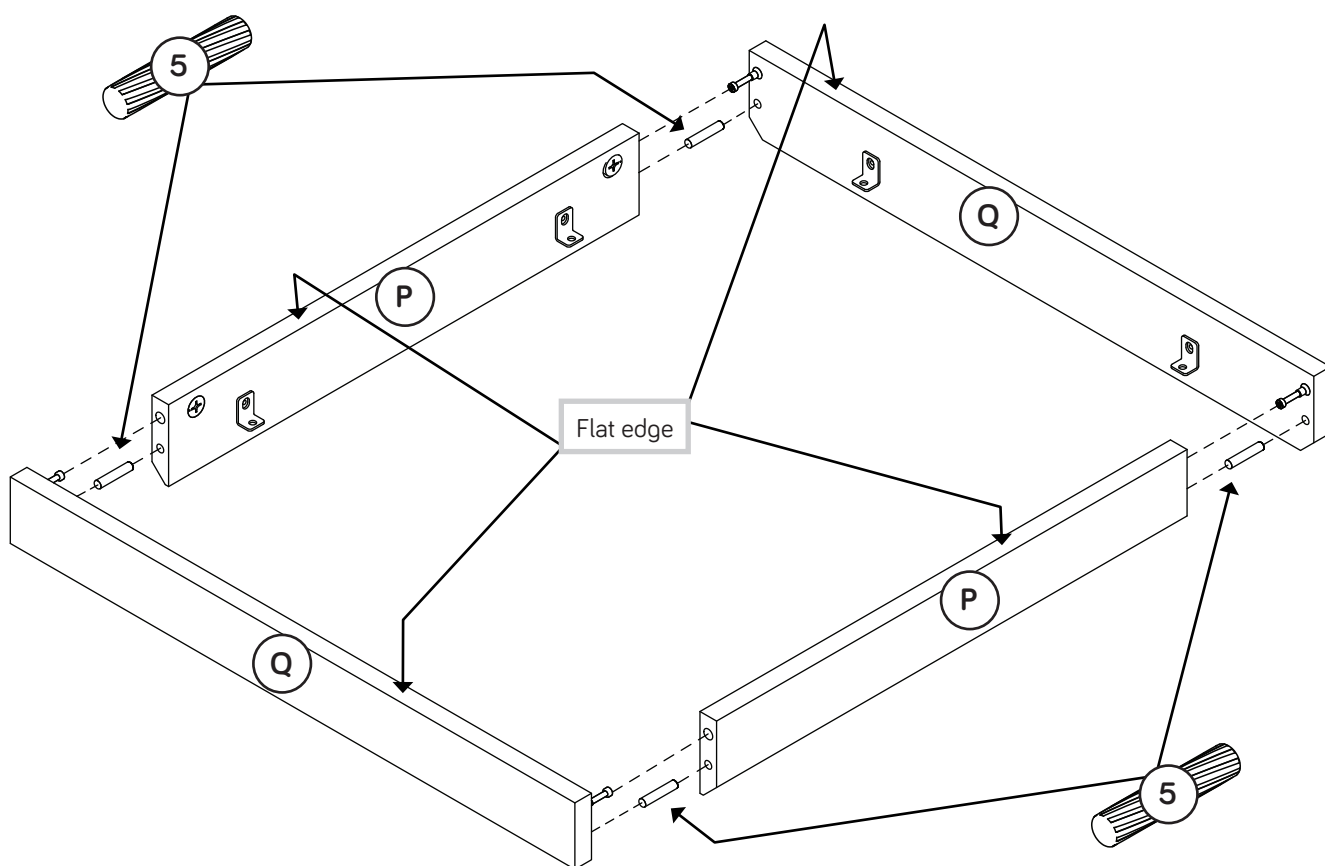
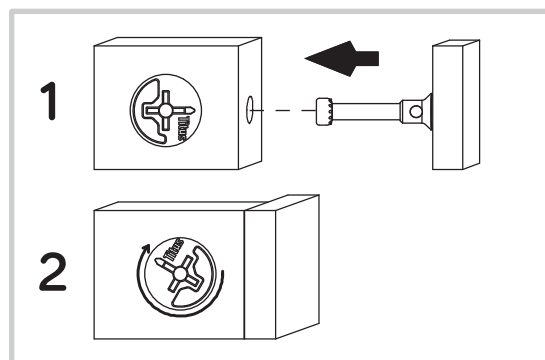

Step 15

Fasten the BASE MOLDINGS (P and Q) to the BOTTOM (M).
Use eight SILVER 1/2" PAN HEAD SCREWS (17).

NOTE: You may need to loosen the screws in the METAL BRACKETS so the BASE MOLDINGS (P and Q) cover the BOTTOM (M) edges.

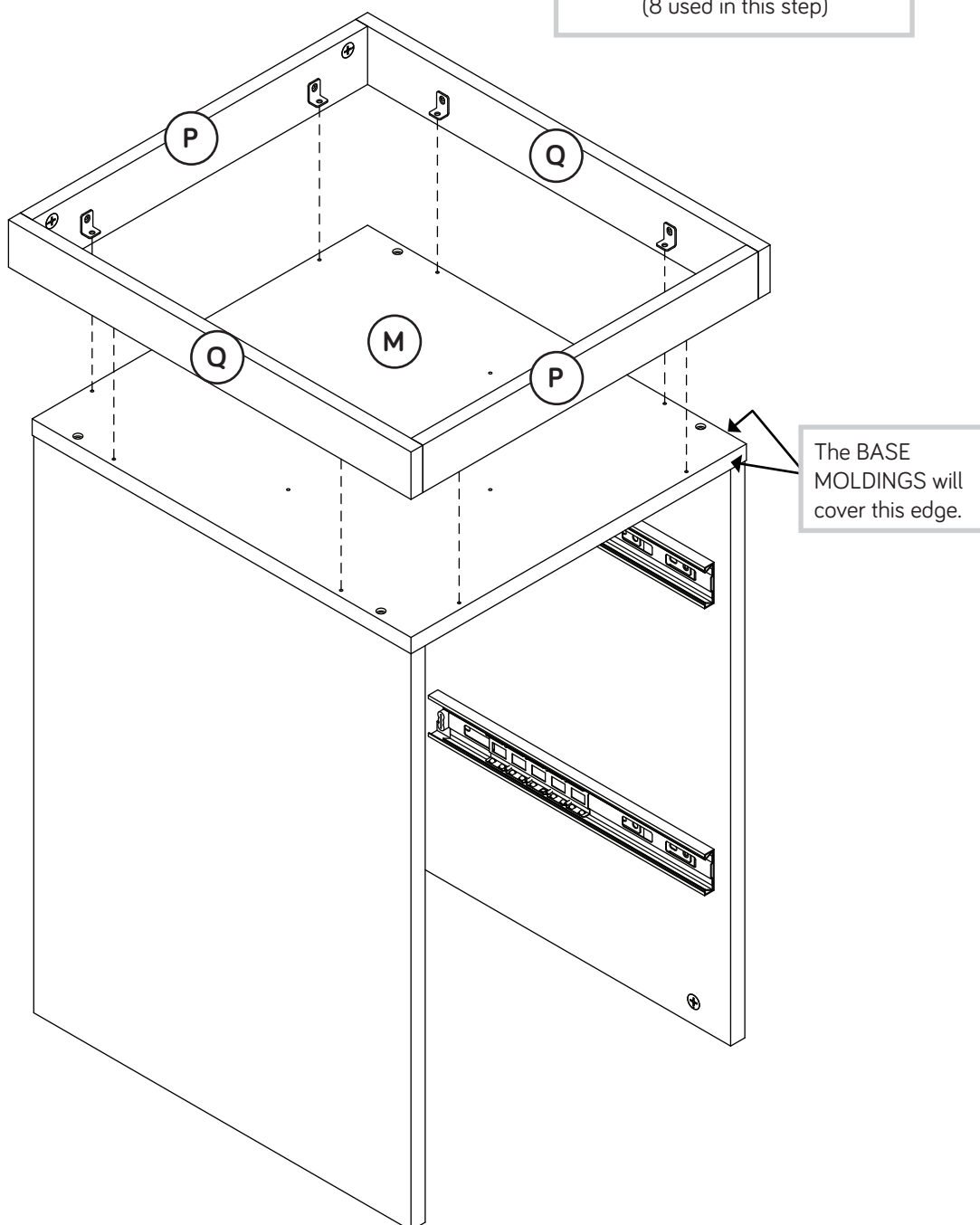
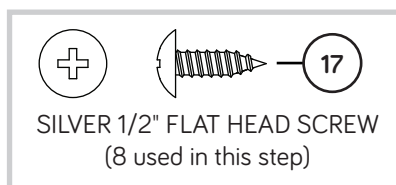

Step 16

- Fasten the TURNTABLE (12) to the TURNTABLE BOTTOM (N).
Use four SILVER 1/2" PAN HEAD SCREWS (17).



Just breathe.
It's going to be ok.

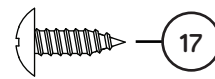

17

SILVER 1/2" FLAT HEAD SCREW
(4 used in this step)

The large hole in the
TURNTABLE (12) must
line up with the large
hole in the TURNTABLE
BOTTOM (N).

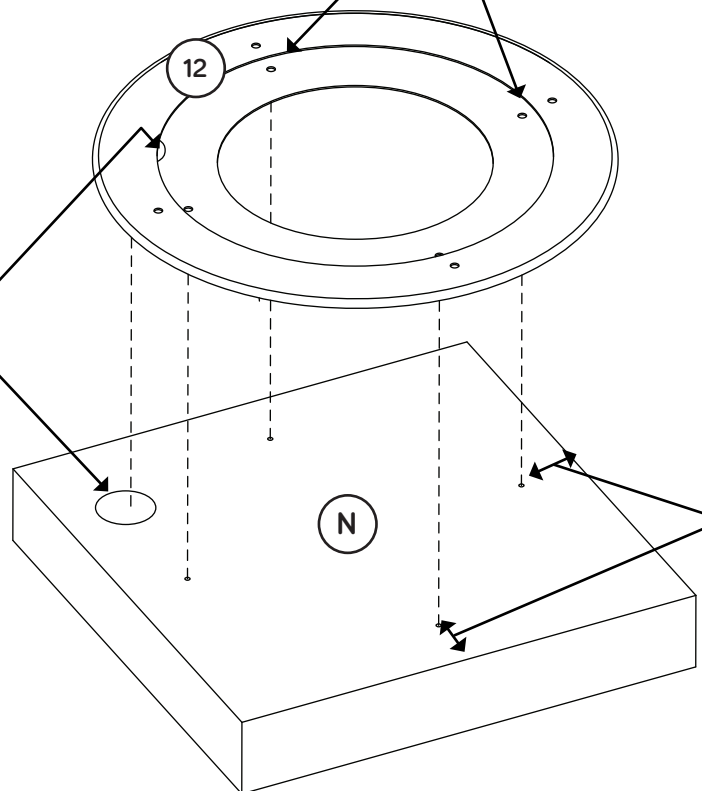

The holes must be
1-5/8" from the edges.

Step 17

- ✚ Flip the TURNTABLE (12) and TURNTABLE BOTTOM (N) over.
- ✚ Place the TURNTABLE (12) on the BOTTOM (M), so the large hole in the TURNTABLE BOTTOM (N) lines up with the hole in the TURNTABLE and the hole in the BOTTOM as shown below in diagram 1. Fasten the TURNTABLE to the BOTTOM with a SILVER 1/2" FLAT HEAD SCREW (17).
- ✚ Turn the TURNTABLE BOTTOM (N) counterclockwise 90 degrees to find the next hole as shown below in diagram 2. Turn a SILVER 1/2" FLAT HEAD SCREW (17) into this hole.
- ✚ Turn the TURNTABLE BOTTOM (N) counterclockwise 90 degrees to find the next hole as shown below in diagram 3. Turn a SILVER 1/2" FLAT HEAD SCREW (17) into this hole.
- ✚ Turn the TURNTABLE BOTTOM (N) counterclockwise 90 degrees to find the next hole as shown below in diagram 4. Turn a SILVER 1/2" FLAT HEAD SCREW (17) into this hole.

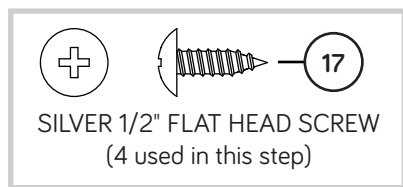

IMPORTANT: Turn all screws in a few turns before completely tightening any of them.

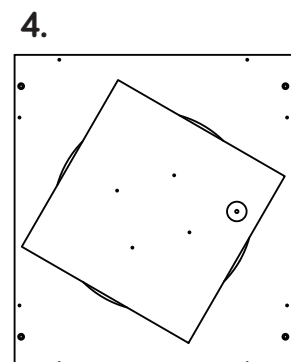
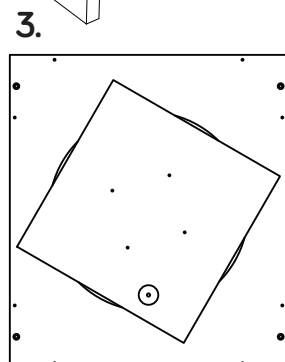
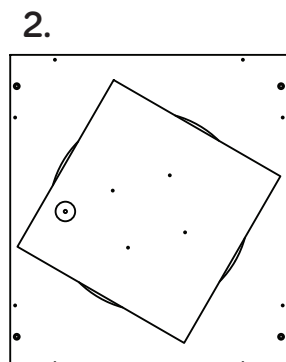
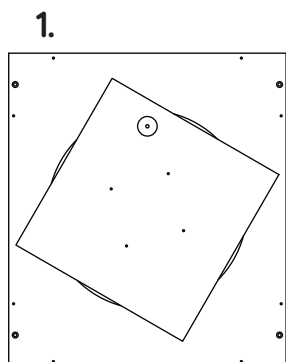
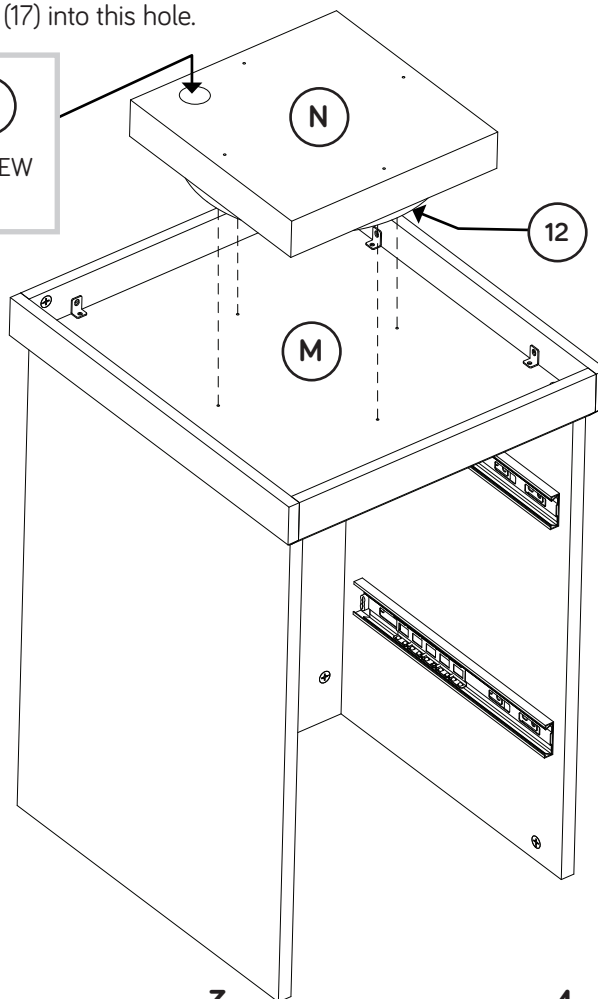

Step 18

- Fasten the BASE (O) to the TURNTABLE BOTTOM (N).
Use four SILVER 1-7/8" FLAT HEAD SCREWS (13).

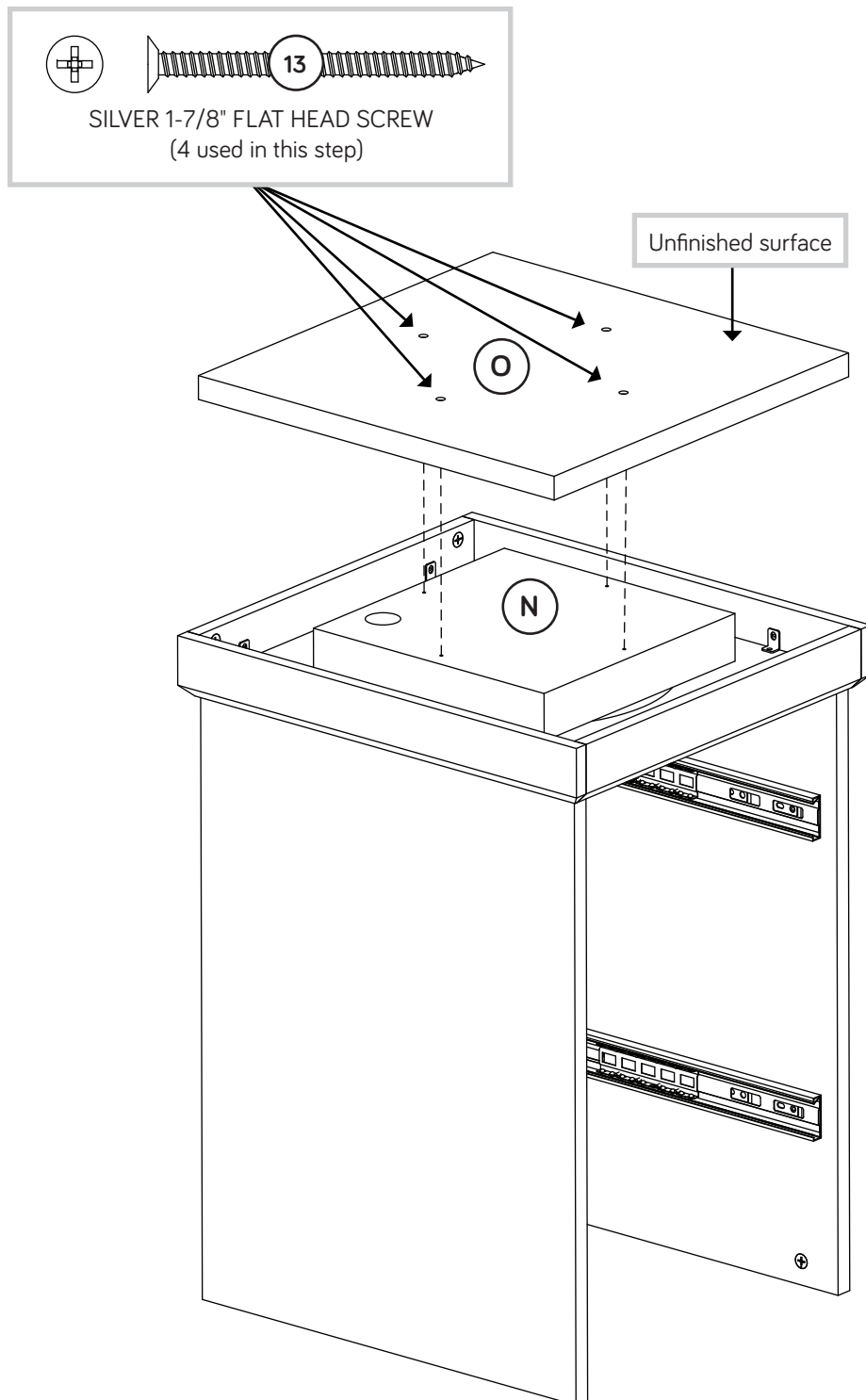

Step 19

- ✚ Carefully stand your unit upright on the BASE (O).
- ✚ Insert a WOOD DOWEL (5) into the hole in the edge of each LOWER END (A and B).
- ✚ Fasten the LOWER SHELF (H) to the LOWER ENDS (A and B). Tighten four HIDDEN CAMS.
- ✚ **NOTE:** Be sure the WOOD DOWELS in the LOWER ENDS insert into the holes in the LOWER SHELF.

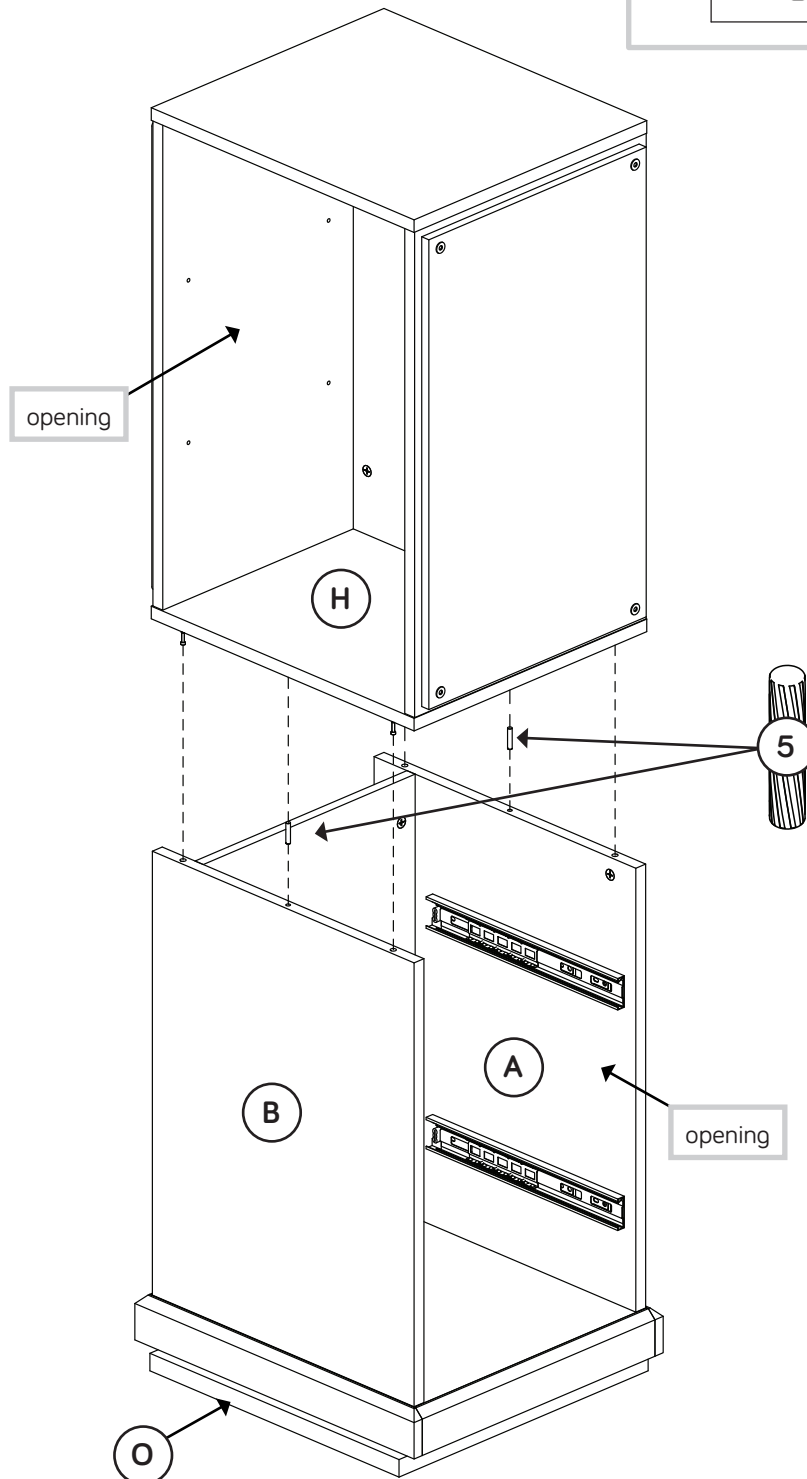
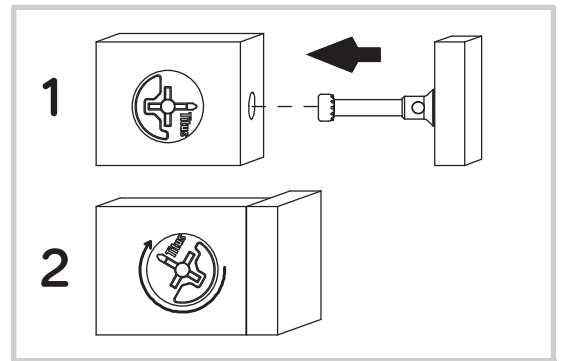

Step 20

1



SILVER 1-3/16" FLAT HEAD SCREW
(8 used in this step)

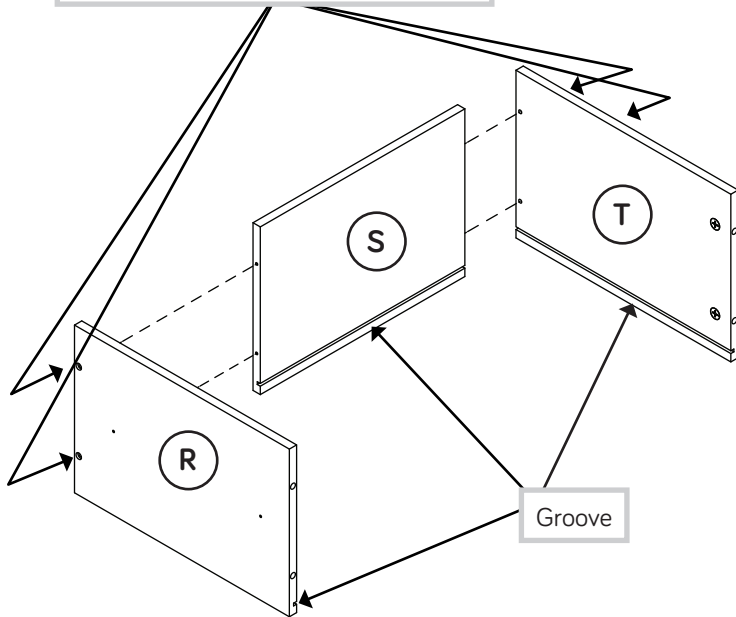

Fasten the DRAWER SIDES (R and T) to the DRAWER BACK (S).
Use four SILVER 1-3/16" FLAT HEAD SCREWS (14).

2

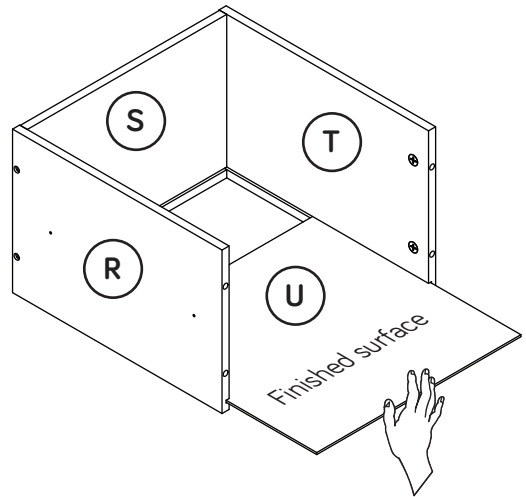

Slide a DRAWER BOTTOM (U) into the grooves
in the DRAWER SIDES (R and T) and DRAWER
BACK (S).

3

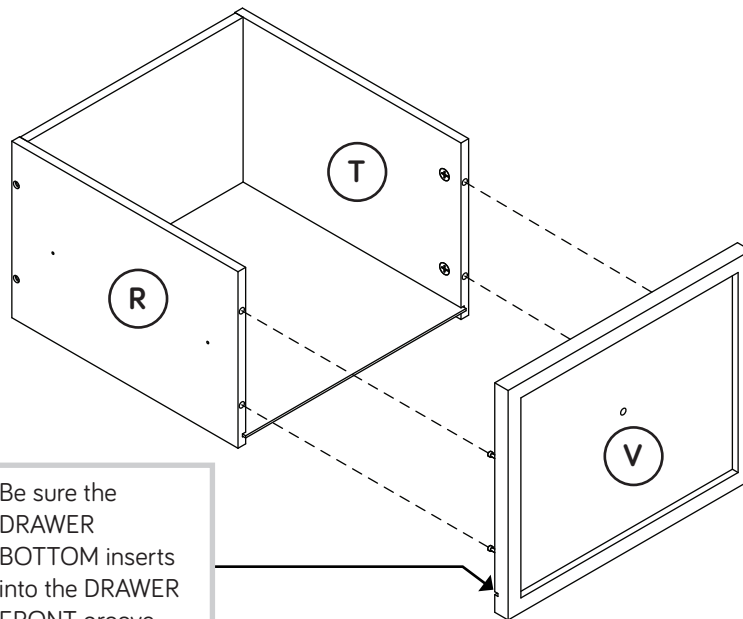

Fasten the DRAWER FRONT (V) to the DRAWER SIDES (R and T). Tighten four HIDDEN CAMS.

NOTE: Be sure the DRAWER BOTTOM inserts into the groove of the DRAWER FRONT.

Repeat this step for the other drawer.

Step 21

- Fasten two EXTENSION SLIDES (2) to the DRAWER SIDES (R and T). Use four SILVER 1/2" FLAT HEAD SCREWS (18).
- Fasten the KNOB (6) to the DRAWER FRONT (V). Use a SILVER 11/16" MACHINE SCREW (19).
- Repeat this step for the other drawer.

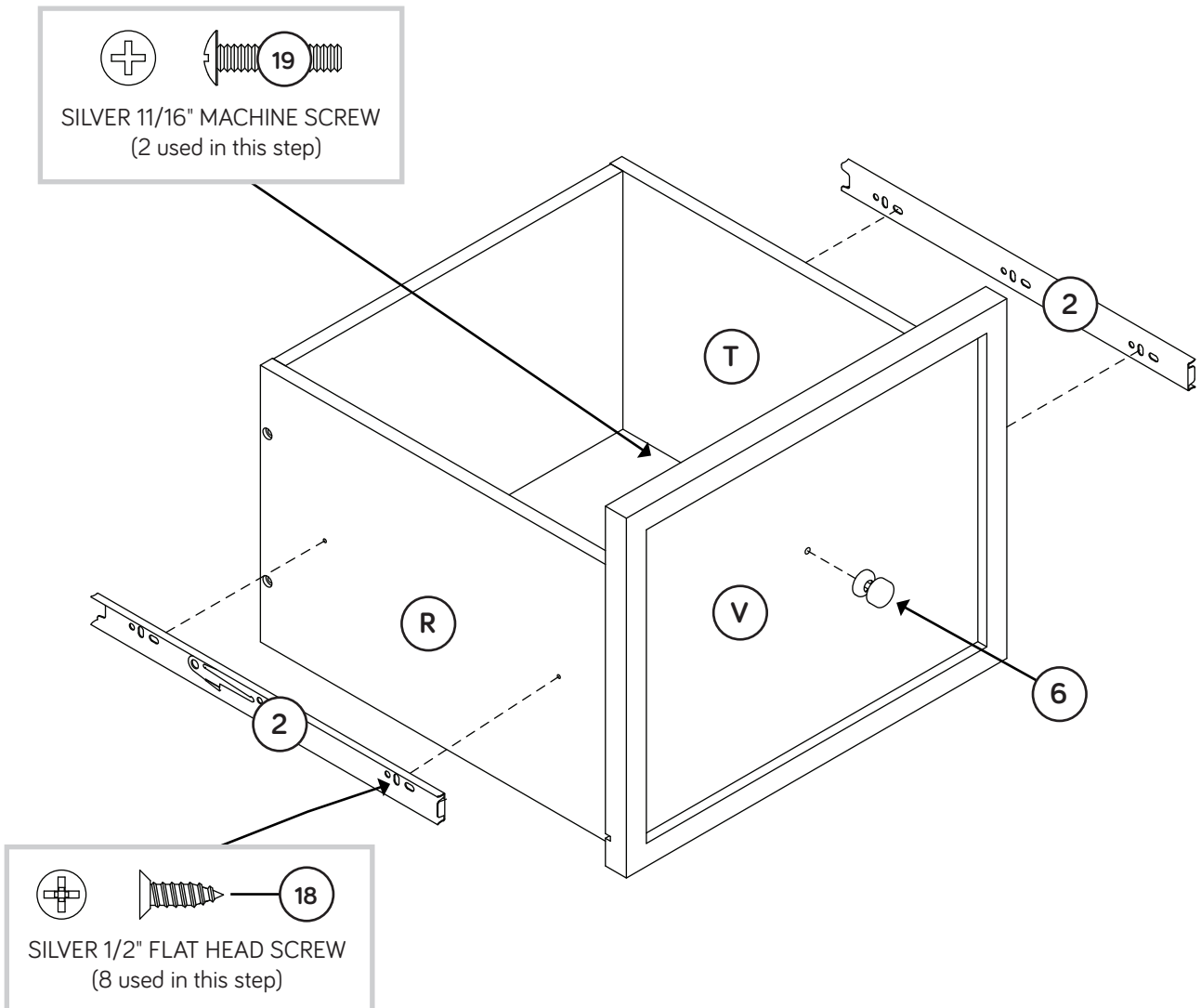
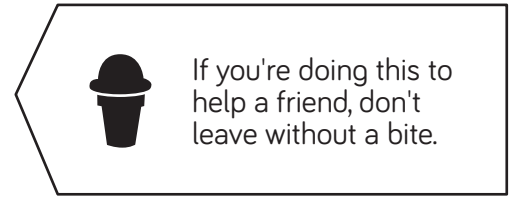

Step 22

- Fasten the LONG METAL SHELVES (X) to the UPPER RIGHT END (D). Use nine SILVER 1/2" PAN HEAD SCREWS (17).
- Fasten the SHORT METAL SHELVES (W) to the LOWER BACK (I). Use nine SILVER 1/2" PAN HEAD SCREWS (17).

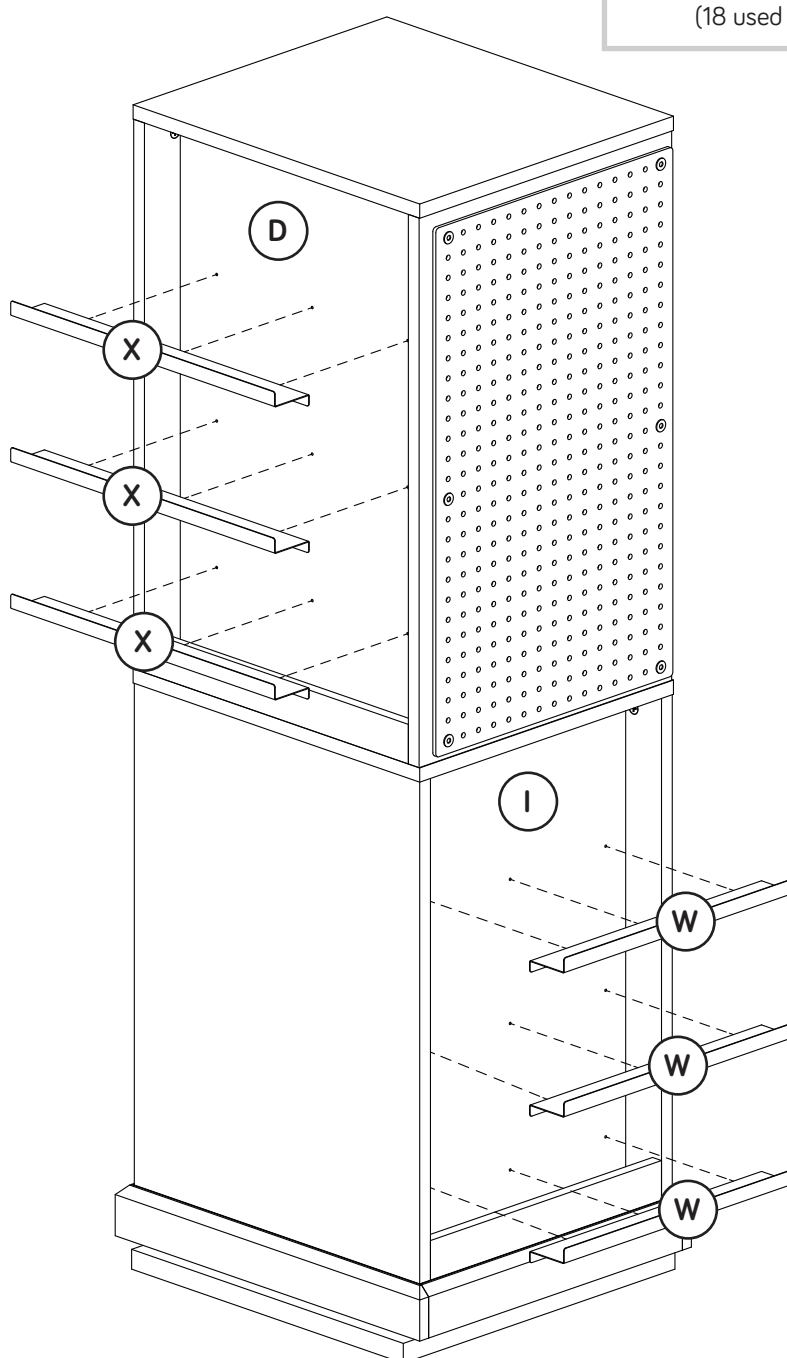
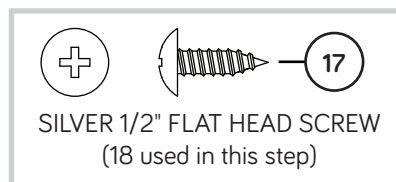

Step 23

- ✚ Push eight METAL PINS (8) into the UPPER BACK (F) and CORK BOARD (J).
- ✚ Set the SHELVES (G) onto the METAL PINS (8).
- ✚ To insert the drawers into your unit, line up the EXTENSION SLIDES on the drawers with the EXTENSION RAILS on the unit and push the drawers into the unit until they are fully inserted. The drawers will push in hard until they are all the way in, then they will slide in and out easier.

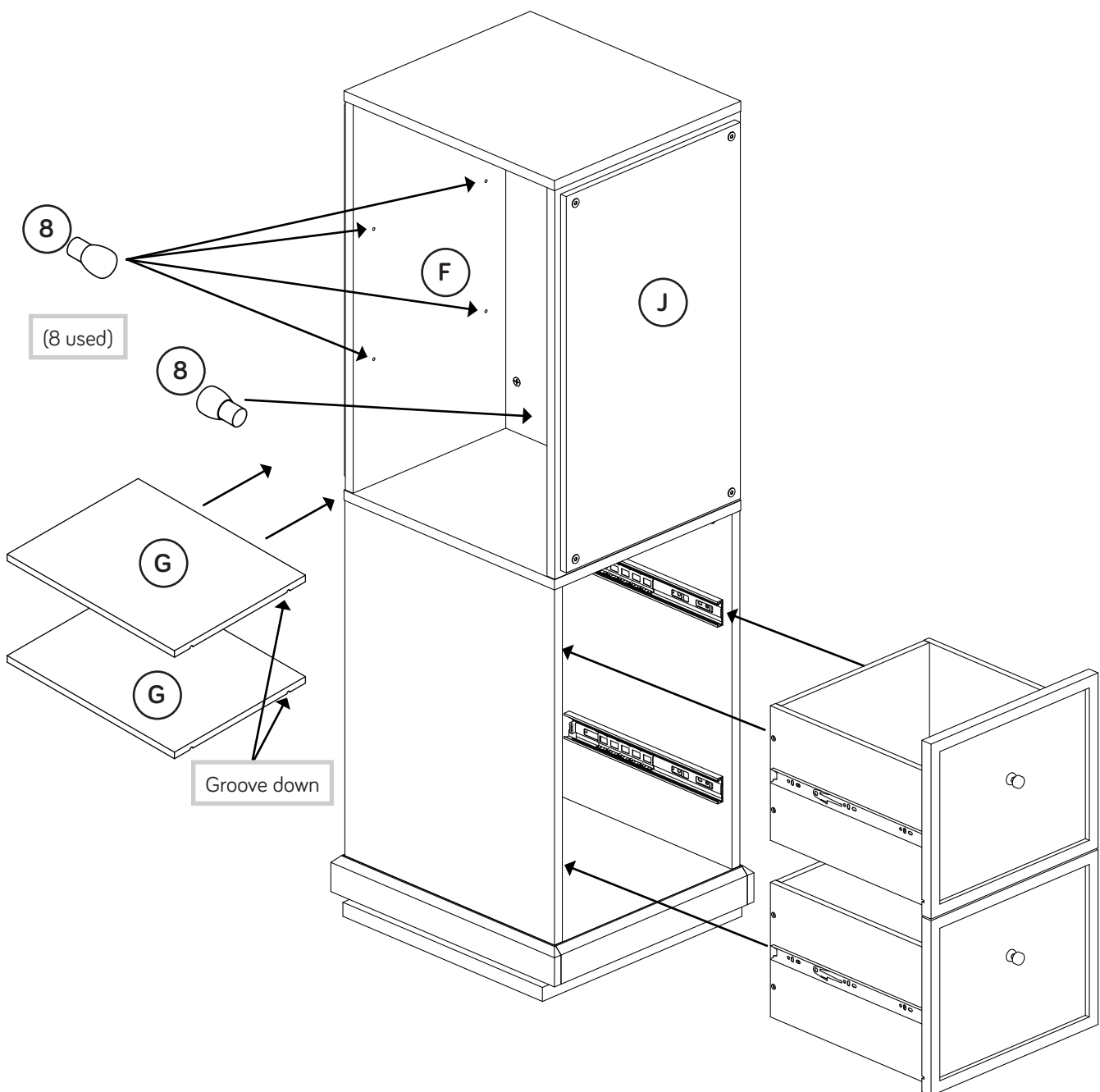

Step 24

- ✚ Peel a CAM COVER from the CAM COVER CARD (7) and stick one onto each visible HIDDEN CAM.
- ✚ **NOTE:** Please read the back pages of the instruction booklet for important safety information.
- ✚ This completes assembly. Clean with your favorite furniture polish or a damp cloth. Wipe dry.

